

## WARNING

THE FOLLOWING SERVICING INSTRUCTIONS ARE FOR USE BY QUALIFIED PERSONNEL ONLY. TO AVOID PERSONAL INJURY, DO NOT PERFORM ANY SERVICING UNLESS YOU ARE QUALIFIED TO DO SO.

**PLEASE CHECK FOR CHANGE INFORMATION  
AT THE REAR OF THIS MANUAL.**

# 2215 OSCILLOSCOPE SERVICE

## INSTRUCTION MANUAL

Tektronix, Inc.  
P.O. Box 500  
Beaverton, Oregon 97077

070-3826-00  
Product Group 46

Serial Number \_\_\_\_\_

First Printing JUL 1981  
Revised NOV 1981

Copyright © 1981 Tektronix, Inc. All rights reserved.  
Contents of this publication may not be reproduced in  
any form without the written permission of Tektronix, Inc.

Products of Tektronix, Inc. and its subsidiaries are  
covered by U.S. and foreign patents and/or pending  
patents.

TEKTRONIX, TEK, SCOPE-MOBILE, and  are  
registered trademarks of Tektronix, Inc. TELEQUIP-  
MENT is a registered trademark of Tektronix, U.K.  
Limited.

Printed in U.S.A. Specification and price change  
privileges are reserved.

# TABLE OF CONTENTS

	Page		Page
LIST OF ILLUSTRATIONS . . . . .	iv	<b>SECTION 3 THEORY OF OPERATION</b>	
LIST OF TABLES . . . . .	v	INTRODUCTION . . . . .	3-1
OPERATORS SAFETY SUMMARY . . . . .	vi	GENERAL DESCRIPTION . . . . .	3-2
SERVICING SAFETY SUMMARY . . . . .	vii	DETAILED CIRCUIT	
		DESCRIPTION . . . . .	3-4
<b>SECTION 1 SPECIFICATION</b>		VERTICAL ATTENUATORS . . . . .	3-4
INTRODUCTION . . . . .	1-1	Input Coupling . . . . .	3-4
ACCESSORIES . . . . .	1-1	High-Z Attenuator . . . . .	3-5
PERFORMANCE CONDITIONS . . . . .	1-1	Buffer Amplifier and Low-Z	
		Attenuator . . . . .	3-5
		Volts/Div Var Circuit and	
		X1/X10 Amplifier . . . . .	3-6
<b>SECTION 2 OPERATING INSTRUCTIONS</b>		VERTICAL PREAMPS . . . . .	3-6
PREPARATION FOR USE . . . . .	2-1	Channel 1 Vertical Preamplifier . . . . .	3-6
SAFETY . . . . .	2-1	Channel 2 Vertical Preamplifier . . . . .	3-7
LINE VOLTAGE . . . . .	2-1	Internal Trigger Pickoff	
POWER CORD . . . . .	2-1	Amplifier . . . . .	3-7
LINE FUSE . . . . .	2-1	CHANNEL SWITCH AND	
CONTROLS, CONNECTORS,		VERTICAL OUTPUT . . . . .	3-7
AND INDICATORS . . . . .	2-3	Diode Gates . . . . .	3-7
POWER, DISPLAY, AND		Delay Line Driver . . . . .	3-9
PROBE ADJUST . . . . .	2-3	Delay Line . . . . .	3-9
VERTICAL . . . . .	2-3	Vertical Output Amplifier . . . . .	3-9
HORIZONTAL . . . . .	2-5	A/B Sweep Separation Circuit . . . . .	3-9
TRIGGER . . . . .	2-6	Channel Switching Logic	
REAR PANEL . . . . .	2-8	Circuit . . . . .	3-9
OPERATING CONSIDERATIONS . . . . .	2-9	Internal Trigger Switching	
GRATICULE . . . . .	2-9	Logic . . . . .	3-10
GROUNDING . . . . .	2-9	TRIGGER . . . . .	3-13
SIGNAL CONNECTIONS . . . . .	2-9	Internal Trigger Amplifier . . . . .	3-13
INPUT COUPLING CAPACITOR		Trigger Source-Switching	
PRECHARGING . . . . .	2-9	Circuit . . . . .	3-13
INSTRUMENT COOLING . . . . .	2-10	A External Trigger Amplifier . . . . .	3-13
OSCILLOSCOPE DISPLAYS . . . . .	2-10	Auto Trigger Circuit . . . . .	3-13
INTRODUCTION . . . . .	2-10	Trigger Level Comparator . . . . .	3-14
BASELINE TRACE . . . . .	2-10	Inverting Amplifier and	
SIGNAL DISPLAY . . . . .	2-10	TV Trigger Circuit . . . . .	3-14
MAGNIFIED-SWEEP DISPLAY . . . . .	2-11	Schmitt Trigger Circuit . . . . .	3-15
DELAYED-SWEEP DISPLAY . . . . .	2-11	Auto Baseline Circuit . . . . .	3-15
DELAYED-SWEEP		A SWEEP GENERATOR AND	
MEASUREMENTS . . . . .	2-11	LOGIC . . . . .	3-16
X-Y DISPLAY . . . . .	2-12	Miller Sweep Generator . . . . .	3-16
		Sweep Logic . . . . .	3-17

# TABLE OF CONTENTS (cont)

	Page		Page
<b>SECTION 3 THEORY OF OPERATION (cont)</b>		<b>SECTION 5 ADJUSTMENT PROCEDURE</b>	
ALTERNATE B SWEEP . . . . .	3-18	INTRODUCTION . . . . .	5-1
Run After Delay . . . . .	3-19	PURPOSE . . . . .	5-1
B Delay Time Position		TEST EQUIPMENT REQUIRED . . . . .	5-1
Comparator . . . . .	3-19	LIMITS AND TOLERANCES . . . . .	5-1
B Sweep Logic . . . . .	3-19	PARTIAL PROCEDURES . . . . .	5-1
Alternate Display Switching		ADJUSTMENT INTERACTION . . . . .	5-1
Logic . . . . .	3-20	PREPARATION FOR	
B Z-Axis Logic . . . . .	3-20	ADJUSTMENT . . . . .	5-3
AUTO INTENSITY AND Z-AXIS		INDEX TO ADJUSTMENT	
AMPLIFIER . . . . .	3-21	PROCEDURE . . . . .	5-3
Auto Intensity . . . . .	3-21	POWER SUPPLY AND CRT	
Z-Axis Amplifier . . . . .	3-22	DISPLAY . . . . .	5-4
HORIZONTAL . . . . .	3-23	VERTICAL . . . . .	5-7
Sweep Switching . . . . .	3-24	HORIZONTAL . . . . .	5-13
Horizontal Pre-amplifier . . . . .	3-24	TRIGGERING . . . . .	5-18
XY Amplifier . . . . .	3-24	EXTERNAL Z-AXIS AND	
Horizontal Output Amplifier . . . . .	3-24	PROBE ADJUST. . . . .	5-21
POWER SUPPLY . . . . .	3-25		
Power Input . . . . .	3-25	<b>SECTION 6 MAINTENANCE</b>	
Preregulator . . . . .	3-25	STATIC-SENSITIVE COMPONENTS . . . . .	6-1
Inverter . . . . .	3-26	PREVENTIVE MAINTENANCE . . . . .	6-2
CRT Supply . . . . .	3-27	INTRODUCTION . . . . .	6-2
Auto Focus Circuit . . . . .	3-27	GENERAL CARE . . . . .	6-2
Low-Voltage Supplies . . . . .	3-27	INSPECTION AND CLEANING . . . . .	6-2
DC Restorer . . . . .	3-27	LUBRICATION . . . . .	6-4
		SEMICONDUCTOR CHECKS . . . . .	6-4
<b>SECTION 4 PERFORMANCE CHECK</b>		PERIODIC READJUSTMENT . . . . .	6-4
<b>PROCEDURE</b>		TROUBLESHOOTING . . . . .	6-5
INTRODUCTION . . . . .	4-1	INTRODUCTION . . . . .	6-5
PURPOSE . . . . .	4-1	TROUBLESHOOTING AIDS . . . . .	6-5
TEST EQUIPMENT REQUIRED . . . . .	4-1	TROUBLESHOOTING	
LIMITS AND TOLERANCES . . . . .	4-1	EQUIPMENT . . . . .	6-6
PREPARATION . . . . .	4-1	TROUBLESHOOTING	
INDEX TO PERFORMANCE		TECHNIQUES . . . . .	6-6
CHECK STEPS . . . . .	4-3	CORRECTIVE MAINTENANCE . . . . .	6-10
VERTICAL . . . . .	4-4	INTRODUCTION . . . . .	6-10
HORIZONTAL . . . . .	4-6	MAINTENANCE PRECAUTIONS . . . . .	6-10
TRIGGERING . . . . .	4-9	OBTAINING REPLACEMENT	
EXTERNAL Z-AXIS AND		PARTS . . . . .	6-10
PROBE ADJUST. . . . .	4-12	MAINTENANCE AIDS . . . . .	6-10
		INTERCONNECTIONS . . . . .	6-10

# TABLE OF CONTENTS (cont)

	Page	
<b>SECTION 6 MAINTENANCE (cont)</b>		<b>SECTION 7 OPTIONS</b>
TRANSISTORS AND INTEGRATED CIRCUITS . . . . .	6-11	<b>SECTION 8 REPLACEABLE ELECTRICAL PARTS</b>
SOLDERING TECHNIQUES. . . . .	6-12	<b>SECTION 9 DIAGRAMS</b>
REMOVAL AND REPLACEMENT INSTRUCTIONS. . . . .	6-13	<b>SECTION 10 REPLACEABLE MECHANICAL PARTS</b>
Cabinet . . . . .	6-13	<b>ACCESSORIES</b>
Cathode-Ray Tube. . . . .	6-13	<b>INTERNATIONAL SALES &amp; SERVICE OFFICES</b>
High-Voltage Shield. . . . .	6-14	<b>U.S. SALES &amp; SERVICE OFFICES</b>
Alt Sweep Circuit Board. . . . .	6-14	<b>CHANGE INFORMATION</b>
Attenuator/Sweep Circuit Board . . . . .	6-15	
Front-Panel Circuit Board. . . . .	6-16	
Main Circuit Board . . . . .	6-17	
Current Limit Circuit Board . . . . .	6-18	
REPACKAGING FOR SHIPMENT. . . . .	6-19	

# LIST OF ILLUSTRATIONS

Figure		Page
	The 2215 Oscilloscope	viii
2-1	Power-input-voltage configurations . . . . .	2-2
2-2	Line fuse and power cord . . . . .	2-2
2-3	Power, display, and probe adjust controls, connector, and indicator . . . . .	2-3
2-4	Vertical controls and connectors . . . . .	2-4
2-5	Horizontal controls . . . . .	2-5
2-6	Trigger controls, connector, and indicator . . . . .	2-6
2-7	Rear-panel connector . . . . .	2-8
2-8	Graticule measurement markings . . . . .	2-9
3-1	Basic block diagram of the 2215 Oscilloscope . . . . .	3-3
3-2	Detailed block diagram of the Channel 1 attenuator and attenuator switching tables . . . . .	3-5
3-3	Diode gate biasing for a Channel 1 display . . . . .	3-8
3-4	CHOP VERTICAL MODE waveforms . . . . .	3-11
3-5	A Sweep timing diagram . . . . .	3-16
3-6	Simplified diagram of the Z-Axis Switching Logic circuit . . . . .	3-21
3-7	Detailed block diagram of the Horizontal Amplifier . . . . .	3-23
3-8	Simplified diagram of the DC Restorer circuit. . . . .	3-27
4-1	Test setup for external trigger and jitter checks . . . . .	4-10
6-1	Multipin connector orientation . . . . .	6-7
9-1	Color codes for resistors and capacitors.	
9-2	Semiconductor lead configurations.	
9-3	Locating components on schematic diagrams and circuit board illustrations.	
9-4	2215 block diagram.	
9-5	A12—Attenuator/Sweep board.	
9-6	Circuit view of A12—Attenuator/Sweep board.	
9-7	Circuit view of A10—Main board.	
9-8	A10—Main board.	
9-9	A11—Front Panel board.	
9-10	A19—Current Limit board.	
9-11	A13—Alt Sweep board.	

# LIST OF TABLES

Table		Page
1-1	Electrical Characteristics . . . . .	1-2
1-2	Environmental Characteristics . . . . .	1-6
1-3	Physical Characteristics . . . . .	1-7
4-1	Test Equipment Required . . . . .	4-2
4-2	Deflection Accuracy Limits . . . . .	4-4
4-3	Settings for Bandwidth Checks . . . . .	4-5
4-4	A and B Timing Accuracy . . . . .	4-6
4-5	Settings for Timing Accuracy Checks . . . . .	4-7
4-6	Switch Combinations for A Triggering Checks . . . . .	4-9
5-1	Adjustment Interactions . . . . .	5-2
5-2	Power Supply Limits and Ripple . . . . .	5-5
5-3	Deflection Accuracy Limits . . . . .	5-8
5-4	Attenuator Compensation Adjustments . . . . .	5-10
5-5	Settings for Bandwidth Checks . . . . .	5-11
5-6	A and B Timing Accuracy . . . . .	5-15
5-7	Settings for Timing Accuracy Checks . . . . .	5-15
5-8	Switch Combinations for A Triggering Checks . . . . .	5-19
6-1	Relative Susceptibility to Static-Discharge Damage . . . . .	6-1
6-2	External Inspection Checklist . . . . .	6-3
6-3	Internal Inspection Checklist . . . . .	6-3
6-4	Maintenance Aids . . . . .	6-11

# OPERATORS SAFETY SUMMARY

*The general safety information in this part of the summary is for both operating and servicing personnel. Specific warnings and cautions will be found throughout the manual where they apply and do not appear in this summary.*

## Terms in This Manual

**CAUTION** statements identify conditions or practices that could result in damage to the equipment or other property.

**WARNING** statements identify conditions or practices that could result in personal injury or loss of life.

## Terms as Marked on Equipment

**CAUTION** indicates a personal injury hazard not immediately accessible as one reads the markings, or a hazard to property, including the equipment itself.

**DANGER** indicates a personal injury hazard immediately accessible as one reads the marking.

## Symbols in This Manual



This symbol indicates where applicable cautionary or other information is to be found. For maximum input voltage see Table 1-1.

## Symbols as Marked on Equipment



**DANGER** – High voltage.



Protective ground (earth) terminal.



**ATTENTION** – Refer to manual.

## Power Source

This product is intended to operate from a power source that does not apply more than 250 volts rms between the supply conductors or between either supply conductor and ground. A protective ground connection by way of the grounding conductor in the power cord is essential for safe operation.

## Grounding the Product

This product is grounded through the grounding conductor of the power cord. To avoid electrical shock, plug the power cord into a properly wired receptacle before connecting to the product input or output terminals. A protective ground connection by way of the grounding conductor in the power cord is essential for safe operation.

## Danger Arising From Loss of Ground

Upon loss of the protective-ground connection, all accessible conductive parts (including knobs and controls that may appear to be insulating) can render an electric shock.

## Use the Proper Power Cord

Use only the power cord and connector specified for your product.

Use only a power cord that is in good condition.

For detailed information on power cords and connectors see Figure 2-1.

## Use the Proper Fuse

To avoid fire hazard, use only a fuse of the correct type, voltage rating and current rating as specified in the parts list for your product.

## Do Not Operate in Explosive Atmospheres

To avoid explosion, do not operate this product in an explosive atmosphere unless it has been specifically certified for such operation.

## Do Not Remove Covers or Panels

To avoid personal injury, do not remove the product covers or panels. Do not operate the product without the covers and panels properly installed.



# SERVICING SAFETY SUMMARY

## FOR QUALIFIED SERVICE PERSONNEL ONLY

*Refer also to the preceding Operators Safety Summary.*

### **Do Not Service Alone**

Do not perform internal service or adjustment of this product unless another person capable of rendering first aid and resuscitation is present.

### **Use Care When Servicing With Power On**

Dangerous voltages exist at several points in this product. To avoid personal injury, do not touch exposed connections or components while power is on.

Disconnect power before removing protective panels, soldering, or replacing components.

### **Power Source**

This product is intended to operate from a power source that does not apply more than 250 volts rms between the supply conductors or between either supply conductor and ground. A protective ground connection by way of the grounding conductor in the power cord is essential for safe operation.



The 2215 Oscilloscope.

3826-01

# SPECIFICATION

## INTRODUCTION

The TEKTRONIX 2215 Oscilloscope is a rugged, light-weight, dual-channel, 60-MHz instrument that features a bright, sharply defined trace on an 80- by 100-mm cathode-ray tube (crt). Its vertical system provides calibrated deflection factors from 2 mV per division to 10 V per division. Trigger circuits enable stable triggering over the full bandwidth of the vertical system. The horizontal system provides calibrated sweep speeds from 0.5 s per division to 50 ns per division along with delayed-sweep features for accurate relative-time measurements. A X10 magnifier extends the maximum sweep speed to 5 ns per division.

## ACCESSORIES

The instrument is shipped with the following standard accessories:

- |                    |                      |
|--------------------|----------------------|
| 1 Operators manual | 2 Probe packages     |
| 1 Service manual   | 2 Probe grabber tips |

For part numbers and further information about both standard and optional accessories, refer to the "Accessories" page at the back of this manual. Your Tektronix representative, your local Tektronix Field Office, or the Tektronix product catalog can also provide accessories information.

## PERFORMANCE CONDITIONS

The following electrical characteristics (Table 1-1) are valid for the 2215 when it has been adjusted at an ambient temperature between +20°C and +30°C, has had a warm-up period of at least 20 minutes, and is operating at an ambient temperature between 0°C and +50°C (unless otherwise noted).

Items listed in the "Performance Requirements" column are verifiable qualitative or quantitative limits, while items listed in the "Supplemental Information" column are either explanatory notes, calibration setup descriptions, performance characteristics for which no absolute limits are specified, or characteristics that are impractical to check.

Environmental characteristics are given in Table 1-2. The 2215 meets the requirements of MIL-T-28800B, Class 5 equipment, except where otherwise noted.



Physical characteristics of the instrument are listed in Table 1-3.

Table 1-1  
Electrical Characteristics

Characteristics	Performance Requirements	Supplemental Information
<b>VERTICAL DEFLECTION SYSTEM</b>		
Deflection Factor		1X gain adjusted with VOLTS/DIV switch set to 20 mV per division.  10X gain adjusted with VOLTS/DIV switch set to 2 mV per division.
Range	2 mV per division to 10 V per division in a 1-2-5 sequence.	
Accuracy +20°C to +30°C	±3%.	
0°C to +50°C	±4%. <sup>a</sup>	
Range of VOLTS/DIV Variable Control.	Continuously variable between settings. Increases deflection factor by at least 2.5 to 1.	
Step Response		Measured with a vertically centered 5-division reference signal from a 50-Ω source driving a 50-Ω coaxial cable that is terminated in 50 Ω at the input connector, with the VOLTS/DIV Variable control in its CAL detent.
Rise Time		5.8 ns or less.  Rise time is calculated from the formula:  Rise Time = $\frac{0.35}{\text{BW (in MHz)}}$
Bandwidth		Measured with a vertically centered 6-division reference signal from a 50-Ω source driving a 50-Ω coaxial cable that is terminated in 50 Ω, both at the input connector and at the P6120 probe input, with the VOLTS/DIV Variable control in its CAL detent.
0°C to +40°C 20 mV to 10 V per Division	Dc to at least 60 MHz.	
2 mV to 10 mV per Division	Dc to at least 50 MHz.	
+40°C to +50°C 2 mV to 10 V per Division	Dc to at least 50 MHz. <sup>a</sup>	
Chop Mode Repetition Rate		250 kHz ±30%.

<sup>a</sup>Performance Requirement not checked in Service Manual.

Table 1-1 (cont)

Characteristics	Performance Requirements	Supplemental Information
<b>VERTICAL DEFLECTION SYSTEM (cont)</b>		
Input Characteristics		
Resistance	1 M $\Omega$ $\pm$ 2%. <sup>a</sup>	
Capacitance	30 pF $\pm$ 3 pF. <sup>a</sup>	
Maximum Safe Input Voltage 		
DC Coupled	400 V (dc + peak ac) or 800 V p-p ac to 1 kHz or less. <sup>a</sup>	
AC Coupled	400 V (dc + peak ac) or 800 V p-p ac to 1 kHz or less. <sup>a</sup>	
Common-Mode Rejection Ratio (CMRR)	At least 10 to 1 at 10 MHz.	Checked at 20 mV per division for common-mode signals of 8 divisions or less, with VOLTS/DIV Variable control adjusted for best CMRR at 50 kHz.
<b>TRIGGER SYSTEM</b>		
A Trigger Sensitivity		
AUTO and NORM	0.4 division internal or 50 mV external to 2 MHz, increasing to 1.5 divisions internal or 250 mV external at 60 MHz.	External trigger signal from a 50- $\Omega$ source driving a 50- $\Omega$ coaxial cable that is terminated in 50 $\Omega$ at the input connector.  Will trigger on tv line sync components in NORM only: $\geq$ 0.4 division internal or 50 mV p-p external.
AUTO Lowest Usable Frequency	20 Hz. <sup>a</sup>	
TV FIELD	2.0 divisions of composite video or composite sync. <sup>a</sup>	
B Trigger Sensitivity		
Internal	0.4 division to 2 MHz, increasing to 2.0 divisions at 60 MHz.	
External Input		
Maximum Input Voltage 	400 V (dc + peak ac) or 800 V p-p ac at 1 kHz or less. <sup>a</sup>	
Input Resistance	1 M $\Omega$ $\pm$ 2%. <sup>a</sup>	
Input Capacitance	30 pF $\pm$ 3 pF. <sup>a</sup>	
AC Coupled	10 Hz or less at lower $-3$ dB point. <sup>a</sup>	

<sup>a</sup>Performance Requirement not checked in Service Manual.

Table 1-1 (cont)

Characteristics	Performance Requirements	Supplemental Information
<b>TRIGGER SYSTEM (cont)</b>		
LEVEL Control Range		
A Trigger (NORM)		
INT	On screen limits. <sup>a</sup>	
EXT and DC	At least $\pm 2$ V (4 V p-p). <sup>a</sup>	
EXT and DC $\div 10$	At least $\pm 20$ V (40 V p-p). <sup>a</sup>	
B Trigger		
Internal	On screen limits. <sup>a</sup>	
VAR HOLDOFF Control Range	Increases the A Sweep holdoff time by at least a factor of four. <sup>a</sup>	
<b>HORIZONTAL DEFLECTION SYSTEM</b>		
Sweep Rate		
Calibrated Range		
A Sweep	0.5 s per division to 0.05 $\mu$ s per division in a 1-2-5 sequence. X10 Magnifier extends maximum sweep speed to 5 ns per division.	
B Sweep	50 ms per division to 0.05 $\mu$ s per division in a 1-2-5 sequence. X10 Magnifier extends maximum sweep speed to 5 ns per division.	
Accuracy	<b>Unmagnified</b>	<b>Magnified</b>
$+20^{\circ}\text{C}$ to $+30^{\circ}\text{C}$	$\pm 3\%$	$\pm 5\%$
$0^{\circ}\text{C}$ to $+50^{\circ}\text{C}$	$\pm 4\%$ <sup>a</sup>	$\pm 6\%$ <sup>a</sup>
POSITION Control Range	Start of sweep to 100th division will position past the center vertical graticule line with X10 Magnifier.	
Variable Control Range	Continuously variable between calibrated settings. Extends both the A and B sweep speeds by at least a factor of 2.5.	
Delay Time	Applies to sweep-speed settings of 0.5 $\mu$ s per division and slower.	Delay time is functional but is not calibrated at sweep-speed settings above 0.5 $\mu$ s per division.
B DELAY TIME POSITION Control Range	Less than 0.5 division to more than 10 divisions.	

<sup>a</sup>Performance Requirement not checked in Service Manual.

Table 1-1 (cont)

Characteristics	Performance Requirements	Supplemental Information
<b>HORIZONTAL DEFLECTION SYSTEM (cont)</b>		
Delay Time (cont)		
Jitter	One part, or less, in 10,000 (0.01%) of the maximum available delay time.	
Dial Accuracy	±1.5% of full scale.	
<b>X-Y OPERATION (X1 MAGNIFICATION)</b>		
Deflection Factors		
Range	Same as Vertical Deflection System, with both VOLTS/DIV Variable controls in CAL detent.	
Accuracy	<b>X-Axis</b> <b>Y-Axis</b>	Measured with a dc-coupled, 5-division reference signal.
+20°C to +30°C	±5%      ±3%	
0°C to +50°C	±6% <sup>a</sup> +4% <sup>a</sup>	
Bandwidth		Measured with a 5-division reference signal.
X-Axis	Dc to at least 2 MHz.	
Y-Axis	Same as Vertical Deflection System.	
Phase Difference Between X- and Y-Axis Amplifiers	±3° from dc to 50 kHz. <sup>a</sup>	With dc-coupled inputs.
<b>PROBE ADJUST</b>		
Signal at PROBE ADJUST Jack		
Voltage	0.5 V ±20%.	
Repetition Rate	1 kHz ±20%. <sup>a</sup>	
<b>Z-AXIS INPUT</b>		
Sensitivity	5 V causes noticeable modulation. Positive-going input signal decreases intensity.	
Usable Frequency Range	Dc to 5 MHz. <sup>a</sup>	
Maximum Safe Input Voltage	30 V (dc + peak ac) or 30 V p-p ac at 1 kHz or less. <sup>a</sup>	
Input Impedance	10 kΩ ±10%. <sup>a</sup>	

<sup>a</sup>Performance Requirement not checked in Service Manual.

Table 1-1 (cont)

Characteristics	Performance Requirements	Supplemental Information
<b>POWER SOURCE</b>		
Line Voltage Range	90 V to 250 V. <sup>a</sup>	
Line Frequency Range	48 Hz to 62 Hz. <sup>a</sup>	
Maximum Power Consumption	50 W. <sup>a</sup>	
Line Fuse	2 A, 250 V, fast.	
<b>CATHODE-RAY TUBE</b>		
Display Area	80 by 100 mm. <sup>a</sup>	
Standard Phosphor	P31. <sup>a</sup>	
Nominal Accelerating Voltage	10,000 V. <sup>a</sup>	

<sup>a</sup>Performance Requirement not checked in Service Manual.

Table 1-2  
Environmental Characteristics

Characteristics	Description
	<b>NOTE</b> <i>The instrument meets all of the following MIL-T-28800B requirements for Class 5 equipment.</i>
Temperature	
Operating	0°C to +50°C (+32°F to +122°F).
Nonoperating	-55°C to +75°C (-67°F to +167°F).
Altitude	
Operating	To 4,500 m (15,000 ft). Maximum operating temperature decreased 1°C per 300 m (1,000 ft) above 1,500 m (5,000 ft).
Nonoperating	To 15,000 m (50,000 ft).
Humidity (Operating and Nonoperating)	5 cycles (120 hours) referenced to MIL-T-28800B, Class 5 instruments.
Vibration (Operating)	15 minutes along each of 3 major axes at a total displacement of 0.015 inch p-p (2.4 g at 55 Hz), with frequency varied from 10 Hz to 55 Hz to 10 Hz in 1-minute sweeps. Hold for 10 minutes at 55 Hz. All major resonances must be above 55 Hz.
Shock (Operating and Nonoperating)	30 g, half-sine, 11-ms duration; 3 shocks per axis each direction, for a total of 18 shocks.



**Table 1-3**  
**Physical Characteristics**

<b>Characteristics</b>	<b>Description</b>
<b>Weight</b>	
With Front-Panel Cover, Accessories, and Pouch	7.6 kg (16.8 lb).
Without Front-Panel Cover, Accessories, and Pouch	6.1 kg (13.5 lb).
Domestic Shipping	8.2 kg (18.0 lb).
<b>Height With Feet and Handle</b>	137 mm (5.4 in).
<b>Width</b>	
With Handle	361 mm (14.2 in).
Without Handle	328 mm (12.9 in).
<b>Depth</b>	
With Front-Panel Cover	445 mm (17.5 in).
Without Front-Panel Cover	439 mm (17.3 in).
With Handle Extended	511 mm (20.1 in).

# OPERATING INSTRUCTIONS

## PREPARATION FOR USE

### SAFETY

Refer to the Safety Summaries at the front of this manual for power source, grounding, and other safety considerations pertaining to the use of the 2215. Before connecting the instrument to a power source, carefully read the following information about line voltages, power cords, and fuses; then verify that the proper power-input fuse is installed.

### LINE VOLTAGE

The instrument is capable of continuous operation using ac-power-input voltages that range from 90 V to 250 V nominal at frequencies from 48 Hz to 62 Hz.

### POWER CORD



For the 120-V North American customer, the 2215 is delivered with a three-wire power cord permanently attached. At the end of the cord is a three-contact plug for connection to the power source and to protective ground. The plug's protective-ground contact connects (through the protective-ground conductor) to the accessible metal parts of the instrument. For electrical-shock protection, insert this plug only into a power-source outlet that has a securely grounded protective-ground contact.

For the non-North American customer (and for the 240-V North American user), the appropriate power cord is supplied by an option that is specified when the instrument is ordered. The optional power cords available are illustrated in Figure 2-1.

### LINE FUSE

The instrument fuse holder is located on the rear panel (see Figure 2-2) and contains the line fuse. Verify that the proper fuse is installed by performing the following procedure:

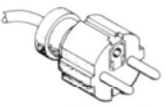
1. Unplug the power cord from the power-input source (if applicable).
2. Press in and slightly rotate the fuse-holder cap counterclockwise to release it.
3. Pull out the cap from the fuse holder, with the fuse attached to the inside of the cap.
4. Note fuse values and verify proper size (2 A, 250 V, fast-blow).
5. Reinstall the fuse and fuse-holder cap.

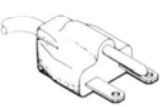
Plug Configuration	Category	Power Cord and Plug Type	Factory Installed Instrument Fuse	Fuse Holder Cap	Line Cord Plug Fuse
	U.S. Domestic Standard	US 120V 15A	2 A, 250 V Fast-blow AGC/3AG	AGC/3AG	None
	Option A1	Euro 240V 10-16A	2 A, 250 V Fast-blow 5x20 mm	5x20 mm	None
	Option A2	UK 240V 13A	2 A, 250 V Fast-blow 5x20 mm	5x20 mm	13A Type C
	Option A3	Australian 240V 10A	2 A, 250 V Fast-blow 5x20 mm	5x20 mm	None
	Option A4	North America 240V 15A	2 A, 250 V Fast-blow AGC/3AG	AGC/3AG	None

3397-03

Figure 2-1. Power-input-voltage configurations.

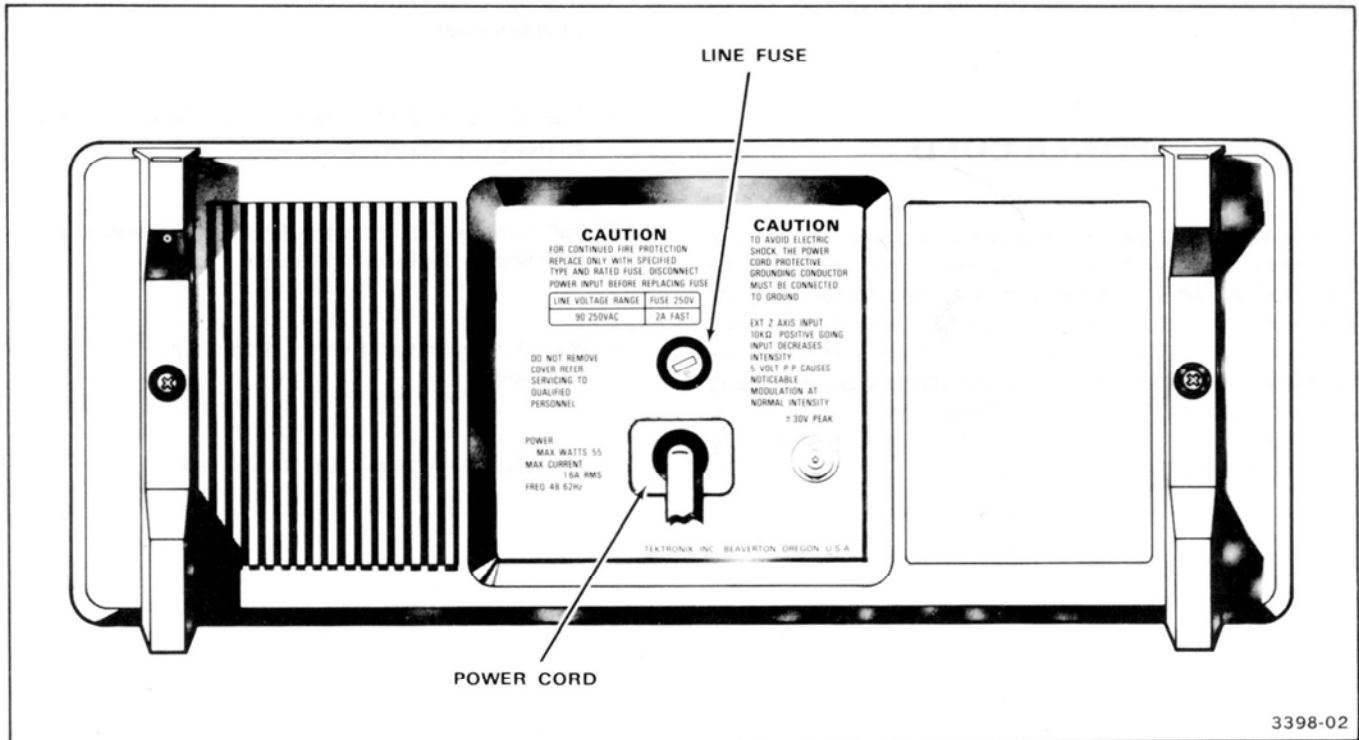

Figure 2-2. Line fuse and power cord.

# CONTROLS, CONNECTORS, AND INDICATORS

The following descriptions are intended to familiarize the operator with the location, operation, and function of the instrument's controls, connectors, and indicators.

## POWER, DISPLAY, AND PROBE ADJUST

Refer to Figure 2-3 for location of items 1 through 7.

- ① **Internal Graticule**—Eliminates parallax viewing error between the trace and graticule lines. Rise-time amplitude and measurement points are indicated at the left edge of the graticule.
- ② **POWER Switch**—Turns instrument power on and off. Press in for ON; press again for OFF.
- ③ **AUTO FOCUS Control**—Adjusts display for optimum definition. Once set, the focus of the crt display will

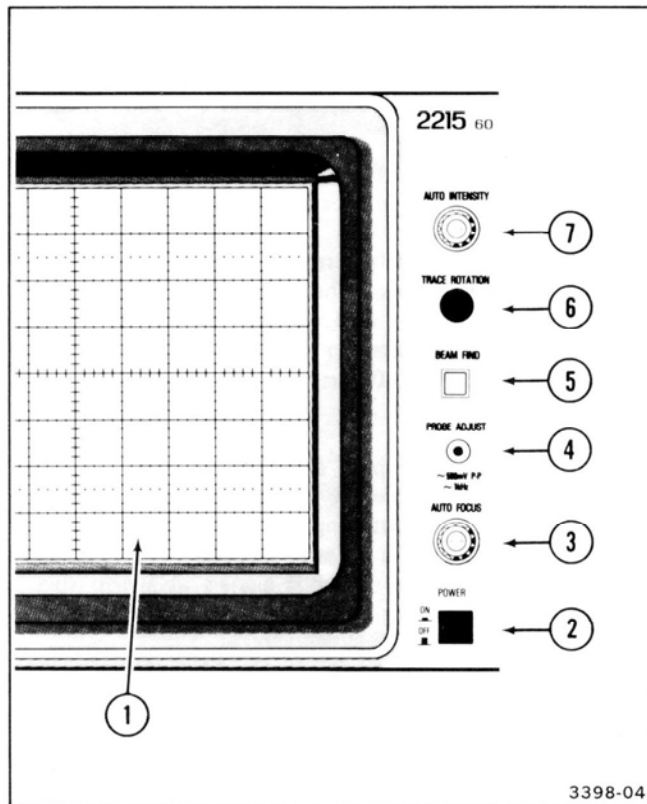

Figure 2-3. Power, display, and probe adjust controls, connector, and indicator.

be maintained as changes occur in the intensity level of the trace.

- ④ **PROBE ADJUST Connector**—Provides an approximately 0.5-V, negative-going, square-wave voltage (at approximately 1 kHz) that permits the operator to compensate voltage probes and to check operation of the oscilloscope vertical system. It is not intended to verify the accuracy of the vertical gain or time-base calibration.
- ⑤ **BEAM FIND Switch**—When held in, compresses the display to within the graticule area and provides a visible viewing intensity to aid in locating off-screen displays.
- ⑥ **TRACE ROTATION Control**—Screwdriver control used to align the crt trace with the horizontal graticule lines.
- ⑦ **AUTO INTENSITY Control**—Adjusts brightness of the crt display. This control has no effect when the BEAM FIND switch is pressed in. Once the control is set, intensity is automatically maintained at approximately the same level between SEC/DIV switch settings from 0.5 ms per division to 0.05  $\mu$ s per division.

## VERTICAL

Refer to Figure 2-4 for location of items 8 through 16.

- ⑧ **SERIAL and Mod Slots**—The SERIAL slot is imprinted with the instrument's serial number. The Mod slot contains the option number that has been installed in the instrument.
- ⑨ **CH 1 OR X and CH 2 OR Y Connectors**—Provide for application of external signals to the inputs of the vertical deflection system or for an X-Y display. In the X-Y mode, the signal connected to the CH 1 OR X connector provides horizontal deflection, and the signal connected to the CH 2 OR Y connector provides vertical deflection.
- ⑩ **GND Connector**—Provides direct connection to instrument chassis ground.

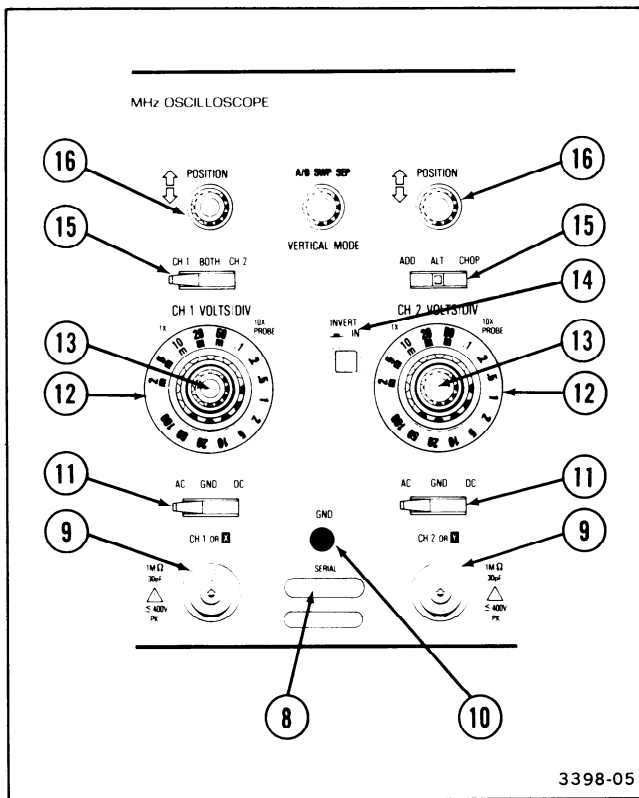

Figure 2-4. Vertical controls and connectors.

**11** **Input Coupling (AC-GND-DC) Switches**—Used to select the method of coupling input signals to the vertical deflection system.

**AC**—Input signal is capacitively coupled to the vertical amplifier. The dc component of the input signal is blocked. Low-frequency limit (–3 dB point) is approximately 10 Hz.

**GND**—The input of the vertical amplifier is grounded to provide a zero (ground) reference-voltage display (does not ground the input signal). This switch position allows precharging the input coupling capacitor.

**DC**—All frequency components of the input signal are coupled to the vertical deflection system.

**12** **CH 1 VOLTS/DIV and CH 2 VOLTS/DIV Switches**—Used to select the vertical deflection factor in a 1-2-5 sequence. To obtain a calibrated deflection factor, the VOLTS/DIV variable control must be in detent.

**1X PROBE**—Indicates the deflection factor selected when using either a 1X probe or a coaxial cable.

**10X PROBE**—Indicates the deflection factor selected when using a 10X probe.

**13** **VOLTS/DIV Variable Controls**—When rotated counterclockwise out of their detent positions, these controls provide continuously variable, uncalibrated deflection factors between the calibrated settings of the VOLTS/DIV switches. Extends maximum uncalibrated deflection factor to 25 volts per division with 1X probe (a range of at least 2.5:1).

**14** **INVERT Switch**—Inverts the Channel 2 display when button is pressed in. Push button must be pressed in a second time to release it and regain a noninverted display.

**15** **VERTICAL MODE Switches**—Two three-position switches are used to select the mode of operation for the vertical amplifier system.

**CH 1**—Selects only the Channel 1 input signal for display.

**BOTH**—Selects both Channel 1 and Channel 2 input signals for display. The BOTH position must be selected for either ADD, ALT, or CHOP operation.

**CH 2**—Selects only the Channel 2 input signal for display.

**ADD**—Displays the algebraic sum of the Channel 1 and Channel 2 input signals.

**ALT**—Alternately displays Channel 1 and Channel 2 input signals. The alternation occurs during retrace at the end of each sweep. This mode is useful for viewing both input signals at sweep speeds from 0.05  $\mu$ s per division to 0.2 ms per division.

**CHOP**—The display switches between the Channel 1 and Channel 2 input signals during the sweep. The switching rate is approximately 250 kHz. This mode is useful for viewing both Channel 1 and Channel 2 input signals at sweep speeds from 0.5 ms per division to 0.5 s per division.

**16** **POSITION Controls**—Used to vertically position the display on the crt. When the SEC/DIV switch is set to X-Y, the Channel 2 POSITION control moves the display vertically (Y-axis), and the Horizontal POSITION control moves the display horizontally (X-axis).

## HORIZONTAL

Refer to Figure 2-5 for location of items 17 through 23.

**17 B DELAY TIME POSITION Control**—Selects the amount of delay time between the start of the A Sweep and the start of the B Sweep. Delay time is variable from 0.5 times to 10 times the A SEC/DIV switch setting.

**18 A and B SEC/DIV Switches**—Used to select the sweep speeds for the A and B Sweep generators in a 1-2-5 sequence. For calibrated sweep speeds, the A and B SEC/DIV Variable control must be in the calibrated detent (fully clockwise).

**A SEC/DIV**—The A Sweep speed is shown between the two black lines on the clear plastic skirt. This switch also selects the delay time for delayed-sweep operation (used in conjunction with the B DELAY TIME POSITION control).

**B SEC/DIV**—The B Sweep speed is set by pulling out the DLY'D SWEEP knob and rotating it clockwise to a setting shown by the white line scribed on the knob. The B Sweep circuit is used only for delayed-sweep operation.

**19 A and B SEC/DIV Variable Control**—Provides continuously variable, uncalibrated A Sweep speeds to at least 2.5 times the calibrated setting. It extends the slowest sweep speed to at least 1.25 s per division.

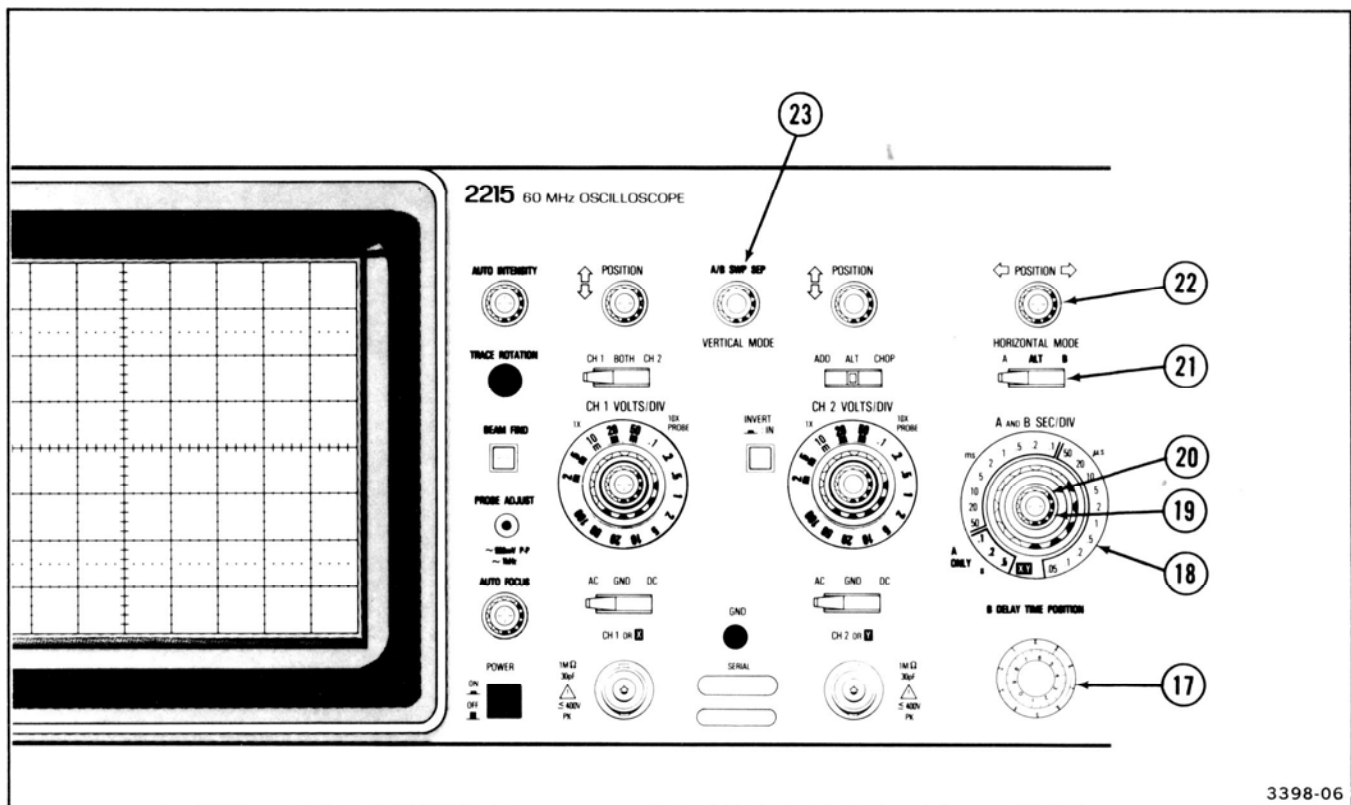

Figure 2-5. Horizontal controls.

20 **X10 Magnifier Switch**—To increase displayed sweep speed by a factor of 10, pull out the A and B SEC/DIV Variable knob. The fastest sweep speed can be extended to 5 ns per division. Push in the A and B SEC/DIV Variable control knob to regain the X1 sweep speed.

21 **HORIZONTAL MODE Switch**—This three-position switch determines the mode of operation for the horizontal deflection system.

**A**—Horizontal deflection is provided by the A Sweep generator at a sweep speed determined by the A SEC/DIV switch setting.

**B**—Horizontal deflection is provided by the B Sweep generator at a sweep speed determined by the setting of the B SEC/DIV switch. The start of the B Sweep is delayed from the start of the A Sweep by a time determined by the settings of both the A SEC/DIV switch and the B DELAY TIME POSITION control.

**ALT**—Alternates the horizontal displays between the A Sweep (with an intensified zone) and the B Delayed Sweep. The A Sweep speed is determined by the setting of the A SEC/DIV switch. The length of the intensified zone on the A Sweep (the B Sweep speed) is determined by the setting of the B SEC/DIV switch.

22 **POSITION Control**—Positions the display horizontally for the A Sweep and the B Sweep. In the X-Y mode, horizontally positions the X-axis.

23 **A/B SWP SEP Control**—Vertically positions the B Sweep trace with respect to the A Sweep trace when ALT HORIZONTAL MODE is selected.

## TRIGGER

Refer to Figure 2-6 for locations of items 24 through 33.

24 **EXT INPUT Connector**—Provides a means of introducing external signals into the A Trigger generator.

25 **A EXT COUPLING Switch**—Determines the method used to couple external signals to the A Trigger circuit.

**AC**—Signals above 60 Hz are capacitively coupled to the input of the A Trigger circuit. Any dc components are blocked, and signals below 60 Hz are attenuated.

**DC**—All components of the signal are coupled to the A Trigger circuitry. This position is useful for displaying low-frequency or low-repetition-rate signals.

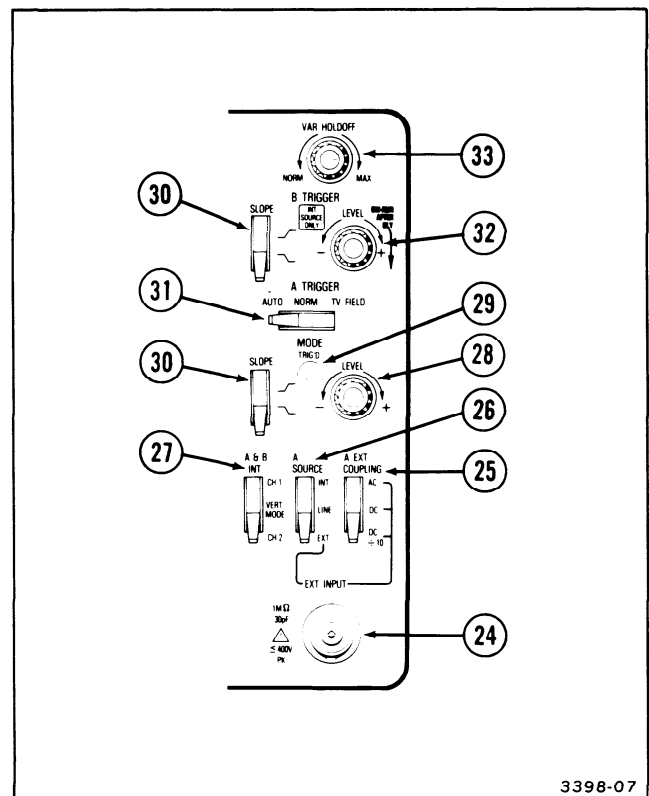

Figure 2-6. Trigger controls, connector, and indicator.

**DC÷10**—External trigger signals are attenuated by a factor of 10.

- 26 **A SOURCE Switch**—Determines the source of the trigger signal that is coupled to the input of the A Trigger circuit.

**INT**—Permits triggering on signals that are applied to the CH 1 OR X and CH 2 OR Y input connectors. The source of the internal signal is selected by the A & B INT switch.

**LINE**—Provides a triggering signal from a sample of the ac-power-source waveform. This trigger source is useful when channel-input signals are time related (multiple or submultiple) to the frequency on the power-source-input voltage.

**EXT**—Permits triggering on signals applied to the EXT INPUT connector.

- 27 **A & B INT Switch**—Selects the source of the triggering signal when the A SOURCE switch is set to INT.

**CH 1**—The signal applied to the CH 1 OR X input connector is the source of the trigger signal.

**VERT MODE**—The internal trigger source is determined by the signals selected for display by the VERTICAL MODE switches.

**CH 2**—The signal applied to the CH 2 OR Y input connector is the source of the trigger signal.

- 28 **A TRIGGER LEVEL Control**—Selects the amplitude point on the trigger signal at which the sweep is triggered.

- 29 **TRIG'D Indicator**—The light-emitting diode (LED) illuminates to indicate that the A Sweep is triggered.

- 30 **SLOPE Switches**—Used to select the slope of the signal that triggers the sweep (also refer to TV Signal Displays at the end of Section 2).

—Sweep is triggered on the positive-going portion of the trigger signal.

—Sweep is triggered on the negative-going portion of the trigger signal.

- 31 **A TRIGGER MODE Switch**—Determines the trigger mode for the A Sweep.

**AUTO**—Permits triggering on waveforms having repetition rates of at least 20 Hz. Sweep free-runs in the absence of an adequate trigger signal or when the repetition rate is below 20 Hz. The range of the A TRIGGER LEVEL control is automatically set to the peak-to-peak range of the trigger level.

**NORM**—Sweep is initiated when an adequate trigger signal is applied. In the absence of a trigger signal, no baseline trace will be present. Triggering on television lines is accomplished in this mode.

**TV FIELD**—Permits triggering on television field signals (refer to TV Signal Displays at the end of Section 2).

- 32 **B TRIGGER LEVEL Control**—Selects the amplitude point on the trigger signal at which the sweep is triggered. When fully clockwise (CW-RUN AFTER DLY), the B Sweep circuit runs immediately following the delay time selected by the A SEC/DIV switch and the B DELAY TIME POSITION control.

- 33 **VAR HOLDOFF Control**—Provides continuous control of holdoff time between sweeps. Increases the holdoff time by at least a factor of four. This control improves the ability to trigger on aperiodic signals (such as complex digital waveforms).



## REAR PANEL

Refer to Figure 2-7 for location of item 34.

- 34 EXT Z AXIS Connector—Provides a means of connecting external signals to the Z-axis amplifier to

intensity modulate the crt display. Applied signals do not affect display waveshape. Signals with fast rise times and fall times provide the most abrupt intensity change, and a 5-V p-p signal will produce noticeable modulation. The Z-axis signals must be time-related to the display to obtain a stable presentation on the crt.

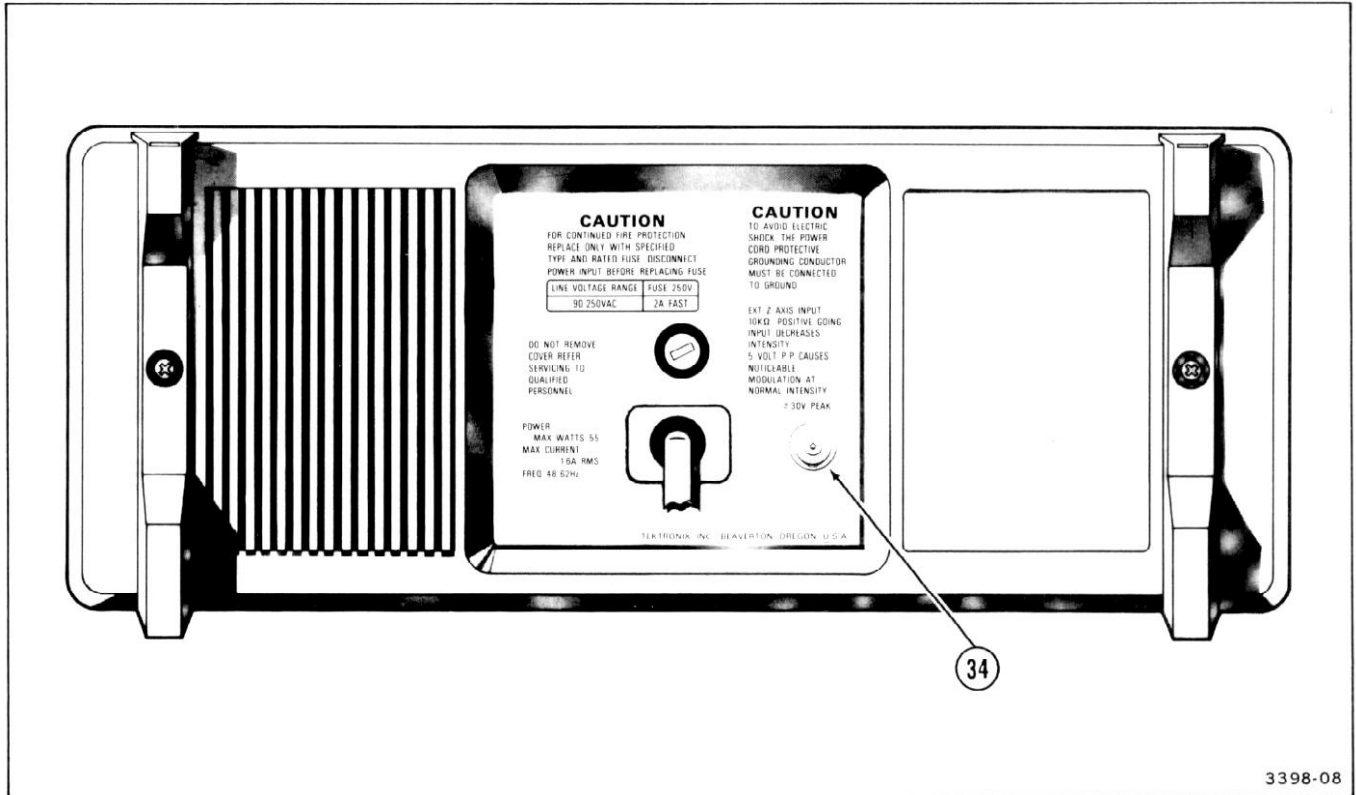

Figure 2-7. Rear-panel connector.

# OPERATING CONSIDERATIONS

The following basic operating information and techniques should be considered before attempting any measurements.

## GRATICULE

The graticule is internally marked on the faceplate of the crt to enable accurate measurements without parallax error (see Figure 2-8). It is marked with eight vertical and ten horizontal major divisions. Each major division is divided into five subdivisions. The vertical deflection factors and horizontal timing are calibrated to the graticule so that accurate measurements can be made directly from the crt. Also, percentage markers for the measurement of rise and fall times are located on the left side of the graticule.

## GROUNDING

The most reliable signal measurements are made when the 2215 and the unit under test are connected by a common reference (ground lead), in addition to the signal lead or probe. The probe's ground lead provides the best grounding method for signal interconnection and ensures the maximum amount of signal-lead shielding in the probe cable. A separate ground lead can also be connected from the unit under test to the oscilloscope GND connector located on the front panel.

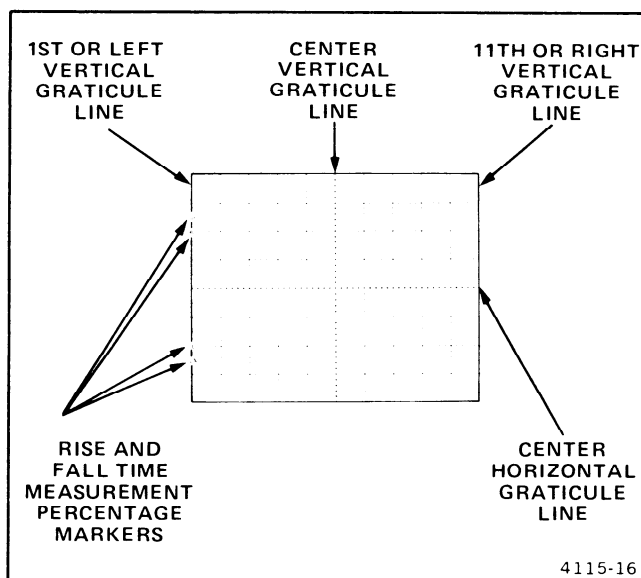

Figure 2-8. Graticule measurement markings.

## SIGNAL CONNECTIONS

Generally, probes offer the most convenient means of connecting an input signal to the instrument. They are shielded to prevent pickup of electromagnetic interference, and the supplied 10X probe offers a high input impedance that minimizes circuit loading. This allows the circuit under test to operate with a minimum of change from its normal condition as measurements are being made.

Coaxial cables may also be used to connect signals to the input connectors, but they may have considerable effect on the accuracy of a displayed waveform. To maintain the original frequency characteristics of an applied signal, only high-quality, low-loss coaxial cables should be used. Coaxial cables should be terminated at both ends in their characteristic impedance. If this is not possible, use suitable impedance-matching devices.

## INPUT COUPLING CAPACITOR PRECHARGING

When the input coupling switch is set to GND, the input signal is connected to ground through the input coupling capacitor in series with a 1-M $\Omega$  resistor to form a precharging network. This network allows the input coupling capacitor to charge to the average dc-voltage level of the signal applied to the probe. Thus, any large voltage transients that may accidentally be generated will not be applied to the amplifier input when the input coupling switch is moved from GND to AC. The precharging network also provides a measure of protection to the external circuitry by reducing the current levels that can be drawn from the external circuitry during capacitor charging.

The following procedure should be used whenever the probe tip is connected to a signal source having a different dc level than that previously applied, especially if the dc-level difference is more than 10 times the VOLTS/DIV switch setting:

1. Set the AC-GND-DC switch to GND before connecting the probe tip to a signal source.
2. Insert the probe tip into the oscilloscope GND connector.

3. Wait several seconds for the input coupling capacitor to discharge.

4. Connect the probe tip to the signal source.

5. Wait several seconds for the input coupling capacitor to charge.

6. Set the AC-GND-DC switch to AC. The display will remain on the screen, and the ac component of the signal can be measured in the normal manner.

## INSTRUMENT COOLING

To maintain adequate instrument cooling, the ventilation holes on both sides and rear panel of the equipment cabinet must remain free of obstructions.

# OSCILLOSCOPE DISPLAYS

## INTRODUCTION

The procedure in this section will allow you to set up and operate your instrument to obtain the most commonly used oscilloscope displays. Before starting this procedure, verify that the POWER switch is OFF (push button out), then plug the power cord into an approved ac-power-source outlet.

## BASELINE TRACE

First obtain a baseline trace.

1. Preset the instrument front-panel controls as follows:

### Display

AUTO INTENSITY	Fully counterclockwise (minimum)
AUTO FOCUS	Midrange

### Vertical (Both Channels)

AC-GND-DC	AC
VOLTS/DIV	50 m (1X)
VOLTS/DIV Variable	CAL detent (fully clockwise)
VERTICAL MODE	CH 1
INVERT	Off (button out)
POSITION	Midrange

### Horizontal

A and B SEC/DIV	Locked together at 0.5 ms
A and B SEC/DIV Variable	CAL detent (fully clockwise)
HORIZONTAL MODE	A
X10 Magnifier	Off (variable knob in)
POSITION	Midrange
B DELAY TIME	Fully counterclockwise
POSITION	Midrange
A/B SWP SEP	Midrange

### A Trigger

VAR HOLDOFF	NORM (fully counterclockwise)
SLOPE	 (lever up)
LEVEL	Midrange
MODE	AUTO
A EXT COUPLING	AC
A SOURCE	INT
A & B INT	VERT MODE

### B Trigger

SLOPE	 (lever up)
LEVEL	Fully clockwise

2. Press in the POWER switch button (ON) and allow the instrument to warm up for 20 minutes.

3. Adjust the AUTO INTENSITY control for desired display brightness.

4. Adjust the Vertical and Horizontal POSITION controls to center the trace on the screen.

## SIGNAL DISPLAY

1. Obtain a baseline trace.

2. Apply a signal to either vertical-channel input connector and set the VERTICAL MODE switch to display the channel used. To display two time-related input signals use both vertical-channel input connectors and select BOTH VERTICAL MODE; then select either ALT or CHOP, depending on the frequency of input signals.

3. Adjust the AUTO INTENSITY control for desired display brightness. If the display is not visible with the AUTO INTENSITY control at midrange, press the BEAM FIND push button and hold it in while adjusting the appropriate VOLTS/DIV switch(es) to reduce the vertical display size. Center the compressed display within the graticule area using the Vertical and Horizontal POSITION controls, then release the BEAM FIND push button.

4. Adjust the A TRIGGER LEVEL control, if necessary, to obtain a stable display.

5. Set the appropriate VOLTS/DIV switch(es) and readjust the Vertical and Horizontal POSITION controls to center the display within the graticule area.

6. Set the A SEC/DIV switch for the desired number of cycles of the displayed signal. Then adjust the AUTO FOCUS control for the best-defined display.

### MAGNIFIED-SWEEP DISPLAY

1. Obtain a Signal Display (see preceding instructions).

2. Adjust the Horizontal POSITION control to move the trace area that is to be magnified to the center of the crt graticule (0.5 division on each side of the center vertical graticule line). Change the A SEC/DIV switch setting as required.

3. Pull out the A and B SEC/DIV Variable knob (X10) to obtain sweep magnification.

4. Adjust the Horizontal POSITION control for precise positioning of the magnified display.

5. To calculate the magnified sweep speed, divide the A SEC/DIV switch setting by 10.

### DELAYED-SWEEP DISPLAY

1. Obtain a Signal Display.

2. Select ALT HORIZONTAL MODE. Adjust the appropriate channel POSITION control and the A/B SWP SEP control to display the A trace above the B trace.

3. Adjust the AUTO INTENSITY control as needed to make the intensified zone distinguishable from the remainder of the display. Set the B SEC/DIV switch until the intensified zone is the desired length.

4. Adjust the B DELAY TIME POSITION control to move the intensified zone to cover that portion of the A trace that is to be displayed on the B trace. The B HORIZONTAL MODE may be used to display the intensified portion of the A Sweep.

### DELAYED-SWEEP MEASUREMENTS

1. Obtain a Signal Display.

2. Select ALT HORIZONTAL MODE. Adjust the appropriate channel POSITION control and the A/B SWP SEP control to display the A trace above the B trace.

3. Adjust the AUTO INTENSITY control as needed to make the intensified zone distinguishable from the remainder of the display. Set the B SEC/DIV switch until the intensified zone is the desired length.

4. Adjust the B DELAY TIME POSITION control to move the intensified zone to the leading edge of the first pulse of interest; then fine adjust until the rising portion is centered at any convenient vertical graticule line.

5. Record the B DELAY TIME POSITION control dial setting.

6. Adjust the B DELAY TIME POSITION control clockwise until the rising portion of the second pulse of interest is positioned to the same vertical reference line selected in step 4.

7. Record the B DELAY TIME POSITION control dial setting.

8. Use the following formula to calculate the time difference:

$$\text{Time Difference (delayed sweep)} = \left( \begin{array}{c} \text{second} \\ \text{dial} \\ \text{setting} \end{array} - \begin{array}{c} \text{first} \\ \text{dial} \\ \text{setting} \end{array} \right) \left( \begin{array}{c} \text{A SEC/DIV} \\ \text{switch setting} \\ \text{(delay time)} \end{array} \right)$$

## X-Y DISPLAY

1. Obtain a baseline trace.
2. Use equal-length coaxial cables, or the two 10X probes supplied with the instrument, to apply the horizontal signal (X-axis) to the CH 1 OR X input connector and to apply the vertical signal (Y-axis) to the CH 2 OR Y input connector.
3. Select X-Y mode by switching the A SEC/DIV switch to its fully counterclockwise position.
4. Advance the AUTO INTENSITY control setting until two dots are displayed. The display can be positioned horizontally with the Horizontal POSITION control and vertically with the Channel 2 POSITION control.

### NOTE

*The display obtained when sinusoidal signals are applied to the X- and Y-axis is called a Lissajous figure. This display is commonly used to compare the frequency and phase relationships of two input signals. The frequency relationship of the two input signals determines the pattern seen. The pattern will be stable only if a common divisor exists between the two frequencies.*

## TV SIGNAL DISPLAYS

### Displaying a TV Line-rate Signal

1. Perform the steps and set the controls as outlined under Baseline Trace and Signal Display to obtain a basic display of the desired TV signal.
2. Set A SEC/DIV to 10  $\mu$ s, and A & B INT to CH 1 or CH 2 as appropriate for applied signal.
3. Set A TRIGGER SLOPE for a positive-going signal (lever up) if the applied TV signal sync pulses are positive-going, or for a negative-going signal (lever down) if the TV sync pulses are negative-going.

4. Adjust the A TRIGGER LEVER control for a stable display, and AUTO INTENSITY for desired display brightness. If necessary, adjust VERTICAL VOLTS/DIV control to obtain 5 divisions or greater amplitude for a stable display.

### Displaying a TV Field-rate Signal

1. Perform Step 1 under Displaying a TV Line-rate Signal.
2. Set A SEC/DIV to 2 ms, A TRIGGER MODE to TV FIELD and A & B INT to CH 1 or CH 2 as appropriate for the applied signal.
3. Perform Step 3 and 4 under Displaying a TV Line-rate Signal.
4. To display either Field 1 or Field 2 individually at faster sweep rates (displays of less than one full field), set VERTICAL MODE to BOTH and ALT simultaneously. This synchronizes the Channel 1 display to one field and the Channel 2 display to the other field.

To change the field that is displayed, interrupt the triggering by repeatedly setting the AC GND DC switch to GND or disconnecting the signal from the applied signal input until the other field is displayed. To display both fields simultaneously, apply the input signal to both the CH 1 and CH 2 inputs via two probes, two cables, or through a dual-input coupler.

To examine either a TV Field-rate or Line-rate signal in more detail, either the X10 Magnifier or HORIZONTAL MODE functions may be employed as described for other signals elsewhere in this manual.

5. To display a selected horizontal line, first trigger the sweep on a vertical (field-rate) sync pulse, then use the delayed sweep to delay out to that line for close examination. This procedure is useful for examining VITS signals.

# THEORY OF OPERATION

## INTRODUCTION

### SECTION ORGANIZATION

This section contains a functional description of the 2215 Oscilloscope circuitry. The discussion begins with a general summary of instrument functions followed by a detailed description of each major circuit. Functional block diagrams and schematic diagrams are used to show the interconnections between parts of the circuitry, to indicate circuit components, and to identify interrelationships with the front-panel controls.

Schematic diagrams and the overall block diagram are located in the tabbed "Diagrams" section at the back of this manual. The schematic diagram associated with each description is identified in the text and indicated on the tab of the appropriate foldout page by a numbered diamond symbol. For best understanding of the circuit being described, refer to both the appropriate schematic diagram and the functional block diagram.

### INTEGRATED CIRCUIT DESCRIPTIONS

#### Digital Logic Conventions

Digital logic circuits perform many functions within the instrument. Functions and operation of the logic circuits are represented by logic symbology and terminology. Most logic functions are described using the positive-logic convention. Positive logic is a system of notation whereby the more positive of two levels is the TRUE (or 1) state; the more negative level is the FALSE (or 0) state. In this logic description the TRUE state is referred to as HI, and the FALSE state is referred to as LO. The specific voltages which constitute a HI or a LO state vary between specific devices. For specific device characteristics, refer to the manufacturer's data book.

#### Linear Devices

The functioning of individual linear integrated circuit devices in this section use waveforms or other techniques such as voltage measurement and simplified diagrams to illustrate their operation.

## GENERAL DESCRIPTION

In the following overall functional description of the 2215 Oscilloscope, refer to the basic block diagram (Figure 3-1) and to the detailed block diagram (Figure 9-4) located in the "Diagrams" section of this manual. In Figures 3-1 and 9-4, the numbered diamond symbol in each major block refers to the appropriate schematic diagram number.

Signals to be displayed on the crt are applied to either the CH 1 OR X input connector or the CH 2 OR Y input connector. The signals may be coupled to the attenuator circuit either directly (DC) or through an input-coupling capacitor (AC). The input may also be disconnected and the input to the attenuators grounded when the GND position of the coupling switch is used. In the GND position, the ac-coupling capacitor is allowed to precharge to the dc level present at the input connector. This precharging prevents large trace shifts of the display when switching from GND to AC coupling.

Each channel output signal from the Attenuator circuitry is applied to the Vertical Preamplifier circuitry for further amplification. The Channel 2 Preamplifier includes an Invert feature that allows the operator to invert the Channel 2 signal display on the cathode-ray tube (crt). Trigger Pickoff Amplifiers in each channel supply an internal trigger signal from either channel signal or from both channels to the Internal Trigger Amplifier in the Trigger circuitry.

Each channel signal is selected for display in turn by the Channel Switching Logic circuit under control of the front-panel VERTICAL MODE switches. The output signal from the Channel Switching Logic circuit is applied to a Diode Gate circuit. The Diode Gate circuit switches either channel signal (or both signals for ADD) to a Delay Line Driver stage that supplies the proper drive and impedance match to the Delay Line. The Delay Line produces approximately 100 ns of delay in the vertical signal to allow the Horizontal circuitry time to produce the necessary sweep to display the signal.

Final amplification of the vertical signal is supplied by the Vertical Output Amplifier. The Vertical Output Amplifier supplies the required signal levels necessary to produce vertical deflection of the electron beam in the crt.

The A/B Sweep Separation circuitry supplies a dc-offset current to the Vertical Output signal which is used to

vertically position the B trace with respect to the A trace when ALT HORIZONTAL MODE is selected.

The Trigger circuitry uses either the Internal Trigger signal derived from the input signal(s), an External Trigger signal, or a Line Trigger signal obtained from the ac-power-source input waveform to develop the triggering signal for the Sweep Generator. An Auto Trigger circuit ensures that the range of the A TRIGGER LEVEL control conforms approximately to the peak-to-peak amplitude of the trigger signal when either AUTO or TV FIELD TRIGGER MODE is selected. In NORM MODE, the A TRIGGER LEVEL control must be adjusted for the correct trigger signal level before a sweep can be generated.

A TV Field sync circuit provides stable triggering on television-signal vertical-sync pulses. Triggering at the television line rate is accomplished when either AUTO or NORM MODE is used.

The Sweep Logic circuit controls the generation of the sweep and the unblanking of the Z-Axis Amplifier for the A Sweep display. When the A TRIGGER MODE switch is set to either AUTO or TV FIELD and no trigger signal is present, the Auto Baseline circuit causes the Sweep Logic circuit to produce a sweep after a period of time. In the NORM position of the A TRIGGER MODE switch the Auto Baseline circuit is disabled, and a sweep will not be generated until a triggering signal is received.

A gate signal produced by the A Sweep Logic circuit is applied to the A Miller Sweep circuit. This circuit produces a linear sweep output with a run-up time that is controlled by the A SEC/DIV switch. The sweep signal is applied to the Horizontal Preamplifier for initial amplification. Final amplification of the sweep signal to drive the crt horizontal deflection plates is provided by the Horizontal Output Amplifier.

The Horizontal Preamplifier gain is increased by a factor of 10 when the X10 Magnifier feature is used. Horizontal positioning of the display is also accomplished in the Horizontal Preamplifier circuit.

In the X-Y Mode of operation the CH 1 signal, via the Internal Trigger circuitry, is applied to the XY Amplifier where it is amplified for application to the Horizontal Preamplifier. In this operating mode, the CH 1 Internal

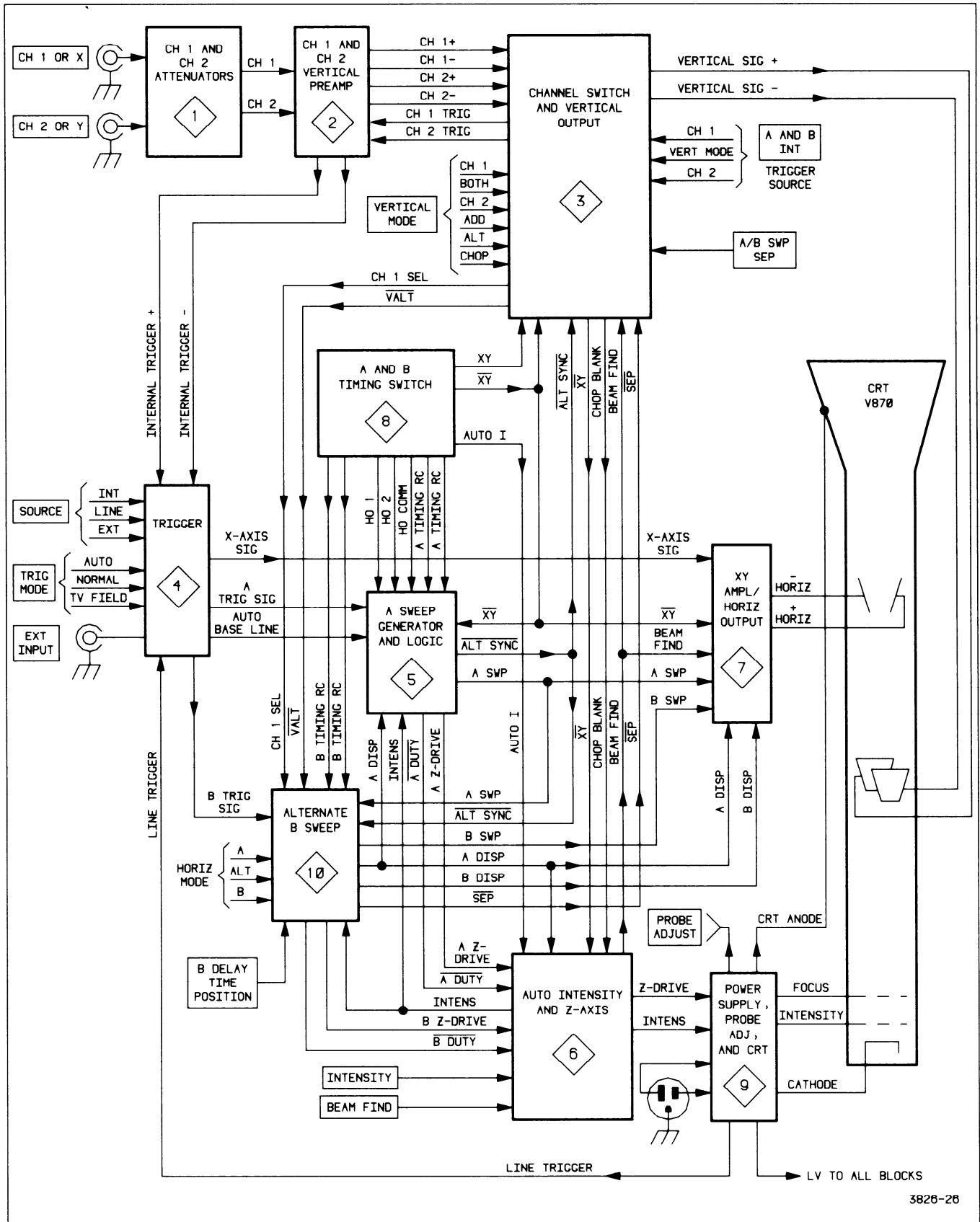

Figure 3-1. Basic block diagram of the 2215 Oscilloscope.

3826-26



Trigger signal supplies the horizontal deflection to the crt, and a sweep signal is not produced by the Miller Sweep circuit.

The ALT HORIZONTAL MODE and the B HORIZONTAL MODE displays are controlled by circuitry contained in the Alternate B Sweep circuit. The circuit includes the B Miller Sweep Generator and the B Sweep Logic circuitry. In addition to providing the B Sweep sawtooth waveform, control signals are generated to control the display switching between the A display and the B display and to control the B Z-Drive signal for the alternated A Intensified Sweep and the B Sweep.

The Z-Axis drive from both the A Sweep Logic circuit and the Alternate B Sweep circuit is applied to the Z-Axis amplifier. The output signal from the Z-Axis Amplifier circuit sets the crt intensity. A Chop Blanking signal from the Chop Oscillator circuit blanks the crt display during the transition between the vertical channels when using CHOP VERTICAL MODE.

The DC Restoration circuit raises the output level of the Z-Axis Amplifier to allow it to be coupled to the crt control grid. Direct coupling is not employed due to the amplitude of the voltage levels applied to the crt elements.

The A Duty and the B Duty signals from the A Sweep Logic and Alternate B Sweep circuits are applied to the Auto Intensity circuit. The Auto Intensity circuit provides partial control of the intensity of the display when switching between different positions of the SEC/DIV switches.

The Power Supply provides all the necessary operating voltages for the instrument circuitry. Operating potentials are obtained from a circuit composed of the Preregulator, Inverter and Transformer, and Rectifiers and Filters. The Preregulator produces approximately +45 V from the ac-power-input source which is used to drive the 20-kHz Inverter stage. The Transformer secondary windings provide various ac levels that are rectified and filtered to produce the operating voltages. A High-voltage Multiplier circuit produces the accelerating, focus, and cathode potentials required by the crt.

A front-panel PROBE ADJUST output is provided for use in adjusting probe compensation. The voltage at the PROBE ADJUST connector is a negative-going square wave that has a peak-to-peak amplitude of approximately 0.5 V and a repetition rate of approximately 1 kHz.

# DETAILED CIRCUIT DESCRIPTION

## VERTICAL ATTENUATORS

Both the Channel 1 and Channel 2 Attenuator circuits, shown in Diagram 1, are identical in operation. In the following discussion, only the Channel 1 Attenuator circuit is described. The matching components in the Channel 2 Attenuator circuit perform the same function.

The Attenuator circuit (see Figure 3-2) provides control of input coupling, vertical deflection factor, and variable volts-per-division balance. Input signals for crt vertical deflection may be connected to either or both the CH 1 OR X and the CH 2 OR Y input connectors. In the X-Y Mode of operation, the signal applied to the CH 1 OR X connector provides horizontal (X-Axis) deflection for the display, and the signal applied to the CH 2 OR Y connector provides the vertical (Y-Axis) deflection for the display.

### Input Coupling

The signal applied to the CH 1 OR X input connector can be ac-coupled, dc-coupled, or internally disconnected from the input of the High-Z Input Attenuator circuit. Signals applied to the CH 1 input connector are routed through resistor R101 to Input Coupling switch S101. When S101 is set for dc coupling, the CH 1 signal is applied directly to the input of the High-Z Attenuator stage. When ac-coupled, the input signal passes through R100 and dc-blocking capacitor C102. The blocking capacitor prevents the dc component of the input signal from being applied to the Attenuator circuit. When S101 is set to GND, the direct signal path is opened and the input of the attenuator is connected to ground. This provides a ground reference without the need to disconnect the applied signal from the input connector. The coupling capacitor is allowed to precharge through R102, a high-resistance component, which is connected across Input Coupling switch S101 in the GND position.

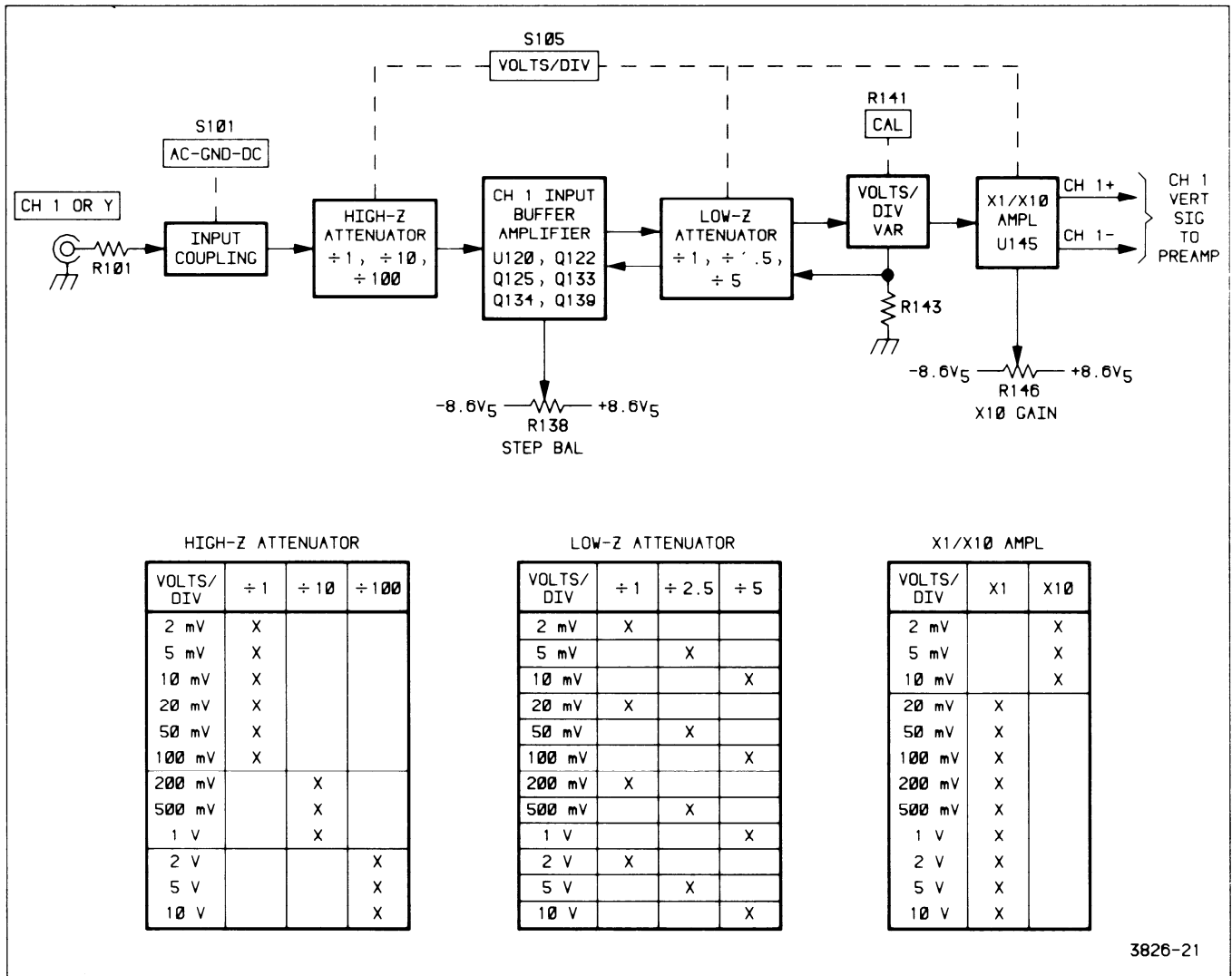

Figure 3-2. Detailed block diagram of the Channel 1 attenuator and attenuator switching tables.

### High-Z Attenuator

The first section of attenuator switch S105A directs the input signal to one of three paths: directly through R103 (no attenuation); through a 10X attenuator consisting of C105, C107, R105, R106, R107, and R108; or through a 100X attenuator consisting of C111, C112, R110, R111, R112, R114, and R115. Medium-frequency normalization of the input capacitance is accomplished by C104 in the 10X attenuator and by C110 in the 100X attenuator. Switch S105B connects the appropriate attenuator output to the input of the Buffer Amplifier.

### Buffer Amplifier and Low-Z Attenuator

The Buffer Amplifier presents a high-impedance, low-capacitance load to the input signal and delivers an accurate replica of that signal to a low-impedance buffer output circuit. The Low-Z output circuit is composed of a 250-Ω

voltage-divider network (R139F through R139J) and the Volts/Div Var circuit (R141, C141, and R143). Switch S105B selects the appropriate output from the voltage divider. The Buffer Amplifier contains two paths: a slow path consisting of R116, R117, U120, and R119 in parallel with C119; and a fast path through C121. The signals through both paths are applied to the gate of Q122.

In the slow-path portion, the input signal is divided by ten by the combination of R117 and R116 and is then applied to U120 pin 3. The Buffer Amplifier output signal is also divided by ten by the combination of R139B, R139C, R139D, and R139N. Sufficient dc-gate bias for input FET Q122 is generated by the slow-path circuit to produce a null (zero difference) between pins 2 and 3 of U120. The closed-loop gain of the slow path is matched to the fast-path gain. If the average output voltage from the

fast path changes, transconductance amplifier U120 adjusts the dc gate bias on Q122 to keep U120 pin 2 and U120 pin 3 nulled. This action keeps the slow-path and the fast-path gains matched. Resistor R119 isolates the output impedance of U120 from the input of FET Q122. This isolation, in combination with the high input impedance of U120, prevents high-frequency loading of the input signal. Capacitor C119 compensates for the output capacitance of U120.

Step Balance potentiometer R138 (at pin 1 of R139) is adjusted to compensate for input offsets reaching U120 pins 2 and 3 when switching between VOLTS/DIV switch positions.

In the fast path, the input signal is ac-coupled to input FET Q122 through C121. The input FET is arranged in a source-follower configuration used to drive complementary emitter followers Q133 and Q134. The combination of Q125, R126, R131, R132, VR130, and R130 sets a constant current through R125 in the source lead of Q122. The voltage drop across R125 biases Q133 and Q134 for about a 10-mA idle current.

A bootstrap circuit composed of Q139, VR122, and R122 connects the Q122 drain to the Q122 source. This circuit forces the bias voltage across Q122 to remain constant, which in conjunction with the constant bias current supplied by R125, keeps Q122 operating at a constant power level to prevent distortion due to changing signal currents.

Complementary emitter followers Q133 and Q134 supply drive current to the  $\div 1$ ,  $\div 2.5$ , and  $\div 5$  voltage dividers and provide impedance matching between input FET Q122 and the divider network. The bias levels of Q133 and Q134 are stabilized by emitter resistors R139A and R139E respectively. Average voltage changes occurring in the output of Q133 and Q134 are sensed through R139B and R139D which are connected to the point of lowest impedance (the emitters of Q133 and Q134). Resistor R139C provides a path that completes the feedback loop to the slow-path portion of the Buffer Amplifier.

### Volts/Div Var Circuit and X1/X10 Amplifier

The appropriate voltage divider signal output ( $\div 1$ ,  $\div 2.5$ , or  $\div 5$ ) is selected by VOLTS/DIV switch S105B and routed to the Volts/Div Var circuit composed of C141, R141, and R143. Changes that occur in the Buffer Amplifier output impedance due to setting R141 or switching the divider output are sensed via R139M. These changes modify the slow-path feedback signal to cause U120 to again match the gain of both paths.

From the Volts/Div Var circuit, the signal is applied to the input of the X1/X10 Switchable-gain Amplifier U145. Amplifier U145 produces a differential output signal from the single-ended input signal. The gain of the amplifier is controlled by the setting of VOLTS/DIV switch S105.

Amplifier gain is changed by switching between two pairs of transistor amplifiers contained in U145. Gain of the X10 amplifier pair is adjusted by R145 to obtain the correct deflection factor for the 2m, 5m, and 10m VOLTS/DIV switch positions. Resistors R146, R147, and R148 act to balance any dc offsets between the X1 and X10 amplifiers. Trace shift occurring when the VOLTS/DIV Variable control is rotated is minimized by resistor R142 which stabilizes the input bias current to U145.

## VERTICAL PREAMPS

The Channel 1 and Channel 2 Preamp circuitry, shown in Diagram 2, includes the vertical preamplifiers, the internal trigger pickoff amplifiers, and a common-base output stage for each channel. Vertical positioning of the channel display is incorporated in the common-base amplifier stage.

### Channel 1 Vertical Preamp

The Channel 1 Vertical Preamp produces differential output signals to drive the Vertical Output Amplifier and internal trigger signals to drive the Trigger circuitry.

Differential signal current from the Attenuator circuitry is applied to common-base transistors Q157 and Q167 through cable-terminating resistors R151 and R161 respectively. The collector currents of Q157 and Q167 will flow through R158 and R168 to produce level-shifted signals which drive U170D and U170E. Balance potentiometer R154 is adjusted to balance the dc level of the Channel 1 output with the Channel 2 output by setting the bias levels of Q157 and Q167. Channel 1 frequency response is matched to Channel 2 response by adjusting C167.

Transistors U170D and U170E form a common-emitter amplifier. The gain of U170D and U170E is set by R180 (connected between the emitters), and the high-frequency response is compensated by C180. The emitters are also connected to the bases of U170C and U170B respectively to provide an internal trigger signal pickoff point. Vertical signal output current flows from the collectors of U170D and U170E to the emitters of common-base amplifiers Q177 and Q187. A shunt resistor gain network (R176 and R186) sets the gain of the common-base stage. Channel 1 POSITION control R190 supplies a variable offset current to the emitters of Q177 and Q187 which allows the trace

to be vertically positioned on the crt. The common-base amplifier stage converts the differential signal input current to a differential signal output voltage that is applied to the Diode Gate circuitry (Diagram 3).

### Channel 2 Vertical Preamplifier

The Channel 2 Vertical Preamplifier functions the same as the Channel 1 Vertical Preamplifier previously described, with the exception of an additional pair of transistors that performs the inverting function. In the Normal mode of operation, Q257 and Q267 are biased on and Q258 and Q268 biased off by INVERT switch S264 grounding one end of R263. In the Invert mode (INVERT switch pressed in), cross-wired transistors Q258 and Q268 are biased on and Q257 and Q267 biased off by grounding the junction of R256 and R266. Invert Bal potentiometer R264 is adjusted to correct for dc offsets between the two switching-transistor pairs. When R264 is correctly adjusted, a baseline trace will maintain the same vertical position as the amplifier is switched between Invert and Normal.

### Internal Trigger Pickoff Amplifier

The Internal Trigger Pickoff Amplifier supplies trigger signals to the Internal Trigger Amplifier in the Trigger circuitry (Diagram 4). Internal trigger signals are provided by the vertical preamplifiers and are applied to the bases of U170B and U170C (for Channel 1) and U270B and U270C (for Channel 2). These transistor pairs are biased on, either individually or together, from the Internal Trigger Switching Logic circuit (Diagram 3).

When Channel 1 is the selected internal trigger source, Q173 and U170A (CH 1) will be biased on and Q273 (CH 2) biased off. Current flowing through R173, R183, and R197 will bias on U197A to keep U197E cut off. Emitter current is supplied to U170A by U197D. In turn, U170A then supplies emitter current to U170B and U170C to enable the Channel 1 internal trigger signals to pass to the Internal Trigger Amplifier.

When Channel 2 is selected as the internal trigger source, Q273 and U270A will be biased on and Q173 biased off. Transistor U197A will remain on, and current supplied by U197D will supply emitter current to U270A. Then U270A in turn supplies the emitter current to U270B and U270C and enables the Channel 2 internal trigger signals to pass to the Internal Trigger Amplifier.

The actual signal source selected when the A TRIGGER A & B INT switch is set to VERT MODE depends on the setting of the VERTICAL MODE switches. If either CH 1 or CH 2 VERTICAL MODE is selected, the preceding discussion on Channel 1 or Channel 2 internal trigger signals applies. When the VERTICAL MODE switch is set

to BOTH, the VERTICAL MODE ADD-ALT-CHOP switch setting determines the switching action for selecting the internal trigger source.

Selecting ADD VERTICAL MODE causes both internal trigger-select signals (CH 1 Trig and CH 2 Trig) to be LO, and both Q173 and Q273 are biased off. Transistor U197A then becomes biased off causing U197E to saturate. With U197E saturated, emitter current is supplied to both Channel 1 and Channel 2 Trigger Pickoff Amplifiers (U170C and U170B for Channel 1 and U270B and U270C for Channel 2) via R196-CR196 and R296-CR296 respectively. When both pickoff amplifiers are enabled, the resulting trigger signal is the sum of the Channel 1 and Channel 2 internal trigger signals. The sum of the current supplied by U197E to both pickoff amplifiers is the same magnitude as the current from U197D when either CH 1 or CH 2 is selected individually. Therefore, the dc output to the Internal Trigger Amplifier will be the same for CH 1, CH 2, and ADD VERTICAL MODE trigger signals.

When ALT VERTICAL MODE is selected with the previously established settings (VERTICAL MODE to BOTH, A & B INT to VERT MODE, and A SOURCE to INT), the internal trigger-select signals alternate between channels. On one sweep the Channel 1 internal trigger will be selected as previously described. On the alternate sweep, Channel 2 internal trigger will be selected, again as previously described.

Under the same switch-setting conditions, selecting CHOP VERTICAL MODE produces the same trigger-selection conditions as described for ADD VERTICAL MODE. The sum of the Channel 1 and Channel 2 internal trigger signals will be passed to the Internal Trigger Amplifier. See the "Internal Trigger Switching Logic" discussion for a description of how the internal trigger selection signals are generated.

## CHANNEL SWITCH AND VERTICAL OUTPUT

The Channel Switch circuitry, shown on Diagram 3, selects the input signal or combination of input signals to be connected to the Vertical Output Amplifier. By setting the logic input into the Channel Switching Logic circuit, VERTICAL MODE switches S315 and S317 select the input signal combinations to be displayed. The internal trigger-select signals are also generated in the Channel Switch circuitry.

### Diode Gates

The Diode Gates, consisting of eight diodes, act as switches that are controlled by the Channel Switching

**Theory of Operation—2215 Service**

Logic circuitry. The Q- and  $\bar{Q}$ -outputs of U317A (pins 5 and 6 respectively) control forward biasing of the diodes to turn the gates on and off.

**CHANNEL 1 DISPLAY ONLY.** To display only the Channel 1 signal, the CH 1 Enable signal (U317A pin 5) is HI and the CH 2 Enable signal (U317A pin 6) is LO.

With CH 1 Enable HI, gate diodes CR187 and CR177 are reverse biased (see Figure 3-3). Series gate diodes CR188 and CR178 are forward biased, and the Channel 1 vertical signal is allowed to pass to the Delay Line Driver. A LO CH 2 Enable signal applied to the Channel 2 gate diodes forward biases CR287 and CR277, and the Channel 2 vertical-signal current is shunted away from series diodes CR288 and CR278. The Channel 2 series diodes are reverse biased, and the Channel 2 signal current is prevented from reaching the Delay Line Driver.

**CHANNEL 2 DISPLAY ONLY.** When CH 2 VERTICAL MODE is selected, the CH 1 Enable signal goes LO and the

CH 2 Enable signal goes HI. The Channel 1 signal is blocked, and the Channel 2 signal reaches the Delay Line Driver.

**ADD DISPLAY.** Both Diode Gates are biased on to pass the Channel 1 and Channel 2 vertical signals. The channel signal currents are summed at the input to the Delay Line Driver. The Add Enable signal supplies the extra current required to keep both Diode Gates forward biased and to maintain the proper dc level at the base of the Delay Line Driver input transistors (Q331 and Q341).

**ALTERNATE AND CHOPPED DISPLAY.** The Diode Gates are switched on and off by the Channel Enable signals from the Channel Switching Logic circuit. When ALT VERTICAL MODE is selected, the Diode Gates are switched at the end of each trace. For CHOP VERTICAL MODE, the gates are switched at a rate of about 250 kHz.

**X-Y DISPLAY.** Setting the A SEC/DIV switch to the X-Y position activates the X-Y display feature. The

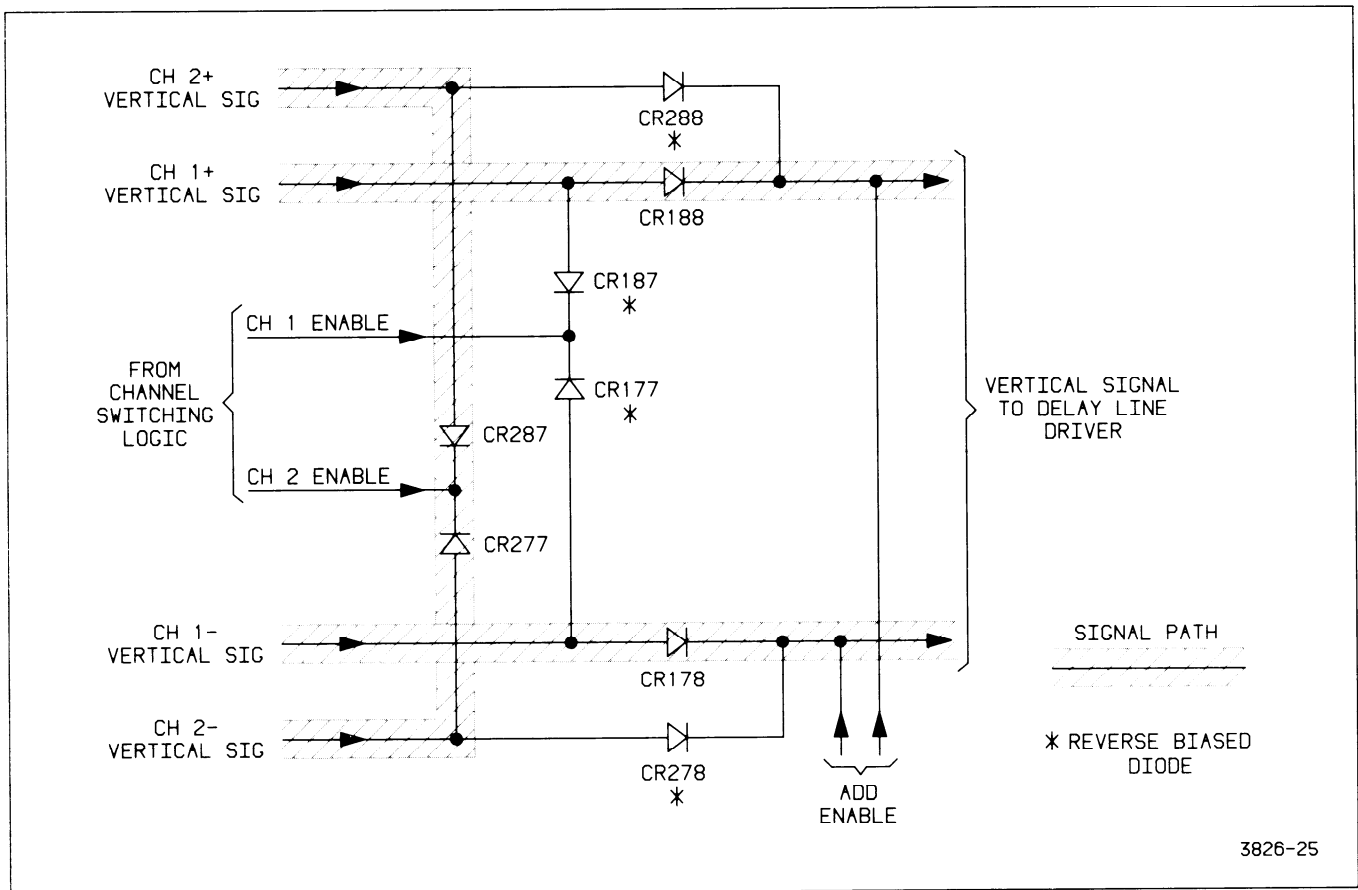

Figure 3-3. Diode gate biasing for a Channel 1 display.

Channel 1 Diode Gate is held off, and the Channel 2 Diode Gate is biased on. The Channel 2 signal is passed to the Delay Line Driver and ultimately to the crt to provide the Y-Axis display deflection. The X-Axis deflection signal is supplied to the XY Amplifier (Diagram 7) from the Channel 1 signal via the Internal Trigger Amplifier (Diagram 4).

### Delay Line Driver

The Delay Line Driver converts the signal current from the Diode Gates into a signal voltage for application to the Delay Line. The Delay Line Driver is configured as a differential shunt feedback amplifier and is composed of Q331, Q335, Q341, and Q345. Input currents to common-emitter transistors Q331 and Q341 are converted to voltages at the bases of Q335 and Q345 respectively. Emitter-follower output transistors Q335 and Q345 then drive the Delay Line through reverse terminations R335-C335 and R345-C345. Amplifier compensation is provided by R340 and C340, and shunt feedback is supplied by R336 and R345.

### Delay Line

Delay Line DL350 provides about 100 ns of delay in the vertical signal. When using internal triggering (CH 1, CH 2, or VERT MODE), the delay time allows the Sweep Generator sufficient time to produce a sweep before the vertical signal reaches the crt deflection plates. This feature permits viewing the leading edge of the internal signal that originates the trigger pulse.

### Vertical Output Amplifier

The Vertical Output Amplifier, also shown on Diagram 3, provides final amplification of the input signals for application to the deflection plates of the crt. Signals from the Delay Line are applied to a differential amplifier input stage composed of Q350 and Q360. The Delay Line is terminated in the proper impedance by resistors R338 and R348. Resistor R355 sets the gain of Q350 and Q360. Thermal compensation of the stage gain is provided by thermistor RT356, connected in series with R356 across R355. The RC networks connected across R355 provide both low- and high-frequency compensation of the stage.

The differential output is applied to output transistor pairs Q376-Q377 and Q386-Q387. These transistors form a common-emitter shunt-feedback amplifier stage, with R376, R377, R386, and R387 serving as feedback elements. Capacitors C377 and C387, connected across R377 and R387 respectively, provide increasing negative feedback as the signal frequency rises to limit the amplifier bandwidth at the upper frequency limit. Output voltage from the amplifier is divided between the two transistors of each half. The signal voltage applied to the crt vertical deflection

plates is the sum of voltage drops across the pairs (Q376-Q377 and Q386-Q387). The deflection voltage is proportional to the signal current driving the bases of Q376 and Q386.

BEAM FIND switch S390 (Diagram 6) normally supplies  $-8.6$  V directly to R390 to set the stage bias. When the BEAM FIND button is pressed in and held, the direct voltage is removed and the  $-8.6$ -V bias is provided via series resistor R391. The output voltage swing is thereby reduced to hold the vertical trace deflection to within the graticule area.

### A/B Sweep Separation Circuit

The circuit composed of Q370, Q380, Q392, and associated components provides a means of vertically positioning the B trace with respect to the A trace during ALT HORIZONTAL MODE displays. The  $\overline{\text{Sep}}$  signal, provided by the Alternate Display Switching circuitry (Diagram 10), supplies the biasing voltage for Q392. During the B trace display portion of the Alternate Horizontal display,  $\overline{\text{Sep}}$  is LO and Q392 is biased off. This action allows A/B SWP SEP potentiometer R395 to affect the bias on one side of a differential amplifier composed of Q380 and Q370. The differential amplifier supplies a dc offset current to the Vertical Output signal that changes the position of the B trace on the crt face.

During the A trace portion of the Alternate Horizontal display,  $\overline{\text{Sep}}$  is HI and Q392 is biased on. The base voltage on Q380 then equals the base voltage on Q370. With equal base voltages, the differential amplifier supplies equal current to both sides of the Vertical Output signal and no offset to the A trace occurs.

### Channel Switching Logic Circuit

The Channel Switching Logic circuitry composed of U310A and U317A selects either Channel 1 or Channel 2 and various display modes for crt display via front-panel switches and the X-Y position of the A SEC/DIV switch.

When the instrument is not in the X-Y Mode, signal line XY is grounded through contacts on the A SEC/DIV switch (Diagram 8). This action establishes LO logic levels on pins C, B, and G of front-panel switch S317 (CH 1-BOTH-CH 2) and on pins C and B of S305 (A & B INT).

Switch S317 selects the vertical channel signal that drives the Delay Line Driver via the Channel Diode Gates. With S317 set to CH 1, a LO is applied to the Set input (pin 4) of U317A. Flip-flop U317A will then be set, and the Q output (pin 5) will be HI. Pin 5 of U317A is the CH 1 Enable signal line, and when it is HI, the Channel 1 vertical

signal is gated to the Delay Line Driver. When S317 is set to CH 2, the Reset input of U317A (pin 1) will be held LO through CR705. The CH 2 Enable signal (U317A, pin 5) is then set HI and the Channel 2 vertical signal is gated to the Delay Line Driver.

Setting S317 to the BOTH position removes the LO from both the Set and Reset inputs of U317A. This action allows the channel selected for display to be determined either by the logic level applied to the D input (pin 2) and the clock applied to pin 3 or by the logic level applied to the Set and Reset inputs from the ADD-ALT-CHOP switch.

The ADD-ALT-CHOP switch (S315) is enabled by the LO placed on pins A, C, and F when the CH 1-BOTH-CH 2 switch is set to BOTH. When in ADD, S315 holds both the Set and Reset input of U317A LO through CR706 and CR701 respectively. The Q and  $\overline{Q}$  outputs of U317A will then be HI, and both Channel 1 and Channel 2 vertical signals are gated to the Delay Line Driver. The signal current is summed at the input to the Delay Line Driver, and the resulting oscilloscope Add vertical display is the algebraic sum of the two vertical signals.

The Add Enable circuit, composed of Q316, U197C, and U315A, is activated when both Diode Gates are turned on for an Add vertical display. With the Q and  $\overline{Q}$  outputs of U317A HI, the output of U315A will be LO and transistor Q316 is biased on. The collector of Q316 rises toward +5 V and U197C is biased on. Transistor U197C supplies the additional current required to keep both Diode Gates forward biased and to supply the proper dc level to the Delay Line Driver input. Bypass capacitor C316 prevents switching transients from being introduced into the Delay Line Driver by the Add Enable circuit.

When S315 is set to ALT, a HI is placed on both the Set and Reset inputs of U317A. Flip-flop U317A will transfer the logic level on the D input (pin 2) to the Q output (pin 5) on each clock-pulse rising edge. Pin 1 of NAND-gate U310A is held HI by the Chop Oscillator output, and pin 2 follows the  $\overline{\text{Alt Sync}}$  signal produced by the Holdoff circuitry in the A Sweep Generator (Diagram 5). The output of U310A (pin 3) is therefore an inverted  $\overline{\text{Alt Sync}}$  pulse. The signal on the D input of U317A (pin 2) follows the logic level set by the  $\overline{Q}$  output pin. As each clock pulse occurs, the states of the Q and  $\overline{Q}$  outputs reverse (toggle), enabling Channel 1 and Channel 2 Diode Gates alternately with each sweep.

**CHOP OSCILLATOR.** Setting S315 to CHOP enables the Chop Oscillator and the Chop Blanking circuit. Pins C and D of S315 are connected to place a LO logic level on

the Set input (pin 10) of U317B. The Q output of U317B is set HI and the Chop Oscillator is allowed to run. A HI level is present on U310D pin 13 due to C308 being charged to the HI level on U310D pin 11. When pin 12 of U310D also goes HI, the output of U310D goes LO. Capacitor C308 now must discharge to the new dc level. As soon as the charge of C308 reaches the LO threshold level of U310D, the output at pin 11 switches HI again and C308 charges toward the HI logic level (see Figure 3-4).

When the HI switching threshold level is reached, the output of U301D changes states to LO again. This cycle continues at about 500 kHz to produce both the Chop Clock and the Chop Blank signals.

The Chop signal is gated through NAND-gate U310C and applied to U310A pin 1. The  $\overline{\text{Alt Sync}}$  pulse on U310A pin 2 is HI (except during holdoff time) so the output of U310A pin 3 is the inverted Chop Oscillator signal on pin 1. This signal is applied to the Clock Input (pin 3) of U317A to drive the Channel Switching circuitry. Since flip-flop U317A clocks with rising edges only, the frequency of the chopped channel switching is about 250 kHz.

The signal output from U310C pin 8 is also fed to the Chop Blanking circuit. Capacitor C311 and resistors R310 and R311 form a differentiating circuit that produces positive and negative short-duration pulses when the Chop Oscillator signal changes levels.

The dc level at U310B pins 4 and 5 is set slightly above the HI switching threshold logic by a voltage divider consisting of R310 and R311. Positive pulses from C311 continue to hold U310B above the threshold level, so the output remains LO. Negative pulses from C311 drop below the threshold level of U310B, and the output of U310B switches HI for a duration of about 0.4  $\mu\text{s}$  (see Figure 3-4) to produce the positive Chop Blanking pulse. The Chop Blanking pulse is fed to the Z-Axis Amplifier and is used to prevent display of the transistions when switching between vertical channels.

### Internal Trigger Switching Logic

Internal trigger-selection signals to the Trigger Pickoff Amplifier (Diagram 2) are produced in a logic circuit composed of U305B, U305C, U305D, U315B, and U315C. The A & B INT Trigger Source switch (S305), in conjunction with CH 1-BOTH-CH 2 switch (S317), determines the internal trigger source selected. When either the CH 1 or CH 2 Internal Trigger signal is selected by S305, the selected channel will be the internal trigger source. When VERT MODE is selected as the internal trigger signal, the position of S317 determines the channel(s) selected as the internal trigger source.

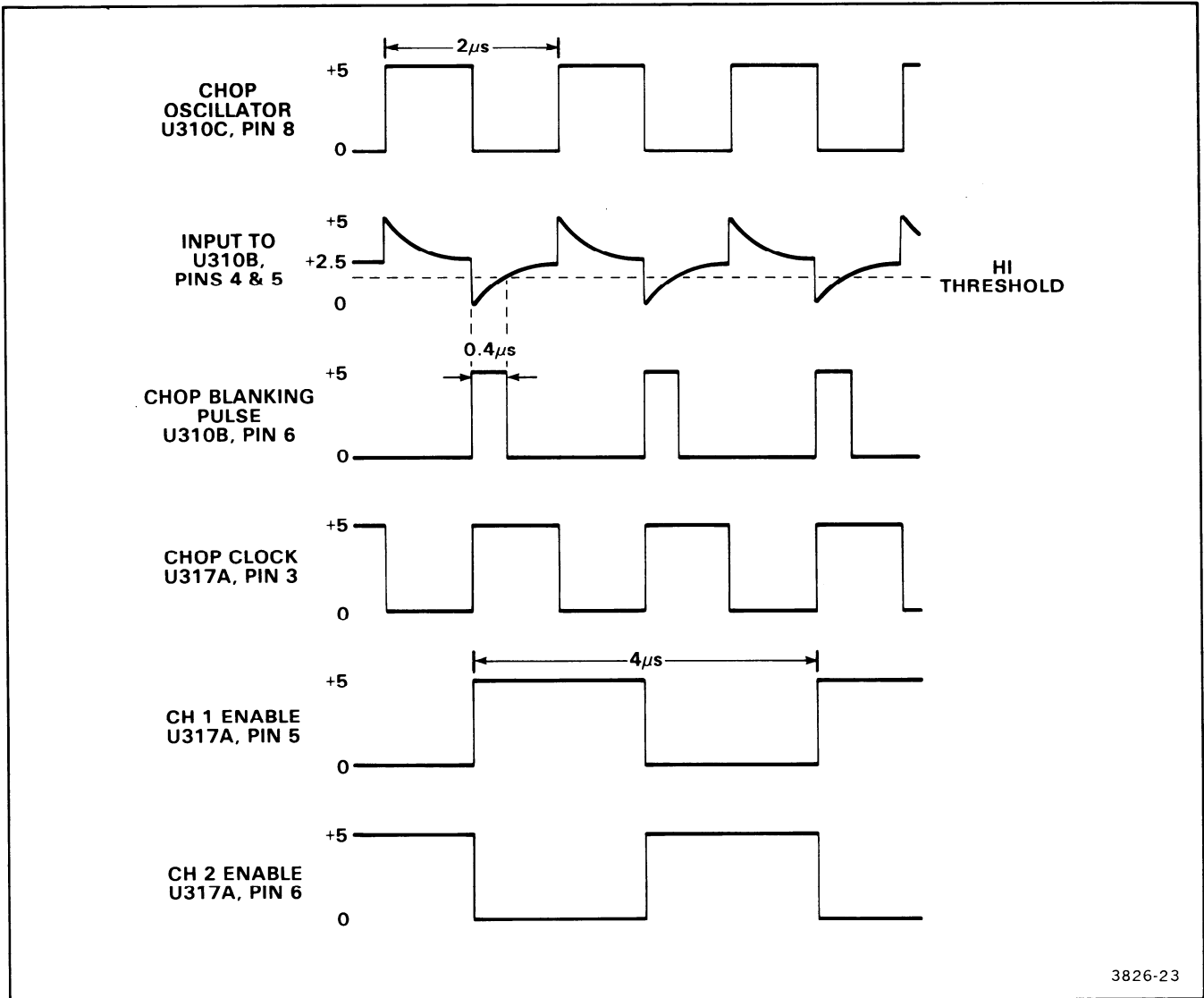

3826-23

Figure 3-4. CHOP VERTICAL MODE waveforms.

**CHANNEL 1 SOURCE.** The XY signal line from the A SEC/DIV switch (S630B) applies a LO logic level to A & B INT switch S305 on pins B and C. In the CH 1 position, the LO is coupled from pin C to pin D and applied to U305B pin 4.

The LO is gated through U305B and applied to the  $\overline{\text{CH 1}}$  Trig signal line in a wired-AND connection. The LO from U305B is applied to Q273 in the Channel 2 Internal Trigger Pickoff Amplifier (Diagram 2) to bias it off, thus preventing the Channel 2 signal from being selected. Operation of the Internal Trigger Pickoff Amplifiers is discussed in the "Channel 1 and Channel 2 Preamps" circuit descriptions.

Concurrently, pins 9 and 10 of U305C are pulled HI through R304 and R300 respectively to place a HI at U305C pin 8. The HI from U305C to the wired-AND connection on the  $\overline{\text{CH 2}}$  Trig signal line enables the output of U315B to control the logic level of the  $\overline{\text{CH 2}}$  Trig signal. Control is accomplished by the logic levels on the inputs of U305D, pins 12 and 13.

The LO on U305B pin 4 (placed there by S305) also occurs on U305D pin 13. This ensures a LO at U305D pin 11, which is applied to U315C pin 9 and to U315B pin 5. The logic level applied to U315C pin 9 has no effect on the  $\overline{\text{CH 1}}$  Trig signal because a LO is already present at the wired-AND connection to the signal line. However, the



LO applied to U315B pin 5 ensures that the output of U315B is HI. When the CH 2 Trig signal is HI, Q173 in the Channel 1 Internal Trigger Pickoff Amplifier is biased on and the Channel 1 signal is passed to the Internal Trigger Amplifier (Diagram 4).

**CHANNEL 2 SOURCE.** When S305 is set to CH 2, the LO logic level present on S305 pin B is coupled to pin A and applied to U305D pin 12 and to U305C pin 10. The output of U305C at pin 8 is a LO which is applied to the CH 2 Trig signal line by the wired-AND connection. When the CH 2 Trig signal is LO, the Channel 1 Internal Trigger Pickoff Amplifier is biased off to prevent the Channel 1 signal from reaching the Internal Trigger Amplifier.

The inputs to U305B, pins 4 and 5, are both pulled HI through R305 and R304 respectively, and the HI output from pin 6, applied to the wired-AND connection on the CH 1 Trig signal line, allows U315C to control the CH 1 Trig signal logic level. As described in the preceding "Channel 1 Source" discussion, the logic levels at U305D pins 12 and 13 control the output of U315B. The LO on U305D pin 12 ensures a LO output at pin 11, which is applied to U315C at pin 9. This LO ensures a HI output at U315C pin 8, the CH 1 Trig signal line.

With the CH 1 Trig signal HI, Q273 in the Channel 2 Trigger Pickoff Amplifier is biased on and the Channel 2 signal is passed on to the Internal Trigger Amplifier.

**VERT MODE SOURCE.** Additional switch settings are involved in determining the internal trigger signal selection when VERT MODE Trigger Source is selected. Both the CH 1-BOTH-CH 2 and the ADD-ALT-CHOP VERTICAL MODE switches establish the vertical signal display and, as such, must also be used to obtain the internal vertical mode trigger signal.

When S305 is set to VERT MODE, the LO logic level on the XY signal line is removed from both U305B pin 4 and from U305D pins 12 and 13, pulling these inputs HI. In either ADD or ALT VERTICAL MODE, U305C pin 9 and U305B pin 5 are also pulled HI whenever a LO is not being applied from S315.

The input conditions just described for U305B, U305D, and U305C allow the logic levels on U315C pin 10 and U315B pin 4 to control the states of the CH 1 Trig and CH 2 Trig trigger-selection signals. Input signals to pins 10 and 4 are obtained from the Channel Enable signals present at pins 5 and 6 of Channel Switch U317A.

When CH 1 Enable is HI (selecting the Channel 1 signal for display), U315C pin 10 is also HI and U315C pin 8 is LO to disable the Channel 2 Trigger Pickoff Amplifier. Concurrently U317A pin 6 applies a LO to U315B pin 4, and the HI output obtained from U315B pin 6 as a result enables the Channel 1 Trigger Pickoff Amplifier.

For ALT VERTICAL MODE displays, the output states of Channel Switch S317A are switched alternately, at the end of each sweep, in synchronization with the Alt Sync signal. Therefore, on alternate sweeps, the logic levels on U315C pin 10 and on U315B pin 4 also change states.

When the Channel 1 signal is being displayed, the Channel 1 Trigger signal is selected as the internal source. For Channel 2 signal displays, the Channel 2 Trigger signal is selected.

An ADD VERTICAL MODE display causes both pin 5 and pin 6 of U317A to be HI (see "Channel Switching Logic" discussion for a description of the circuit operation). The sum of the two channel vertical signals is displayed, and the sum of the two channel trigger signals is used as the internal trigger signal.

Summation is accomplished by the HI logic levels from U317A pins 5 and 6 causing both the CH 1 Trig and CH 2 Trig signals to go LO. With the input transistors to both Trigger Pickoff Amplifiers biased off, additional circuitry within the Trigger Pickoff amplifiers biases on the pickoff transistors for both Channel 1 and Channel 2 (see the Channel 1 and Channel 2 Preamp circuit descriptions).

A CHOP VERTICAL MODE display also uses the sum of the two internal trigger signals, but the switching logic involved is different from the ADD VERTICAL MODE display. With S315 set to CHOP, a LO logic level is applied to U305B pin 5 and to U305C pin 9 from the XY signal line via contacts on S315, S317, and S305. The outputs of both U305C and U305B are LO and are applied to the wired-AND connection on the CH 1 Trig and CH 2 Trig signal lines. These LO signals override the outputs from U315C and U315B to hold the input transistors of both Channel 1 and Channel 2 Trigger Pickoff Amplifiers biased off. Channel 1 and Channel 2 Trigger signals are summed as described previously for the ADD VERTICAL MODE display.

**X-Y MODE.** When the A SEC/DIV switch is set to X-Y, the Channel 2 signal is selected as the input to the Vertical Output Amplifier to provide the X-Axis deflection. The Channel 1 Trigger signal provides the X-Axis signal to the XY Amplifier (Diagram 7) via the Internal Trigger

Amplifier. Therefore, the Trigger Switching Logic circuit must have inputs that enable the Channel 1 Trigger Pickoff Amplifier.

The LO logic level signal supplied by the XY signal line to S305 and S317 is removed by switching contacts on the A SEC/DIV switch. Concurrently, a LO logic level is placed on the  $\overline{XY}$  signal line by contacts on the A SEC/DIV switch. The LO on the  $\overline{XY}$  line is applied to the Reset input of U317A to select the Channel 2 signal for display. This LO is also applied to U305B pin 4 and to U305D pin 13 via U305A to set up the Trigger Switching Logic that enables the Channel 1 Trigger Pickoff Amplifier.

A LO on U305B pin 4 ensures that the output of U305B pin 6 is a LO, which is applied to the  $\overline{CH\ 1\ Trig}$  signal line to disable the Channel 2 Trigger Pickoff Amplifier. The LO on U305D pin 13 is gated to U315B pin 5. With U315B pin 5 LO, the output of U315B will be a HI that, when ANDed with the HI present from U305C pin 8, enables the Channel 1 Trigger Pickoff Amplifier.

## TRIGGER

The Trigger circuit, shown on Diagram 4, is composed of the Internal and External Trigger Amplifiers, Source-switching circuit, and Trigger Generator circuit. Included in the Trigger Generator circuit is the Auto Trigger and Auto Baseline circuitry and the TV Triggering circuitry.

### Internal Trigger Amplifier

The Internal Trigger Amplifier converts the differential current input from the Trigger Pickoff circuit to a zero-referenced, single-ended output for use by the A and B Trigger Level Comparators. Differential signals from the Pickoff Amplifier circuit are connected via R421 and R422 to common-base transistors U421E and U421D respectively. Transistor U421C and R428 constitute an inverting-feedback amplifier that converts U421D collector current to a voltage at the collector of U421C. This voltage is added in phase with the voltage drop across R427 produced by the signal current of U421E. The resulting sum is a single-ended voltage signal that is applied to the base of emitter-follower U421A. The emitter-follower stage provides a low-output-impedance signal source that drives both the XY Amplifier (through R701) and the emitter-follower (U421B) and supplies the trigger signal to the Alternate B Sweep circuitry. The output signal from U421B is applied to the Trigger Source Switching Diode circuit at the cathode of CR440 where it is available for selection as the triggering signal.

### Trigger Source-Switching Circuit

Trigger signal selection is accomplished by using the A SOURCE switch (S440) to enable one of three triggering signal paths (internal, external, or line) to the Trigger Level Comparator circuit. With S440 set to INT, the inhibiting voltage is removed from R438, causing both U421B and diode CR440 to be biased on. The internal trigger signal is then passed from the emitter of U421B through diode CR440 to the Trigger Level Comparator and Auto Trigger circuits. The A SOURCE switch prevents the line and external triggering signals from reaching the Trigger Level Comparator by reverse biasing diodes CR444 and CR448 and also by reverse biasing Q414 and CR418 through R417.

When S440 is set to LINE, U421B and CR418 are biased off through R438 and R417 respectively, while CR444 is enabled by removal of the inhibiting voltage from R446. Similarly, with S440 set to EXT, the external trigger signal is selected by biasing off CR444 and U421B through resistors R444 and R438 respectively and by enabling Q414 through the removal of the inhibiting voltage from R417.

### A External Trigger Amplifier

The A External Trigger Amplifier provides a means of triggering the instrument from an externally supplied signal that can be applied to the EXT INPUT connector. Input coupling to the Amplifier is selectable by the three-position A EXT COUPLING switch, S401. In the AC position, the dc component of the external trigger signal is blocked by coupling the signal through C402. In the DC position, all components of the signal are coupled directly to the gate of Q411A through an input divider composed of R404 and R408. Resistors R402 and R403 form a voltage-divider network that attenuates the signal by a factor of 10 whenever S401 is set to DC÷10.

Field-effect transistors Q411A and Q411B are a matched pair. Source-follower Q411A provides a high input impedance for the external trigger signal. Current-source transistor Q411B causes Q411A to operate at zero gate-to-source bias, so the device functions with no dc offset between the input and output signals. The output signal from the source of Q411A drives the base of emitter follower Q414. The emitter-follower stage lowers the output impedance of the Trigger Amplifier and functions as part of the Trigger Source Switching circuitry.

### Auto Trigger Circuit

When either AUTO or TV FIELD triggering is selected, the Auto Trigger circuit detects positive and negative peaks of the input trigger signal and produces output voltages that set the A TRIGGER LEVEL control range to within the peak-to-peak amplitude of the triggering signal. The peak detectors are disabled when S611 is set to NORM, and

fixed voltage levels are applied to both ends of A TRIGGER LEVEL potentiometer R455.

In either AUTO or TV FIELD, the A TRIGGER MODE switch (S611) opens the Auto Disable signal line to allow CR503 and CR504 to become reverse biased. This action isolates the voltage divider network (composed of R525, R527, R528, R526, and Q519) from the + inputs of U507A and U507B. The peak detectors (composed of Q503 for the positive peak and Q504 for the negative peak) become enabled when the Auto Disable signal is removed.

The trigger signal is applied to the bases of Q503 and Q504 via R444. Positive trigger signal peaks bias Q503 into conduction, causing its emitter voltage level to rise to the peak level of the trigger amplitude minus the base-to-emitter voltage drop.

Capacitor C503 charges up to the positive emitter voltage level. The charge is retained between trigger pulses due to the long RC time constant of R505 and C503. The comparator voltage is applied to U507A pin 3 which is a voltage follower and level shifter that sets the voltage at one end of the A TRIGGER LEVEL potentiometer (R455). Transistor Q507 provides the feedback path for U507A and thermally compensates for Q503. The base-to-emitter drop of Q507 corrects for the dc offset introduced by Q503, and potentiometer R511 is adjusted to balance out dc offsets introduced from the trigger circuitry.

The negative peak detector operates in the same manner as the positive peak detector, with corresponding components performing the identical circuit function on the trigger-signal negative peaks.

When S611 is set to NORM, +8.6 V is applied through the switch to R525 and R517. Transistor Q519 is biased into saturation by the positive voltage, and both CR503 and CR504 become forward biased. This action reverse biases peak detector transistors Q503 and Q504 to prevent the trigger signal from affecting the A TRIGGER LEVEL control range.

With CR503 and CR504 forward biased, the voltage divider network (R525, R527, R526, and R528) sets the input voltage to U507A pin 3 and U507B pin 5. A fixed positive output voltage from U507A pin 1 is applied to one end of R455, and a fixed negative output voltage from U507B pin 7 is applied to the other end of R455.

### Trigger Level Comparator

The Trigger Level Comparator circuit determines both the trigger level and slope at which a triggering signal is produced. Transistors U460E and U460B form a comparator circuit. It compares the trigger signal level applied to the base of U460E with the reference dc level set by the A TRIGGER LEVEL potentiometer (R455) and applied to the base of U460B. Slope switching is accomplished by controlling the biasing of transistor pairs U460A-U460D and U460C-U460F.

When AUTO or TV FIELD triggering is selected, the Auto Trigger circuit maintains a dc level range at the base of U460B that is dependent upon the amplitude of the trigger input signal. In this instance, the Comparator (U460E and U460B) determines the point on the input trigger waveform at which the Schmitt Trigger circuit will produce an output.

When NORM triggering is selected, the A TRIGGER LEVEL potentiometer (R455) is set manually to a dc level that will produce a trigger signal at the output of the Comparator. If the trigger signal amplitude at the base of U460E is below the reference level, the Schmitt Trigger circuit will never switch. If the trigger signal is above the reference level, the Schmitt Trigger circuit output will switch HI and remain HI until either the trigger signal is decreased or the reference dc level is increased.

The A TRIGGER SLOPE switch (S464) controls the bias on U460C and U460F. When set to the positive slope position, the ground is removed from the bottom end of R464, and the forward bias is then determined by the voltage divider formed by R462 and R463. Both U460C and U460F are biased into conduction and carry the signal current from the Comparator transistors. Moving the SLOPE switch to the negative slope position grounds the bottom of R464 and reduces the bias level of U460C and U460F. The fixed bias level on the bases of U460A and U460D is now higher than the bias on U460C and U460F so that U460A and U460D carry the signal current from the Comparator transistors. The collectors of U460A and U460D are cross connected to the collectors of U460F and U460C, so the resulting trigger signal output is inverted.

### Inverting Amplifier and TV Trigger Circuit

Current from one transistor of the conducting pair of transistors chosen by SLOPE switch S464 is applied to U480C pin 10. Current from the other side of the Comparator is applied to pin 14 at the output side of U480C through R468. Pin 11 of U480C is at a LO logic level except when TV FIELD triggering is enabled. This LO does not affect circuit operation in either AUTO or NORM triggering.

NOR-gate U480C is an emitter-coupled logic (ECL) device that is operated in the linear region. In the linear region, U480C acts as a high-speed inverting amplifier. Common-mode signals such as noise or thermal drift in the Comparator output signal are cancelled by U480C and associated circuitry. These types of offsets equally affect the outputs from both sides of the Comparator. Changing current to pin 10 of U480C causes a corresponding voltage change at U480C pin 14. The voltage change at one end of R468 is equal in amount and opposite in direction to the voltage change at the other end since the same common-mode signal from the other half of the Comparator is applied to the other end of R468.

When the A TRIGGER MODE switch is set to TV FIELD, +8.6 V is applied to the TV Trig Enable signal line. Transistors Q474 and Q476 are biased on via R474, and U480C pin 11 is set HI, causing the output of U480C at pin 14 to be LO.

Current flowing through R466 from either U460C or U460D causes a voltage drop that establishes the bias voltage on the base of Q474. Current flowing through R473 and R472 produces a voltage drop across R473 that establishes the bias voltage on the base of Q476. The circuit components are selected such that when the Comparator output voltages from both halves are equal, the base voltages to both Q474 and Q476 will be the same. With equal base voltages, each transistor will conduct an equal amount of current.

When the Comparator output becomes unbalanced, due to an input trigger signal, unequal biasing of Q474 and Q476 occurs. In response to a changing bias condition, the collector currents vary proportionally.

The collector current changes from Q474 are filtered by a network composed of C476, C477, R477, and R478. The filter network rejects TV video information and averages the TV horizontal-sync pulses. Setting the trigger-level threshold at near the center of the horizontal-sync-pulse swing establishes the untriggered level. When the TV vertical-sync block occurs, the output of the filter rises to a level that will cause the Schmitt Trigger circuit to switch. Precise TV field synchronization is obtained as a result of the filtering action.

The output signal from the filter is applied to U480B pin 6. The Schmitt Trigger circuit responds only to the TV sync signal because pin 7 is held LO by the output of U480C.

## Schmitt Trigger Circuit

With a LO on U480B pin 7, the output at pin 3 goes LO as soon as the signal on U480B pin 6 reaches the switching threshold. The LO is applied to U480A pin 4 and, together with the fixed LO on pin 5, causes the output of U480B pin 6 via R480 to reinforce the switching action. As a result, the output signal at U480A pin 2 switches rapidly.

When the level from the filter network falls to the LO threshold level, the feedback supplied by R480 holds the Schmitt Trigger switched HI for a short time. The amount of time involved prevents noise occurring exactly at the threshold level from causing false triggering.

When either AUTO or NORM triggering is selected, input pin 6 of U480B is held LO, and the Comparator output signal on U480B pin 7 supplies the input to the Schmitt Trigger circuit.

The output of the Schmitt Trigger circuit is obtained from U480D pins 9 and 15. The differential output signal derived from U480D is applied to a two-transistor level-shifting circuit composed of Q492 and Q493. The level-shifting circuit converts the ECL logic levels to TTL logic levels required for the Sweep Generator. A signal obtained from the collector of Q493 is used to drive the Auto Baseline circuit.

## Auto Baseline Circuit

The Auto Baseline circuit (composed of U640A, Q605, and associated components) is enabled in both AUTO and TV FIELD triggering modes. This circuit provides a signal to the Sweep Generator circuit (Diagram 5) that initiates a sweep if a triggering signal is not received by the Schmitt Trigger circuit within a period of about 100 ms. A second output from the circuit illuminates the TRIG'D LED on the instrument front panel when the sweep is triggered.

When adequate triggering signals are being received, the output of Q493 is applied to pin 5 of monostable multivibrator U640A. The negative-going edge of the signal causes pin 6 of U640A to switch HI. The HI forward biases CR615, and Q605 is then biased into conduction. With Q605 conducting, the Auto Baseline signal line is held LO to prevent the Sweep Generator circuit from free running.

The amount of time that pin 6 of U640A stays HI without receiving an input signal is determined by timing components R614 and C614. If a trigger signal is not received in about 100 ms, pin 6 of U640A will go LO and Q605 will be biased off. The Auto Baseline signal line then

goes HI through pull-up resistor R610, and the Sweep Generator free runs to produce the baseline trace.

In NORM triggering mode, the Auto Disable signal (+8.6 V) is applied to the base circuit of Q605 via CR611 and R611. The signal holds Q605 forward biased and prevents the Sweep Generator from free running.

The other function of the Auto Baseline circuit is to illuminate the TRIG'D LED when the sweep is properly triggered. As long as U640A pin 6 remains HI (triggering signals occurring with the proper time), TRIG'D LED DS618 will be illuminated. The trigger mode in use does not affect the operation of the TRIG'D LED.

### A SWEEP GENERATOR AND LOGIC

The Sweep Generator and Logic circuitry, shown on Diagram 5, produces a sawtooth voltage that is amplified by the Horizontal Amplifier to provide horizontal deflection on the crt. This sawtooth voltage (sweep) is produced on command from the Sweep Logic circuits. The Sweep Generator circuits also produce gate waveforms that are used by the Auto Intensity and Z-Axis circuits to establish the correct timing of the crt unblanking and intensity levels used for viewing the display. See Figure 3-5 for the A Sweep timing diagram.

The Sweep Logic circuitry controls the holdoff time, starts the sweep upon reception of a trigger signal, and terminates the sweep at the proper sweep level. When using AUTO or TV FIELD triggering, the Sweep Logic circuitry will cause the Sweep Generator to free run, producing a baseline trace if a trigger signal is not received within the predetermined time period.

### Miller Sweep Generator

The Miller Sweep circuit is composed of Q630A, Q630B, Q631, and associated timing components. The circuit operates to hold the charging current to the timing capacitor at a constant value. When a capacitor is charged in this manner, the rise of voltage across the capacitor is linear rather than exponential.

Field-effect transistors Q630A and Q630B are matched devices. As such, the  $I_{DSS}$  (drain current with gate-to-source shorted) characteristics of each are nearly identical. FET Q630B acts as a source-current supply for Q630A and holds the gate-to-source voltage of Q630B at zero volts.

Before a sweep starts, pin 6 of U620 (the A Sweep Logic Gate) is HI, and both disconnect diodes (CR626 and CR630) are forward biased. The charge on the selected timing capacitor will be zero volts. When U620 pin 6 goes LO, the disconnect diodes become reverse biased and the timing capacitor begins charging through the timing resistor to start the sweep.

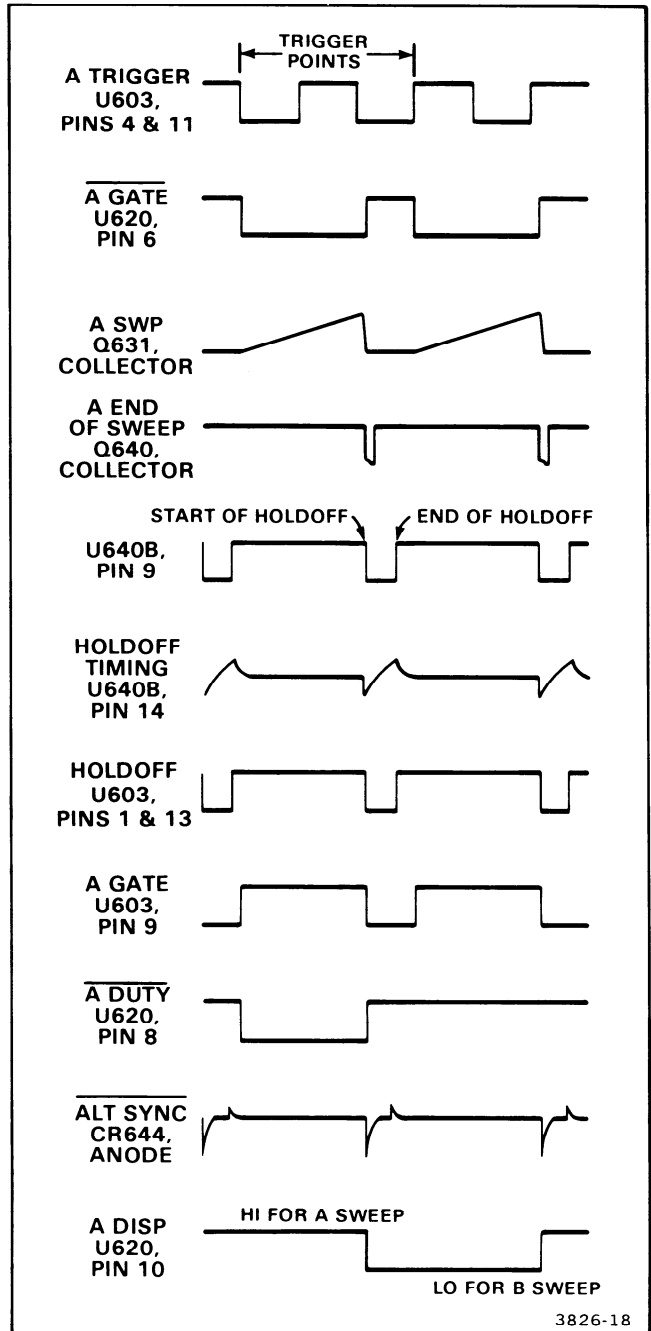

Figure 3-5. A Sweep timing diagram.

The overall gain of the amplifier composed of source-follower Q630A and common-emitter amplifier Q631 is very high. As the timing capacitor charges, Q631 supplies feedback to the gate of Q630A to hold the gate voltage nearly constant. Voltage across the timing resistor is therefore constant, and the charging current to the timing capacitor is constant. The resulting voltage waveform produced at the collector of Q631 is a linear ramp.

When the sweep waveform amplitude reaches about +13 V, the A End-of-Sweep Comparator (Q640) is biased on and the Sweep Logic circuit resets. Pin 6 of U620 goes HI to forward bias disconnect diode CR626, and the current through the timing capacitor reverses direction. The sweep output waveform drops rapidly until disconnect diode CR630 also becomes forward biased. At this point, the Sweep Generator is ready to start another sweep.

### Sweep Logic

Following the sweep completion, a finite time is required to discharge the timing capacitor. The Sweep Logic circuit is prevented from responding to a trigger signal during this time by the Holdoff circuit. The end of sweep (and start of the holdoff period) is determined by the A End-of-Sweep Comparator (Q640).

The A Sweep ramp waveform is applied to the base of Q640 through both a voltage divider and a biasing network composed of R637, R638, and C637. When the ramp amplitude reaches the threshold level of Q640, the collector of Q640 goes LO, and a LO is placed on both U640B pin 11 and U607C pin 10. The output of U607C goes HI, and the positive feedback supplied to the base of Q640 through R639 speeds up the change of state of Q640. By reinforcing the switching action of Q640 in this manner, noise occurring at the threshold level of Q640 is overridden.

The sweep holdoff period commences when the LO from Q640 is applied to pin 11 of monostable multivibrator U640B. The  $\overline{Q}$  output on pin 9 goes LO and remains LO for a length of time determined by the RC timing components connected between pins 14 and 15 of U640B.

Holdoff time can be varied from the normal period by using VAR HOLDOFF control R647. Potentiometer R647 and a voltage divider composed of R645 and R646 establish the charging voltage of holdoff timing capacitors C645, C646, and C647. The capacitor (or combination of capacitors) used is switched into the holdoff circuit by contacts on S630B, the A SEC/DIV timing switch.

During holdoff time, while U640B pin 9 remains LO, the output of U607C will be HI. Inverter U607B will invert the HI to a LO logic level that is then applied to the Reset inputs of both U603A and U603B at pins 1 and 13 respectively. The LO at these inputs holds both flip-flops in the reset state, with the  $\overline{Q}$  outputs HI and Q outputs LO. In the reset state, flip-flops U603A and U603B will not respond to input trigger signals. The Set input of U603B is held HI by the output of U607A and does not affect flip-flop operation. (With AUTO trigger mode selected, a different condition at the Set input of U603B occurs when triggering signals are not received, see Auto Baseline Sweep.)

As long as the Reset input of U603B is held LO, the Q output at U603B pin 9 stays LO. The LO is applied to one of the inputs of all four AND-gates contained in Sweep Logic Gate U620, and output pins 6 and 8 of U620 will be held HI. As previously described, a HI on U620 pin 6 resets the Miller Sweep Generator.

When the timing capacitor is charged up to the reset threshold of U640B, the holdoff time elapses, and U640B switches back to the stable state to place a HI on the  $\overline{Q}$  output (pin 9). The A End-of-Sweep Comparator output on U607C previously became HI when the Miller Sweep Generator finished resetting. With both inputs of U607C now HI, the output on pin 8 is LO. This LO is inverted to a HI by U607B and applied to both U603A and U603B to remove the reset condition. The Q output of U603B at pin 9 will remain LO when the reset is removed, while the Q output on U603A (pin 5) will depend on the state of the Set input when the reset is removed.

If the Set input to U603A is HI when the reset is removed, the Q output will be LO. However, if the Set input is LO, the Q output on U603A will be HI prior to the reset removal, and it will remain HI after the reset is removed. If the Set input of U603A was HI when the reset was removed, the triggering signal will make a negative transition to set U603A before U603B is clocked, since U603B clocks only on positive transitions.

In either case (with the Set input either HI or LO when the holdoff period ends), the Q output of U603A will be HI as U603B is clocked by the first positive transition of the trigger signal after holdoff ends. The HI output present on the D input of U603B (pin 12) is then transferred to the Q output (pin 9), where it is applied to one input of each AND-gate contained in Sweep Logic Gate U620.

The HI is ANDed with the fixed HI supplied by pull-up resistor R608 on U620 pin 4 and inverted by a NOR-gate to produce a LO output on U620 pin 6. As previously described, this LO output reverse biases disconnect diodes CR630 and CR626 to allow the A Sweep to begin.

Gating in the lower half of U620 is concerned with unblanking the display for the A Sweep, as discussed in the following A Z-Axis Switching description.

**A Z-AXIS SWITCHING.** The Z-Drive signal is a combination of input currents that are applied to the Z-axis amplifier (Diagram 6) to establish the display intensity. Switching of the Z-axis drive for the A Sweep is controlled by the A Gate and A Disp input signals to the A Sweep Logic Gate (U620). The A Gate signal is HI during each A Sweep period, but A Disp is HI only during the time the A trace is to be displayed. During the B Sweeps that occur in both ALT and B HORIZONTAL MODE, the A Disp signal is held LO.

When the A Sweep is to be displayed, the signals at U620 pins 9 and 10 are both HI and U620 pin 8 is LO. The LO reverse biases CR620, and the Intens Level current from the Auto Intensity circuit (Diagram 6) passes through CR622 as the A Z-Drive signal. During B Sweep displays, the A Disp signal on U620 pin 10 is held LO and the signal on U620 pin 8 is HI. Diode CR620 becomes forward biased, reverse biasing CR622, and the Intens Level current is prevented from flowing through CR622 to the Z-Drive signal line. With the A Z-Drive signal shut off, the A Sweep display is blanked, and Z-Drive current is supplied by the B Z-Axis Logic circuit (Diagram 10).

**AUTO BASELINE SWEEP.** This feature causes an automatic sweep to be generated after about 100 ms if no trigger signals are received. Generation of the Auto Baseline signal was discussed previously in this section. The Auto Baseline signal is LO either when trigger signals are being received or when the circuit is disabled by using NORM triggering.

The Auto Baseline signal is applied to pin 1 of NAND-gate U607A, while the Holdoff Gate signal is applied to U607A pin 2. As long as the Auto Baseline signal remains LO, the output of U607A on pin 3 will be HI and will not affect the Set input of U603B. When the Auto Baseline signal goes HI in the absence of triggers (using either AUTO or TV FIELD triggering), the output of U607A is an inverted Holdoff Gate signal.

During holdoff, the output of the Holdoff Gate is a LO and places a reset on both U603A and U603B. The reset causes the Q output of U603B to be LO. At the end of the

holdoff period, pin 2 of U607A goes HI, and the reset is removed from U603A and U603B. With both pins 1 and 2 of U607A HI, the output on pin 3 goes LO, and U603B becomes set. Pin 9 of U603B becomes HI and U620 pin 6 goes LO to initiate the A Sweep. As long as no trigger signal is received, U603B will continue to free run in the manner just described to produce a sweep at the end of each holdoff period.

**X-Y DISPLAY.** Switching the A SEC/DIV switch to the X-Y position applies a LO logic level to U640B pin 11 and U607C pin 10 via CR640 and to U607A pin 1 via CR610. The LO applied to U640B pin 11 prevents the Holdoff monostable multivibrator from being triggered. The LO applied to U607C pin 10 and to U607A pin 1 ensures that both U603A and U603B are held in the reset condition and do not respond to input trigger signals.

**ALT SYNC PULSE.** A shaping network connected to U640B pin 9 converts the leading edge of the negative-going holdoff transitions into a narrow pulse suitable for use as a synchronization signal. Zener diode VR644 holds the voltage at one end of C644 at about 3 V, while the  $\bar{Q}$  output of U640B at pin 9 is HI. When the  $\bar{Q}$  output of U640B goes LO at the start of the holdoff period, C644 couples the negative-going edge of the pulse to the Alt Sync signal line.

Capacitor C644 charges rapidly to the new voltage difference through R642 to produce a very narrow pulse output across R642. When the holdoff period ends, the  $\bar{Q}$  output of U640B goes HI again and C644 charges in the opposite direction through VR644. The positive-going edge of the differentiated holdoff pulse is very small in amplitude and does not affect the circuitry to which the Alt Sync signal is applied.

The Alt Sync signal is fed to two places: the Alternate Sweep circuit and the Channel Switching circuit. It is used to synchronize the horizontal display with channel switching transitions when using ALT VERTICAL MODE and to alternately switch between the A and B Sweeps when using ALT HORIZONTAL MODE.

## ALTERNATE B SWEEP

The Alternate B Sweep circuitry, shown on Diagram 10, produces the B sawtooth voltage that is amplified by the Horizontal Amplifier to provide the B Sweep horizontal deflection on the crt. The Alternate B Sweep circuitry also produces the sweep-switching signals, that control the display of the A and B Sweeps, and the gate waveforms used by the Auto Intensity and Z-Axis circuits to establish

the crt unblanking and intensity levels needed for viewing both the A Intensified and B Sweep displays.

The B Sweep sawtooth voltage is produced on command from the B Sweep Logic circuit either immediately after the end of the established delay time (Run After Delay) or upon receipt of the first trigger signal after the delay time has elapsed. The delay time is established by the B Delay Time Position Comparator circuit.

### Run After Delay

The Run After Delay circuit allows the B Sweep Logic to generate a B Sweep independently of any B Trigger signals. In the RUN AFTER DLY mode, the B TRIGGER LEVEL control (R557) is rotated fully clockwise. This biases off Q573 and places a LO logic level on its collector. Inverter U690A will then have a HI output. Resistor R574 provides positive feedback to hold the output HI. The output of U690A is applied to U665C pin 10 and is also inverted through U690B to hold U696A reset.

If the B TRIGGER LEVEL control is not fully clockwise, Q573 is biased on, and the output of U690A is LO. Pin 10 of U665C will then be LO and, with the inverting by U690B, U696A will not be held reset. Operation of the B Sweep Logic circuitry under both of these input conditions is described in the "B Sweep Logic" discussion.

### B Delay Time Position Comparator

The B Delay Time Position Comparator circuit compares the amplitude of the A Sweep sawtooth voltage waveform with the dc voltage level set by the B DELAY TIME POSITION potentiometer (R658). The output of the comparator is used to initiate a B Sweep and to control the B Z-Axis Logic circuit switching.

Transistors U648A and U648B form the Comparator, and U648C acts as a current source for the Comparator. Wiper voltage from the B DELAY TIME POSITION potentiometer is applied to one input of the Comparator at the base of U648A (pin 1). The A Sweep sawtooth voltage is applied to the other Comparator input through a voltage divider composed of R653, R654, and R655. The divider establishes the portion of the sawtooth voltage amplitude that is applied to the base of U648B at pin 5. Delay Dial Gain potentiometer R654 is adjusted in conjunction with Delay Dial Start potentiometer R659 to set the B DELAY TIME POSITION dial accuracy.

Normally U648A in the Comparator is biased on by the dc level set by potentiometer R658, and U648B is biased off. When the sawtooth voltage amplitude at the base of U648B reaches the dc voltage level set by R658 on the base

of U648A, the biasing conditions are reversed, and U648B becomes forward biased while U648A is biased off.

The Comparator output signal from the collector of U648A is applied to the base of U648D at pin 11. Transistors U648D and U648E form a differential amplifier circuit that will either pass the Delay Time signal or block it, depending on the state of the A Only signal. If A Only is HI, Q662 is biased into saturation and CR662 becomes reverse biased. With CR662 reverse biased, the base bias level of U648E enables the Comparator output signal to turn Q664 off and on. In this biasing state, the changes in collector voltage of Q664 are coupled through C664 to U665D pin 13.

When A Only is LO, the B trace will not be displayed. Transistor Q662 is biased off, and the bias level on U648E is established at a level that prevents the Comparator output from turning on U648D. Therefore, U648E remains on with Q664 saturated, and no Delay Time Comparator output signal is obtained.

### B Sweep Logic

The B Sweep Logic circuitry utilizes inputs from the associated B Sweep circuitry to generate a signal controlling both the B Miller Sweep and the B Z-Axis Switching Logic circuits.

In the RUN AFTER DELAY mode (R557 fully clockwise), U696A is held reset by U690B to place a HI on U665B pin 5, and U665C pin 10 is HI. The output of U665B, when LO, will enable the B Miller Sweep, and when HI, will disable the B Miller Sweep. The flip-flop composed of U665A and U665D will determine the output level of U665B through U665C. Input signals to the flip-flop come from the Delay Time Position circuitry (at U665D, pin 13), and from the ANDed output of the Alt Sync signal and the B End-of-Sweep Comparator circuitry (at U665A, pin 1). As long as the input to U665D pin 13 is HI, a B Sweep will not be generated. When U665D pin 13 goes LO, the output at pin 11 will go HI. If Alt Sync (applied to U693A pin 2) is also HI, U665A pin 3 will go LO and initiate a B Sweep through U665C and U665B. The sweep will run until either Alt Sync goes LO or the sweep output biases on the B End-of-Sweep Comparator transistor (Q690). In either case, the output of U693A will go LO, resetting the flip-flop and disabling the B Miller Sweep by setting the B Gate signal at U665B pin 6 HI.

When not in the RUN AFTER DELAY mode, U696A is not held reset (pin 1 is HI), and U665C pin 10 is LO. The output of U665D is LO, holding U696A in the set state to place a LO on U665B pin 5. The B Sweep is initiated on the



first positive pulse from the B Trigger Generator circuitry that occurs after the Delay Gate signal goes LO. Delay Gate going LO will release U696A from the set condition by causing U665D pin 11 to go HI. This HI on pin 11 will also cause U665A pin 3 to go LO, and a LO will be placed on the D input of U696A (pin 2). A positive transition from the B Trigger circuitry will then clock U696A, causing a HI on pin 6 which will make U665B pin 6 LO. The B Miller Sweep will then run until either Alt Sync goes LO or the sweep output biases on the B End-of-Sweep Comparator transistor (Q690) to end the sweep.

### Alternate Display Switching Logic

The Alternate Display Switching Logic circuitry controls both the Horizontal Amplifier sweep switching and the B Z-Axis Logic switching.

HORIZONTAL MODE switch S650 selects the input logic levels that are applied to the circuitry. In A HORIZONTAL MODE, U696B pin 10 is LO and pin 13 is HI. This holds U696B set (Q output HI and  $\bar{Q}$  output LO), allowing only the A Sweep to be passed to the Horizontal Amplifier. In B HORIZONTAL MODE, U696B pin 10 is HI and pin 13 is LO, holding U696B reset and allowing only the B Sweep to go to the Horizontal Amplifier.

With S650 set to ALT and the CH 1-BOTH-CH 2 VERTICAL MODE switch set to CH 1, all of the following pins are HI: U670D pin 13, U690D pin 9, U690E pin 11, and U670A pin 2. The resulting LOs applied to the inputs of U693D from the outputs of U690D and U690E cause the output of U693D (pin 11) to be LO. This LO is inverted by U690F, causing pin 10 of U693C to be HI. Since U696B is not held either set or reset (pins 10 and 13 are both HI), the output state will reverse (toggle) whenever a clock pulse is received on pin 11. Negative-going transitions of the Alt Sync signal will cause the output of U670D to go HI, which transfers through U693C, clocking U696B. With each Alt Sync pulse, the outputs of U696B will toggle to alternately enable the A and B Sweeps to reach the Horizontal Amplifier. For the CH 2 position of the VERTICAL MODE switch, circuit operation is the same except that U690E pin 11 is LO. Whenever the B Sweep is selected for the Horizontal Amplifier, U696B pin 8 will be HI. This HI is applied to U670A pin 1, and since pin 2 is also HI, output pin 3 (Sep) will go LO to enable the A/B Sweep Separation circuitry (Diagram 3).

When the VERTICAL MODE CH 1-BOTH-CH 2 switch is set to BOTH, the ADD-ALT-CHOP switch becomes functional. In the VERTICAL MODE ALT position, the following conditions are present: the Valt signal is LO, the Halt signal is HI, and the CH 1 Sel signal is a TTL square wave that switches states at the end of the A Sweep.

The output of U670D will be HI to enable the output of U693C to change with level changes of the CH 1 Sel signal that is gated through U690E, U693D, and U690F. Since only positive transitions on the clock input of U696B will cause U696B to change states, two A Sweeps are required to cause U696B output levels to switch. With this switching arrangement, the crt will first display the two A Intensified Sweeps and then the two alternate B Sweeps.

In the VERTICAL MODE CHOP position, the CH 1 Sel signal is HI and the Valt signal is LO. Input pin 10 of U693C will always be HI, and pin 9 will receive the Alt Sync signal gated through U670D. The outputs of U696B will therefore toggle whenever its clock input receives a positive transition. The Horizontal Amplifier will alternately receive first A and then B information.

For the VERTICAL MODE ADD position, the CH 1 Sel signal is LO. The outputs of U696B will change states with the Alt Sync signal which is gated through U670D and U693C.

### B Z-Axis Logic

The B Z-Axis Switching Logic circuitry switches the B Z-Drive signal to supply current to the Z-Axis Amplifier for both the B and the A Intensified Sweep displays. The current supplied is summed with the other signal inputs on the Z-Drive line to produce the complete display intensity level. Figure 3-6 is a simplified diagram of the Z-Axis Switching Logic that includes the A Z-Axis Switching Logic circuit.

When HORIZONTAL MODE switch S650 is in the ALT position, pin 5 of U693B is HI. If the outputs of U696B are set for an A display (Q HI and  $\bar{Q}$  LO), then the outputs of U693B and U670B will both be HI. The B Duty signal will therefore be HI, and the B Z-Drive current through R671 (Intens Level from the Auto Intensity circuit, Diagram 6) will be switched off of the Z-Drive line by reverse-biased diode CR671. Z-Drive current will be supplied by the A Z-Axis Logic circuit during this time. When the output of the B Sweep Logic circuit is currently enabling a B Sweep, then the output of U670C will be LO and CR672 will be forward biased. This will enable current from R672 to reach the Z-Drive line where it adds to the A Z-Drive current to produce an intensified A Sweep display. Should a B Sweep not be running, then the output of U670C will be HI, and current from R672 will be prevented from reaching the Z-Drive line by reverse biasing CR672.

If the outputs of U696B are set for a B display (Q LO and  $\bar{Q}$  HI), then the output of U693B will be LO, causing the output of U670C to be HI. This will forward bias CR669 and reverse bias CR672 to prevent the B Z-Drive

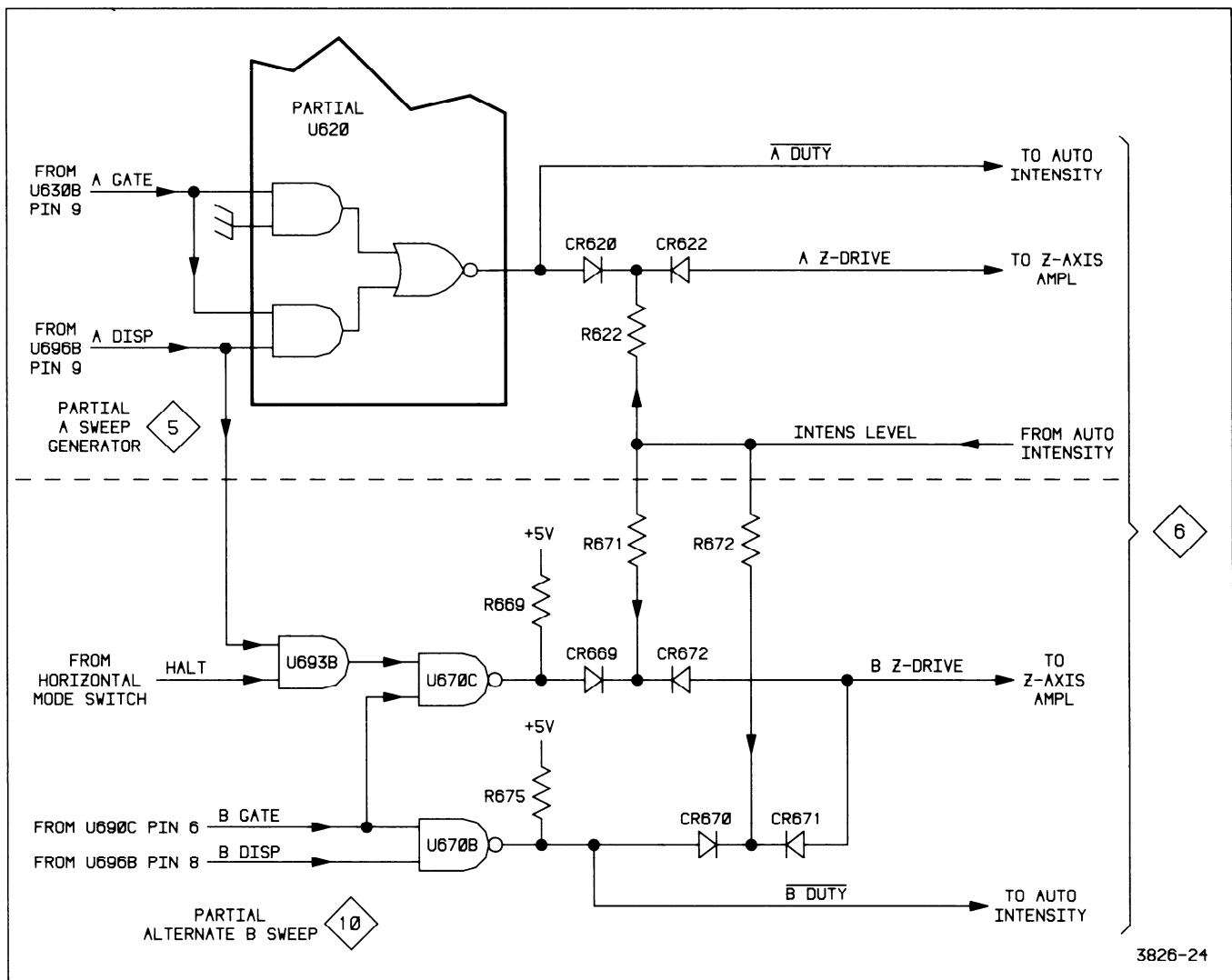

Figure 3-6. Simplified diagram of the Z-Axis Switching Logic circuit.

current (for intensifying the A Sweep) from reaching the Z-Drive line. While a B Sweep is not running, pin 5 of U670B will be LO. Output pin 6 will then be HI, forward biasing CR670 and reverse biasing CR671 to switch off B Z-Drive current from R671 to the Z-Drive line. However, when a B Sweep is enabled, the output of U670B will be LO, thereby forward biasing CR671 to pass current from R671 to the Z-Drive line for a B Sweep display.

## AUTO INTENSITY AND Z-AXIS AMPLIFIER

### Auto Intensity

The purpose of the Auto Intensity circuit, shown in Diagram 6, is to keep the intensity of the trace on the crt at a constant level with changing sweep speeds and trigger

signal repetition rates. In conventional oscilloscopes, as the duty cycle of the displayed trace changes, the intensity will vary. The Auto Intensity circuit compensates for this effect by increasing the Z-Axis Drive voltage for low A Sweep duty factors. The elements of the Auto Intensity circuit consist of four blocks: the duty-cycle averager, the boost-factor converter, the intensity-control multiplier, and the crt triode compensation circuit. The duty-cycle averager consists of an electronic switching circuit composed of U825A, U825B, and U825C. The A Duty signal that is applied to U825B pin 11 causes the output voltage at pin 14 to be switched between ground and +5 V. The output voltage is averaged by R821 and C821. The B Sweep duty-cycle averager operates in an identical manner as the A Sweep duty-cycle averager. The B Duty signal is connected to U825 pin 10 and is averaged by R825 and C825. Bilateral switch U825C, under control of the A Disp signal from the Alternate Display Switching Logic circuit

(Diagram 10), selects which of the two averaged voltages will be connected to the input of U835A.

As the sweep duty factor decreases, the crt beam current must be increased to maintain a constant intensity. To accomplish the task, the boost-factor converter increases the drive in inverse proportion to the duty factor of the trace being displayed.

Amplifier U835A is a high-impedance voltage follower. For 100% duty factor, the output voltage will be approximately zero. Decreasing the duty factor to 10% results in approximately 4.5 V output, and when no sweep occurs (0% duty factor) the output will be 5 V. The output of U835A is applied to a network consisting of CR828, CR830, and resistors R827, R828, R829, R830, and R831. This network produces an output current which is a nonlinear function of the duty-factor voltage. For 10% duty factor, the output current is 10 times greater than the current at 100% duty factor. Maximum available boost limits at a factor of about 25:1.

The nonlinear current is connected to the emitters of the differential amplifier composed of Q811 and Q812. The emitters of the two amplifier transistors are held at a constant voltage by the action of Q813. AUTO INTENSITY control R807 is connected to the base of Q811 via R811. It controls the portion of the boost current that goes to the summing junction of U835B. Boost current is proportional to the true beam current required at the faceplate of the crt.

The crt triode compensation circuit is an inverting operational amplifier with nonlinear feedback. It is composed of U835B, R834, R835, C834, and CR834. Output voltage of the circuit changes in response to the input current in a manner that complements the nonlinear triode characteristics of the crt. This output voltage is applied both to the Intens Level signal line and to the Z-Axis Amplifier via the A and B Z-Axis Logic Switching circuits. The Intens Level signal is also applied to the Focus circuit (Diagram 9) for use in focus tracking of the intensity level changes.

The intensity of the display is allowed to reduce to zero through the action of CR809, VR809, and R809. Without this circuit, the Auto Intensity circuit would not allow the intensity to go to zero when the AUTO INTENSITY control is set to minimum intensity.

### Z-Axis Amplifier

The Z-Axis Amplifier controls the crt intensity level via several input-signal sources. The effect of these input

signals is either to increase or decrease trace intensity or to completely blank portions of the display. The A and B Z-Drive signal current and the input current from the Z-AXIS INPUT connector (if in use) are summed at the emitter of common-base amplifier transistor Q841. The algebraic sum of these signals determines the collector current of Q841. Input transistor Q841 provides a low-impedance termination for the input signals and isolates the signal sources from following stages of the Z-Axis Amplifier.

Signal current from Q841 flows through CR844 and develops a signal voltage drop across R844. Increasing current through Q841 reduces the forward bias of Q844, thereby reducing the current through Q844. This action causes the collector voltage of Q844 to go more negative (toward the  $-8.6$  V supply) and increases the forward bias on emitter-follower Q845. As emitter current of Q845 increases, negative-going voltage developed across R847 is applied to the bases of complementary-pair output transistors Q847 and Q850. Positive transitions of the Z-Axis signal are coupled to the base of Q850 via C852. The fast-rise transitions are amplified by Q850 to speed up the response time. For negative transitions of the Z-Axis signal, as well as for dc and low-frequency signal components, Q847 acts as the amplifier, with Q850 supplying the current.

Diode CR856 prevents the Z-Axis output signal from going negative, and neon lamps DS854 and DS856 provide protection to the Z-Axis Amplifier in the event of high-voltage arcing in the crt.

The amplifier gain with respect to the A or B Z-Drive current is set to about 10 by the negative feedback supplied from the collectors of Q847 and Q850 to the base of Q845 via feedback resistor R846. The gain with respect to the external Z-Axis Input signal is held to about three by R801, R802, and R803 in series with the external input signal. Diodes CR801 and CR802 provide protection for the Z-Axis Amplifier in case of an accidental application of excessive signal amplitude to the Z-AXIS INPUT connector.

When CHOP VERTICAL MODE is selected, the Chop Blank signal is applied to the collector of Q841 during the display switching time. Signal current is shunted away from CR844, and the forward bias of Q844 increases to the blanking level. When blanked, the output of the Z-Axis Amplifier drops to about +10 V, and the crt beam current is reduced to below viewing intensity to eliminate chop switching transients from the display.

For an X-Y display, the A Z-Drive and B Z-Drive signal currents are switched off. When the XY signal is LO, CR837 is forward biased and Intens Level current flows

through R837 to Z-Axis Amplifier transistor Q841 to establish the display intensity.

The last input to the Z-Axis Amplifier is the Beam Find current. Normally, BEAM FIND switch S390 is closed, and  $-8.6$  V is supplied to the base bias network of Q841 and Q844. When the BEAM FIND switch is opened, the  $-8.6$  V is removed, and the bias voltage becomes more positive. Transistor Q841 becomes more forward biased while Q844 becomes much less forward biased. The current through Q844 is reduced, and the base bias voltage of Q845 is thereby increased. The output of Q845 then goes to a level that produces a fixed, predetermined Z-Axis output signal level. Thus neither the AUTO INTENSITY control nor the Z-Drive signal have any control over the intensity level of the crt display whenever the BEAM FIND push button is pressed in, and a bright trace (or dot if no sweep is present) will be displayed.

## HORIZONTAL

The Horizontal Amplifier circuit, shown on Diagram 7, provides the output signals that drive the horizontal crt deflection plates. Signals applied to the Horizontal Pre-amplifier can come from either the A or the B Miller Sweep Generator (for sweep deflection) or from the XY Amplifier (when X-Y display mode is selected). Sweep switching is under control of the Alternate Display Switching Logic circuit (Diagram 10). See Figure 3-7 for a detailed block diagram of the Horizontal Amplifier circuit.

The Horizontal POSITION control, X10 magnifier circuitry, and the horizontal portion of the beam finder circuitry are also contained in the Horizontal Amplifier circuit.

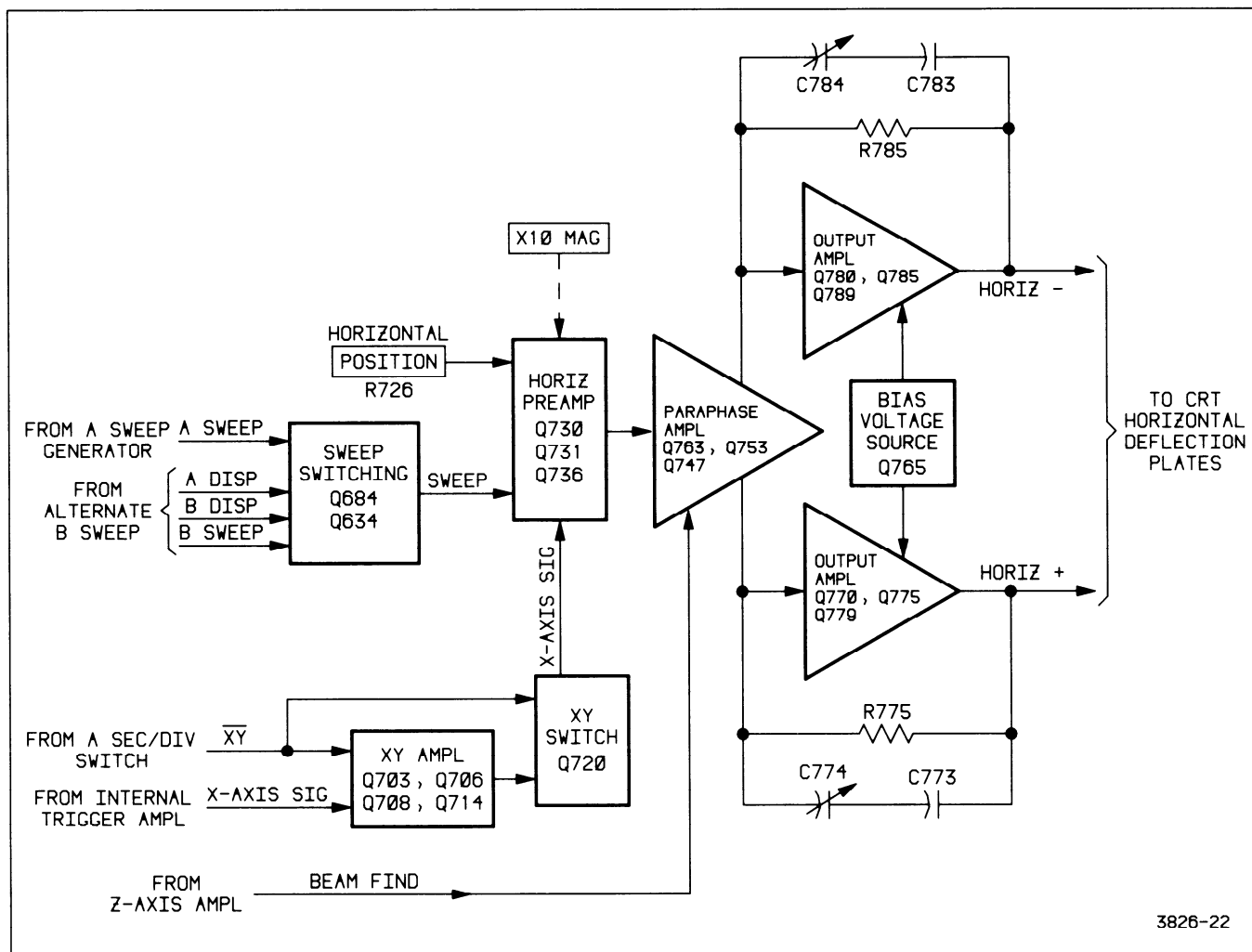

Figure 3-7. Detailed block diagram of the Horizontal Amplifier.

## Sweep Switching

The Sweep Switching circuit is composed of two transistors, Q634 and Q684, acting as switches under control of the Alternate Sweep Switching Logic circuit. Either the A Disp or the B Disp signal is applied to the base of the associated transistor (A Disp to Q684 and B Disp to Q634), and the sweep signals are applied to the collectors of the switching transistors. The A Disp and B Disp signals are complementary (when one is HI the other is LO) so only one sweep signal at a time will be applied to the Horizontal Preamplifier.

**A SWEEP DISPLAY.** To pass the A Sweep to the Horizontal Preamplifier, the A Disp signal is HI. Transistor switch Q684 is biased on, and the B Sweep signal is shunted to ground through the transistor. Since Q634 is biased off, the A Sweep signal is allowed to pass to the preamplifier summing junction at the base of Q730. Sweep signal current is summed with the horizontal positioning current supplied by Horizontal POSITION control R726.

**B SWEEP DISPLAY.** The A Disp signal becomes LO and the B Disp signal applied to the base of Q634 becomes HI. Switching transistor Q634 is biased on, and the A Sweep current is shunted to ground. The B Sweep current passes to the input summing junction to be added to the horizontal positioning current. The B Gain potentiometer (R682) is adjusted to provide the same gain for the B Sweep signal as for the A Sweep signal.

**ALT HORIZONTAL DISPLAY.** The A Disp and B Disp signals are switched at the alternate sweep rate by the Alternate Sweep Switching Logic circuit. When both vertical channels are being viewed simultaneously, the intensified traces of both Channel 1 and Channel 2 are first displayed, then both alternate B traces are displayed.

## Horizontal Preamplifier

The sum of the sweep and positioning current is applied to the input of one side of a differential amplifier composed of Q730 and Q731. For all conditions other than the X-Y Mode, XY Switch transistor Q720 is biased on to provide a ground reference at the other input of the differential amplifier (at the base of Q731). The output of the differential amplifier, taken from the collector of Q731, is amplified by Q736.

A feedback network connected between the output of Q736 and the base of Q730 provides the circuitry required for the X10 magnification feature. In the unmagnified mode, X10 Magnifier switch S734 is closed and the feedback is provided by the paralleled combination of R732 and C732. Resistor R732 sets the unmagnified amplifier gain and C732 provides the HF compensation.

When the X10 Magnifier push button is pressed in, S734 opens and additional components are added to the feedback network. With the feedback reduced, the amplifier gain is increased by a factor of 10. The X10 Gain potentiometer (R733) is adjusted to produce the exact gain required. High-speed linearity compensation of the feedback network is provided by adjustable capacitor C734.

## XY Amplifier

When the X-Y display mode is selected using the A SEC/DIV switch, the  $\overline{XY}$  signal line goes LO and XY Switch transistor Q720 is biased off. The  $\overline{XY}$  signal is also applied to FET Q714 (used as a switch to prevent crosstalk) in the XY Amplifier to bias it on. With this action, the XY Amplifier is enabled to pass X-Axis signals on to the Horizontal Preamplifier. Another function of the  $\overline{XY}$  signal is to disable the A Sweep Generator to prevent the A and B Sweep signals from being applied to the Horizontal Preamplifier.

The X-Axis signal is derived from the Channel 1 internal trigger signal and applied to the base of Q703. Transistor Q703 is one-half of a differential amplifier composed of Q703 and Q706. The base of Q706 is referenced to ground through R706. Transistor Q708 amplifies the output signal from the collector of Q706 and applies it to the drain of FET Q714. A feedback network composed of R709, R708, and C708 is connected between the collector of Q708 and the base of Q703. The feedback network sets the overall gain of the XY Amplifier, with X-Gain potentiometer R709 adjustable to obtain the exact gain required.

The X-Axis signal passes through FET Q714 and is applied to the base of Q731 in the Horizontal Preamplifier. Horizontal positioning current on the base of Q730 is added to the X-Axis signal by the action of the differential amplifier. Then the sum of these two currents is amplified by Q736 and applied to the input of the Horizontal Output Amplifier.

## Horizontal Output Amplifier

The Horizontal Output Amplifier converts the single-ended output of the Preamplifier into the differential output required to drive the crt horizontal deflection plates. The output stage consists of an input paraphase amplifier and an output complementary amplifier.

Horizontal signal voltage from Q736 is applied to the base of Q763. The base of the other transistor (Q753) in the paraphase amplifier, is biased through a voltage divider composed of R758, R757, and R756. Horizontal centering between the X1 and X10 Magnified sweeps is accomplished by adjusting Mag Registration potentiometer R758.

Gain of the paraphase amplifier is determined by components connected between the emitter leads of Q763 and Q753. The exact gain is adjusted by Horiz Gain potentiometer R752.

Transistor Q747 supplies the emitter current to both Q763 and Q753. The horizontal portion of the Beam Find circuitry affects the available current to Q747. Normally,  $-8.6$  V is applied to the emitter of Q747 from the BEAM FIND switch via CR745 and R746. When the BEAM FIND push button is pressed in, the direct  $-8.6$  V is removed. In this condition,  $-8.6$  V is supplied via R745 which reduces the current available, thereby reducing the output voltage swing capability of Q763 and Q753. Diodes CR772, CR782, CR783, and CR773 prevent the paraphase amplifier from overdriving the output amplifier stage when the X10 Magnification feature is in use.

Final amplification of the horizontal deflection signal is provided by the complementary-pair output stage. Both sides of the differential output amplifier are identical in function, so only one side is discussed in detail.

Transistors Q780 and Q785 form a cascode feedback amplifier. Gain of the stage is set by feedback resistor R785, and high-speed compensation is provided by C783 and adjustable capacitor C784. For dc and low-frequency components of the horizontal deflection signal, Q789 acts as a current source for Q785. High-frequency components of the signal are coupled through C789 to the emitter of Q789 to speed up the output response time.

Emitter voltage for both Q780 and Q770 is supplied by a circuit composed of Q765 and associated components. The emitter voltage is maintained at a level that provides proper biasing for Q763 and Q753. Diodes CR770 and CR780 set up an emitter-bias difference between Q780 and Q770, causing the base voltage of both transistors to be equal.

## POWER SUPPLY

The Power Supply circuits provide all the low and high voltages required for operation of the instrument. The circuitry shown in Diagram 9 converts the ac-source voltage to the required levels through the action of a switching power supply. It does not have a primary power transformer.

### Power Input

The Power switch (S901) connects the line voltage to the instrument through line fuse F901 and transient suppressor VR901. Suppressor VR901 protects the instrument

from large voltage transients. High-frequency line noise is attenuated by C901.

### Preregulator

The Preregulator circuit converts the ac-power-source input voltage to a regulated dc voltage. A triac is used as a switch to conduct current during a controlled period of the input-line-voltage cycle so that energy to be used by the Inverter circuit is stored in capacitor C937.

Current from one side of the ac-power-source input will go through L925 (a current-limiting impedance) and triac Q925. Diodes CR931 and CR933 (on the Main board) and CR932 and CR934 (on the Current Limit board) form a full-wave bridge rectifier circuit. The rectifier converts the ac-input voltage into dc pulses that charge C937. Surge arrester VR938, connected in parallel with C937, conducts to protect the following circuitry should the Preregulator output voltage become too high.

The two-transistor circuit composed of Q933, Q938, and associated components provides overcurrent protection in the event of triac misfiring or ac-power-source transients. Transistor Q938 is an insulated-gate FET used as a switch in the charging path of C937. Transistor Q933 controls the FET bias to limit the current under abnormal firing conditions of Q925. In normal power-supply operation, the voltage developed across R937 is not sufficient to bias Q933 into conduction. The gate-to-source voltage of Q938 is set to 10 V by VR934 and R938, so the FET presents a low resistance to the charging current to C937. If triac Q925 should misfire to cause excessive current, Q933 becomes forward biased and Q938 is switched off to reduce the current. When Q938 switches off, the current that was flowing through Q938 flows through R939. The voltage drop developed across R939 causes current to flow through VR933 and R933, which holds Q933 on for most of the remainder of the ac-power-source input cycle. Resistor R939 limits the rate of collapse of the field around L925 to prevent damage to Q938. Thermistor RT935 adjusts the bias of Q933 over varying ambient temperature.

**PREREGULATOR CONTROL.** The ac-source voltage is full-wave rectified by CR903 through CR906 and applied to a voltage divider composed of R911, R912, and R915. Output from this divider serves as a reference voltage for a ramp-and-pedestal comparator utilizing a programmable unijunction transistor (PUT), Q921. Capacitor C912 filters the line noise to prevent false triggering of the PUT. Voltage-dropping resistor R914 provides current for zener diodes VR914 and VR915 to produce constant voltages during each half of the ac-power-source cycle.

When the instrument is first turned on, C917 is not charged. Capacitor C915 charges through CR917 to the

voltage of VR915 minus the diode drop of CR917. When the anode voltage of Q921 is greater than the gate voltage, Q921 will fire and C915 will discharge through the primary of T925. This event will happen after the peak of the voltage waveform. Pulse transformer T925 is connected to the gate of Q925, and the discharge of C915 through the T925 primary winding is coupled to the secondary to cause triac Q925 to conduct. After firing, the triac will turn off again when the sinusoidal source voltage crosses through zero. As C917 charges through R917, Q918 current increases proportionally to charge C915 more rapidly. When C915 charges at a faster rate, the anode voltage of Q921 rises above the gate voltage earlier in the ac-source cycle and thereby causes Q925 to conduct for a longer period of time. The portion of the cycle preceding the zero-crossing point over which the triac is conducting is called the conduction angle. The conduction angle will increase from nearly zero (at turn on) to an angle sufficient to supply the energy needed by the inverter. Feedback from the inverter through optical isolator U931 holds the correct conduction angle by shunting current from R917. This shunting action controls the voltage on C917, thereby controlling the increase in base voltage on Q918. This action controls the charging rate of C915 and therefore the conduction angle of Q925.

The Preregulator circuit can handle a wide range of input voltages by changing the conduction angle of the triac as the input voltage changes. As the input voltage increases, the conduction angle will decrease to maintain the Preregulator output voltage at a constant level. The voltage divider composed of R911, R912, and R915 produces an output voltage proportional to the input line voltage that is applied to the gate of Q921. Since VR914 and VR915 hold bias levels on Q918 constant regardless of input voltage, the point on the cycle at which Q921 fires will vary with changes in the ac-source voltage. This feed-forward, together with the feedback from the Inverter through optical isolator U931, ensures a constant Preregulator output to the Inverter.

### Inverter

The Inverter circuit changes the dc voltage from the Preregulator to ac for use by the supplies that are connected to the secondaries of T940.

The output of the Preregulator circuit is applied to the center tap of T940. Power-switching transistors Q940 and Q942 alternate conducting current through R941 from the primary circuit common to the Preregulator output line. The transistor switching action is controlled by T942, a saturating base-drive transformer.

When the instrument is first turned on, one of the switching transistors will start to conduct and the collector

voltage will drop toward the common voltage level. This will induce a positive voltage from the lead of T942 which is connected to the base of the conducting transistor to reinforce conduction. Eventually T942 will saturate, and as the voltage across T942 (and T940) begins to reverse, the conducting transistor cuts off because of the drop in base drive. The other transistor will not start conduction until the voltage on the leads of T942 reverse enough to bias it on. This process will continue, and the saturation time of T942 plus the transistor-switching time will determine the frequency of Inverter operation (typically 20 kHz). After the initial Inverter start up, the switching transistors do not saturate; they remain in the active region during switching.

Diodes CR940 and CR942 serve as a negative-peak detector to generate a voltage for controlling the outputs of both the Preregulator and the error amplifier. Capacitor C951 will charge to the peak amplitude of the collector voltage of Q940 and Q942. This voltage level is applied to the divider composed of R945, R946, and R947. The error amplifier, composed of Q948 and Q954, is a differential amplifier that compares the reference voltage of VR951 with the voltage on the wiper of potentiometer R946. The current through Q954 will set the base drive of Q956 and thereby control the voltage on C957. This voltage will bias Q940 and Q942 to a level that will maintain the peak-to-peak input voltage of T940. The amplitude of the voltage across the transformer primary winding and thus, that of the secondary voltages of T940, is set by adjusting –8.6 V Adj potentiometer R946.

At turn on, Q948 is biased off and Q954 is biased on. All the current of the error amplifier will therefore go through Q954 to bias on Q956. Diode CR956 allows the base of Q956 to go positive enough to initially turn on Q940 or Q942. The current through Q956 controls the base drive for Q940 and Q942. Base current provided by base-drive transformer T942 will charge C957 negative with respect to the Inverter circuit floating ground (common) level.

Voltage from CR940 and CR942 also provides a measurement of the minimum collector voltage of Q940 and Q942 with respect to the Inverter circuit floating ground. This voltage is fed back to the Preregulator through optical isolator U931 to control the output voltage from the Preregulator circuit. As the negative peak voltage at the collectors of the switching transistors is regulated by the error amplifier with respect to the output of the Preregulator, control of the dc level from the Preregulator will control the minimum voltage with respect to the floating ground. Potentiometer R952 (Head Room Voltage Adjust) is used to set this minimum voltage level to a point that prevents saturation and excessive power dissipation of the Inverter switching transistors.

## CRT Supply

High-voltage multiplier U990 utilizes the 2-kV winding of T940 to generate 8 kV at one output to drive the crt anode. It also uses an internal half-wave rectifier diode to produce  $-2$  kV for the crt cathode. The  $-2$  kV supply is filtered by a three-stage low-pass filter composed of C990, R992, R990, C992, R994, C995, and R995. Neon lamp DS870 protects against excessive voltage between the crt heater and crt cathode by conducting if the voltage exceeds approximately 75 V.

## Auto Focus Circuit

Focus voltage is also developed from the  $-2$  kV supply via a voltage divider composed of R884, R882, AUTO FOCUS potentiometer R883, R881, R880, R879, R878, R872, Auto Focus Adjust potentiometer R875, and Q877. The focus voltage tracks the intensity level through the action of Q877. The Intens Level signal from the Auto Intensity circuit (Diagram 6) is applied to the emitter of Q877 through R877. When the Intens Level signal changes due to a changing display intensity, the current through the divider resistors changes proportionally. Auto Focus Adjust potentiometer R875 is adjusted to produce the best focus tracking.

## Low-Voltage Supplies

The low-voltage supplies utilize the secondary windings of T940 and are all full-wave, center-tapped bridges. The  $+100$  V supply uses CR961 and CR963 for rectification and uses C961 for filtering. Diodes CR965 and CR967 rectify ac from taps on the 100-V winding, and C965 filters the output to produce  $+30$  V dc. The diode bridge consisting of CR971 through CR974 produces the  $+8.6$  V and  $-8.6$  V supplies. Filtering of the  $+8.6$  V is accomplished by C971, C975, and L971; while filtering of the  $-8.6$  V is done by C972, C976, and L972. Voltage regulator U985 uses the rectified  $+8.6$ -V supply to produce the  $+5$ -V output. Diode CR985 protects the regulator by not allowing the output voltage to go more positive than the  $+8.6$  V input voltage.

## DC Restorer

The DC Restorer circuit produces the crt control-grid bias and couples both dc and low-frequency components of the Z-Axis Amplifier output to the crt control grid. Direct coupling of the Z-Axis Amplifier output to the crt control grid is not employed due to the high potential differences involved. Refer to Figure 3-8 during the following discussion.

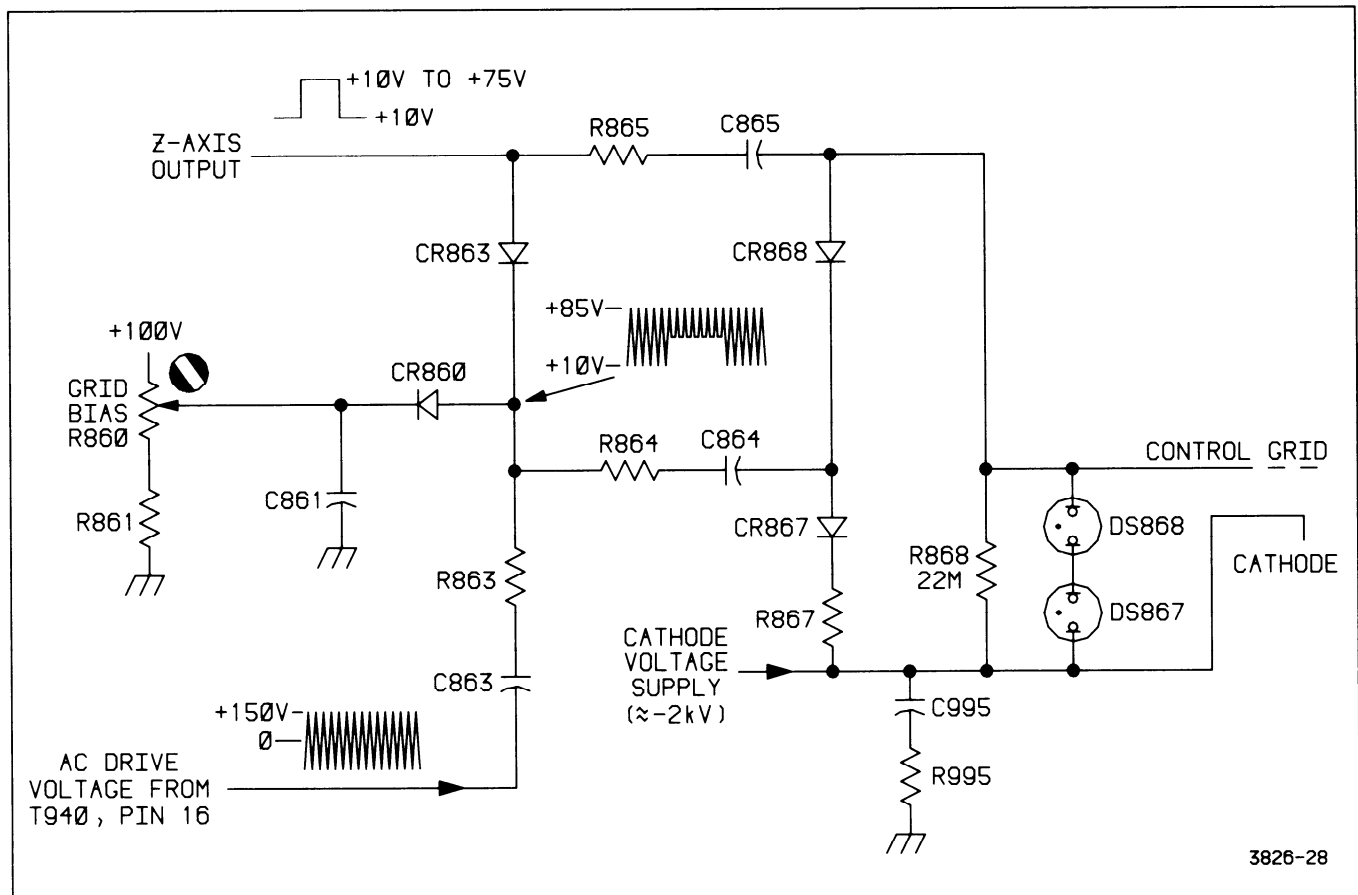

Figure 3-8. Simplified diagram of the DC Restorer circuit.



## Theory of Operation—2215 Service

The ac drive to the DC Restorer circuit is obtained from pin 16 of T940. The drive voltage has a peak amplitude of about 150 V and a frequency of about 20 kHz. The sinusoidal drive voltage is coupled through C863 and R863 into the DC Restorer circuit at the junction of CR860, CR863, and R864. The cathode end of CR860 is held at about +85 V by the voltage applied from the wiper of Grid Bias potentiometer R860. When the positive peaks of the ac-drive voltage reach a level that forward biases CR860, the voltage is clamped at that level.

The Z-Axis Amplifier output-signal voltage is applied to the DC Restorer at the anode end of CR863. The Z-Axis signal voltage level varies between +10 V and +75 V, depending on the setting of the AUTO INTENSITY control. The ac-drive voltage will hold CR863 reverse biased until the voltage falls below the Z-Axis Amplifier output voltage level. At that point, CR863 becomes forward biased and clamps the junction of CR860, CR863, and R864 to the Z-Axis output level. Thus, the ac-drive voltage is clamped at two levels on the positive swing of the cycle to produce an approximate square-wave signal with a positive dc-offset level.

The DC Restorer is referenced to the –2-kV crt cathode voltage through R867 and CR867. Initially, both C865 and C864 will charge up to a level determined by the difference between the Z-Axis output voltage and the cathode voltage. Capacitor C865 charges from the crt cathode through R867, CR867, CR868, and R865 to the Z-Axis output. Capacitor C864 charges through R867, CR867, R864, and CR863 to the Z-Axis output.

When the ac-drive voltage starts its positive transition from the lower clamped level toward the higher clamped level, the charge on C864 increases due to the rising voltage.

The increase in charge acquired by C864 is proportional to the amplitude of the positive transition. When the ac-drive voltage starts its negative transition from the upper clamped level to the lower clamped level, the negative transition is coupled through C864 to reverse bias CR867 and to forward bias CR868. The increased charge of C864 is then transferred to C865 as C864 discharges toward the Z-Axis output level. The amount of charge that is transferred is proportional to the setting of the AUTO INTENSITY control, since that control sets the lower clamping level of the ac-drive voltage.

The added charge on C865 also determines the control-grid bias voltage. If more charge is added to the charge already present on C865, the control grid becomes more negative, and less crt writing-beam current will flow. Conversely, if less charge is added, the control-grid voltage level will be closer to the cathode-voltage level, and more crt writing-beam current flows.

During periods that C864 is charging, the crt control-grid voltage is held constant by the long time-constant discharge path of C865 through R868.

Fast-rise and fast-fall transitions of the Z-Axis output signal are coupled to the crt control grid through C865. The fast transitions start the crt writing-beam current toward the new intensity level. The DC Restorer output level then follows the Z-Axis output-voltage level to set the new bias voltage for the crt control grid.

Neon lamps DS867 and DS868 protect the crt from excessive grid-to-cathode voltage if the potential on either the control grid or the cathode is lost for any reason.

# PERFORMANCE CHECK PROCEDURE

## INTRODUCTION

### PURPOSE

The “Performance Check Procedure” is used to verify the instrument’s Performance Requirements as listed in the “Specification” (Section 1) and to determine the need for readjustment. These checks may also be used as an acceptance test, as a preliminary troubleshooting aid, and as a check of the instrument after repair. Removing the instrument’s cover is not necessary to perform this procedure. All checks are made using the operator-accessible front- and rear-panel controls and connectors.

To ensure instrument accuracy, its performance should be checked after every 2000 hours of operation or once each year, if used infrequently.

Special fixtures are used only where they simplify the test setup and procedure. These fixtures are available from Tektronix, Inc. and can be ordered by part number through your local Tektronix Field Office or representative.

### LIMITS AND TOLERANCES

The tolerances given in this procedure are valid for an instrument that is operating in and has been previously calibrated in an ambient temperature between +20°C and +30°C. The instrument also must have had as least a 20-minute warm-up period. Refer to the “Specification” (Section 1) for tolerances applicable to an instrument operating outside this temperature range. All tolerances specified are for the instrument only and do not include test-equipment error.

### TEST EQUIPMENT REQUIRED

The test equipment listed in Table 4-1 is a complete list of the equipment required to accomplish both the “Performance Check Procedure” in this section and the “Adjustment Procedure” in Section 5. Test equipment specifications described in Table 4-1 are the minimum necessary to provide accurate results. Therefore, equipment used must meet or exceed the listed specifications. Detailed operating instructions for test equipment are not given in this procedure. If more operating information is required, refer to the appropriate test-equipment instruction manual.

When equipment other than that recommended is used, control settings of the test setup may need to be altered. If the exact item of equipment given as an example in Table 4-1 is not available, first check the “Purpose” column to verify use of this item. If it is used for a check that is of little or no importance to your measurement requirements, the item and corresponding steps may be deleted. If the check is important, use the “Minimum Specification” column carefully to determine if any other available test equipment might suffice.

### PREPARATION

Test equipment items 1 through 9 in Table 4-1 are required to accomplish a complete Performance Check. At the beginning of each subsection, in both the “Performance Check Procedure” and the “Adjustment Procedure” sections, there is an equipment-required list showing only the test equipment necessary for performing the steps in that subsection. In this list, the item number that follows each piece of equipment corresponds to the item number listed in Table 4-1.

This procedure is structured in subsections, which can be performed independently, to permit checking individual portions of the instrument. At the beginning of each subsection is a list of all the front-panel control settings required to prepare the instrument for performing Step 1 in that subsection. Each succeeding step within a particular subsection should then be performed, both in the sequence presented and in its entirety, to ensure that control-setting changes will be correct for ensuing steps.

**Table 4-1**  
**Test Equipment Required**

Item No. and Description	Minimum Specification	Purpose	Examples of Suitable Test Equipment
1. Calibration Generator	Standard-amplitude signal levels: 10 mV to 50 V. Accuracy: $\pm 0.3\%$ .  High Amplitude signal levels: 1 V to 60 V. Repetition rate: 1 kHz.  Fast-rise signal level: 1 V. Repetition rate: 1 MHz. Rise time: 1 ns or less. Flatness: $\pm 0.5\%$ .	Vertical and horizontal checks and adjustments.	TEKTRONIX PG 506 Calibration Generator. <sup>a</sup>
2. Leveled Sine-Wave Generator	Frequency: 250 kHz to above 70 MHz. Output amplitude: variable from 10 mV to 5 V p-p. Output impedance: 50 $\Omega$ . Reference frequency: 50 kHz. Amplitude accuracy: constant within 3% of reference frequency as output frequency changes.	Vertical, horizontal, and triggering checks and adjustments. Display adjustment and Z-axis check.	TEKTRONIX SG 503 Leveled Sine-Wave Generator. <sup>a</sup>
3. Time-Mark Generator	Marker outputs: 10 ns to 0.5 s. Marker accuracy: $\pm 0.1\%$ . Trigger output: 1 ms to 0.1 $\mu$ s, time-coincident with markers.	Horizontal checks and adjustments. Display adjustment.	TEKTRONIX TG 501 Time-Mark Generator. <sup>a</sup>
4. Cable (2 required)	Impedance: 50 $\Omega$ . Length: 42 in. Connectors: bnc.	Signal interconnection.	Tektronix Part Number 012-0057-01.
5. Termination (2 required)	Impedance: 50 $\Omega$ . Connectors: bnc.	Signal termination.	Tektronix Part Number 011-0049-01.
6. Dual-Input Coupler	Connectors: bnc-female-to-dual-bnc male.	Vertical checks and adjustments.	Tektronix Part Number 067-0525-01.
7. 10X Attenuator	Ratio: 10X. Impedance: 50 $\Omega$ . Connectors: bnc.	Vertical compensation and triggering checks.	Tektronix Part Number 011-0059-02.
8. T-Connector	Connectors: bnc.	Signal interconnection.	Tektronix Part Number 103-0030-00.
9. Adapter	Connectors: bnc-male-to-miniature probe tip.	Signal interconnection.	Tektronix Part Number 013-0084-02.
10. Variable Auto-transformer	Capable of supplying 1.5 A at 115 V.	Instrument input voltage adjustment.	General Radio W8MT3VM Variac Autotransformer.

Table 4-1 (cont)

Item No. and Description	Minimum Specification	Purpose	Examples of Suitable Test Equipment
11. Digital Voltmeter	Range: 0 to 140 V. Dc voltage accuracy: $\pm 0.15\%$ . 4 1/2-digit display.	Power supply checks and adjustment. Vertical adjustment.	TEKTRONIX DM 501A Digital Multimeter. <sup>a</sup>
12. Test Oscilloscope with included 10X probe (Standard Accessory) and 1X probe (1X probe is optional accessory).	Bandwidth: dc to 10 MHz. Minimum deflection factor: 5 mV/div. Accuracy: $\pm 3\%$ .	Power supply ripple check and general troubleshooting.	a. TEKTRONIX 2213 Oscilloscope. b. TEKTRONIX P6101 Probe (1X). Part Number 010-6101-03.
13. DC Voltmeter	Range: 0 to 2500 V, calibrated to 1% accuracy at -2000 V.	High-voltage power supply check.	Triplett Model 630-NA.
14. Screwdriver	Length: 3-in shaft. Bit size: 3/32 in.	Adjust variable resistors.	Xcelite R-3323.
15. Low-Capacitance Alignment Tool	Length: 1-in shaft. Bit size: 3/32 in.	Adjust variable capacitors.	J.F.D. Electronics Corp. Adjustment Tool Number 5284.

<sup>a</sup>Requires a TM 500-series power-module mainframe.

## INDEX TO PERFORMANCE CHECK STEPS

Vertical	Page
1. Check Deflection Accuracy and Variable Range . . .	4-4
2. Check Bandwidth . . . . .	4-5
3. Check Common-Mode Rejection Ratio . . . . .	4-5

Horizontal	Page
1. Check Timing Accuracy . . . . .	4-6
2. Check Delay Time Position Range . . . . .	4-7
3. Check SEC/DIV Variable Range . . . . .	4-7

Horizontal (cont)	Page
4. Check Delay Time Dial Accuracy . . . . .	4-8
5. Check Delay Jitter . . . . .	4-8
6. Check POSITION Control Range . . . . .	4-8
7. Check X-Gain . . . . .	4-8
8. Check X-Bandwidth . . . . .	4-8

Triggering	Page
1. Check Internal Triggering . . . . .	4-9
2. Check External Triggering . . . . .	4-10

External Z-Axis and Probe Adjust	Page
1. Check EXT Z-AXIS Operation . . . . .	4-12
2. Check PROBE ADJUST Operation . . . . .	4-12

# VERTICAL

## Equipment Required (see Table 4-1):

Calibration Generator (Item 1)	50-Ω BNC Termination (Item 5)
Leveled Sine-Wave Generator (Item 2)	Dual-Input Coupler (Item 6)
50-Ω BNC Cable (Item 4)	

## INITIAL CONTROL SETTINGS

POWER	ON (button in)
<b>CRT</b>	
AUTO INTENSITY	As desired
AUTO FOCUS	Best focused display
<b>Vertical</b>	
POSITION (both)	Midrange
VERTICAL MODE	CH 1
CH 1 VOLTS/DIV	2 mV
CH 2 VOLTS/DIV	10 V
VOLTS/DIV Variable (both)	CAL detent
INVERT	Normal (button out)
AC-GND-DC (both)	DC

<b>Horizontal</b>	
POSITION	Midrange
HORIZONTAL MODE	A
A AND B SEC/DIV	0.5 ms
A AND B SEC/DIV Variable	CAL detent
X10 Magnifier	Off (knob in)

<b>Trigger</b>	
VAR HOLDOFF	NORM
A TRIGGER MODE	AUTO
A TRIGGER SLOPE	∩
A TRIGGER LEVEL	Midrange
A & B INT	VERT MODE
A SOURCE	INT

b. CHECK—Deflection accuracy is within the limits given in Table 4-2 for each CH 1 VOLTS/DIV switch setting and corresponding standard-amplitude signal. When at the 20-mV VOLTS/DIV switch setting, rotate the CH 1 VOLTS/DIV Variable control fully counterclockwise and CHECK that the display decreases to 2 divisions or less. Then return the VOLTS/DIV Variable control to the CAL detent and continue with the 50-mV check.

c. Set the VERTICAL MODE switch to CH 2 and move the cable from the CH 1 OR X input connector to the CH 2 OR Y input connector.

**Table 4-2**  
Deflection Accuracy Limits

VOLTS/DIV Switch Setting	Standard Amplitude Signal	Vertical Deflection (Divisions)	3% Accuracy Limits (Divisions)
2 mV	10 mV	5	4.85 to 5.15
5 mV	20 mV	4	3.88 to 4.12
10 mV	50 mV	5	4.85 to 5.15
20 mV	0.1 V	5	4.85 to 5.15
50 mV	0.2 V	4	3.88 to 4.12
0.1 V	0.5 V	5	4.85 to 5.15
0.2 V	1 V	5	4.85 to 5.15
0.5 V	2 V	4	3.88 to 4.12
1 V	5 V	5	4.85 to 5.15
2 V	10 V	5	4.85 to 5.15
5 V	20 V	4	3.88 to 4.12
10 V	50 V	5	4.85 to 5.15

## PROCEDURE STEPS

### 1. Check Deflection Accuracy and Variable Range

a. Connect a 10-mV standard-amplitude signal to the CH 1 OR X input connector using a 50-Ω cable.

d. CHECK—Deflection accuracy is within the limits given in Table 4-2 for each CH 2 VOLTS/DIV switch setting and corresponding standard-amplitude signal. Perform the checks from the bottom to the top of Table 4-2 to avoid unnecessary switch-position changes. When at the 20-mV VOLTS/DIV switch setting, rotate the CH 2 VOLTS/DIV Variable control fully counterclockwise and CHECK that the display decreases to 2 divisions or less. Then return the VOLTS/DIV Variable control to the CAL detent and finish the check.

e. Disconnect the test setup.

**2. Check Bandwidth**

a. Set:

VOLTS/DIV (both)      2 mV  
 SEC/DIV                      20  $\mu$ s

b. Connect the leveled sine-wave generator output via a 50- $\Omega$  cable and a 50- $\Omega$  termination to the CH 1 OR X input connector.

c. Set the generator output amplitude for a 5-division, 50-kHz display.

d. Change the generator output frequency to the value shown in Table 4-3 for the corresponding VOLTS/DIV switch setting.

**Table 4-3**

**Settings for Bandwidth Checks**

VOLTS/DIV Switch Settings	Generator Output Frequency
2 mV to 10 mV	50 MHz
20 mV to 10 V	60 MHz

e. CHECK—Display amplitude is 3.5 divisions or greater.

f. Repeat parts c through e for all indicated CH 1 VOLTS/DIV switch settings, up to the output-voltage upper limit of the sine-wave generator being used.

g. Move the generator output signal from the CH 1 OR X input connector to the CH 2 OR Y input connector. Set the VERTICAL MODE switch to CH 2.

h. Repeat parts c through e for all indicated CH 2 VOLTS/DIV switch settings, up to the output-voltage upper limit of the sine-wave generator being used.

**3. Check Common-Mode Rejection Ratio**

a. Set both VOLTS/DIV switches to 20 mV.

b. Connect a 10-MHz, leveled sine-wave signal via a 50- $\Omega$  cable, a 50- $\Omega$  termination, and a dual-input coupler to the CH 1 OR X and the CH 2 OR Y input connectors.

c. Set the generator output amplitude to produce a 6-division display.

d. Vertically center the display using the Channel 2 POSITION control. Then set VERTICAL MODE to CH 1 and vertically center the display using the Channel 1 POSITION control.

e. Set the VERTICAL MODE switches to BOTH and ADD; then push in the INVERT button.

f. CHECK—Display amplitude is 0.6 division or less.

g. If the check in part f meets the requirement, skip to part n. If it does not, continue with part h.

h. Set VERTICAL MODE to CH 1.

i. Change the generator frequency to 50 kHz and adjust the output to obtain a 6-division display.

j. Set VERTICAL MODE to BOTH.

k. Adjust the CH 2 VOLTS/DIV Variable control for minimum display amplitude (best CMRR).

l. Change the generator frequency to 10 MHz.

m. CHECK—Display amplitude is 0.6 division or less.

n. Disconnect the test setup.

# HORIZONTAL

## Equipment Required (see Table 4-1):

Calibration Generator (Item 1)	Two 50-Ω BNC Cables (Item 4)
Leveled Sine-Wave Generator (Item 2)	Two 50-Ω BNC Terminations (Item 5)
Time-Mark Generator (Item 3)	

## INITIAL CONTROL SETTINGS

## PROCEDURE STEPS

POWER ON (button in)

### CRT

AUTO INTENSITY As desired  
 AUTO FOCUS Best focused display

### Vertical

Channel 1 POSITION Midrange  
 VERTICAL MODE CH 1  
 CH 1 VOLTS/DIV 0.5 V  
 CH 1 VOLTS/DIV  
 Variable CAL detent  
 INVERT Normal (button out)  
 Channel 1 AC-GND-DC DC  
 Channel 2 AC-GND-DC GND

### Horizontal

POSITION Midrange  
 HORIZONTAL MODE A  
 A AND B SEC/DIV 0.05 μs  
 A AND B SEC/DIV  
 Variable CAL detent  
 X10 Magnifier Off (knob in)  
 B DELAY TIME  
 POSITION Fully counterclockwise

### Trigger

VAR HOLDOFF NORM  
 A TRIGGER MODE NORM  
 SLOPE (both)  $\int$   
 LEVEL (both) Midrange  
 A & B INT VERT MODE  
 A SOURCE EXT  
 A EXT COUPLING DC÷10

### 1. Check Timing Accuracy

a. Connect 50-ns time markers from the time-mark generator via a 50-Ω cable and a 50-Ω termination to the CH 1 OR X input connector. Connect the generator Trigger output via a 50-Ω cable and a 50-Ω termination to the EXT INPUT connector.

b. Use the Channel 1 POSITION control to center the trace vertically. Adjust the A TRIGGER LEVEL control for a stable, triggered display.

c. Use the Horizontal POSITION control to align the first time marker that is 50 ns beyond the start of the sweep with the 2nd vertical graticule line.

### NOTE

*When making timing measurements, use as a reference the same point on each time marker.*

d. CHECK—Timing accuracy is within the limits shown in Table 4-4 for the applicable position of the X10 Magnifier. When making the check with the X10 Magnifier On, exclude any portion of the sweep past the 100th magnified division.

Table 4-4

A and B Timing Accuracy

X10 Magnifier	Accuracy at 10th Vertical Graticule Line
Off (knob in)	3% (0.24 division)
On (knob out)	5% (0.40 division)

e. Set the HORIZONTAL MODE switch to B and adjust the B TRIGGER LEVEL control for a stable display.

f. Align the first time marker that is 50 ns beyond the start of the sweep with the 2nd vertical graticule line, using the Horizontal POSITION control.

g. CHECK—Timing accuracy is within the limits shown in Table 4-4 for the applicable position of the X10 Magnifier. When making the check with the X10 Magnifier On, exclude any portion of the sweep past the 100th magnified division.

h. Set the HORIZONTAL MODE switch to A.

i. Repeat parts b through h for the A and B SEC/DIV and time-mark generator setting combinations shown in Table 4-5 under the "Normal" column.

j. Set:

A and B SEC/DIV                    0.05  $\mu$ s  
X10 Magnifier                        On (knob out)

k. Select 10-ns time markers from the time-mark generator.

l. Repeat parts b through h for the A and B SEC/DIV and time-mark generator setting combinations shown in Table 4-5 under the "X10 Magnified" column.

## 2. Check Delay Time Position Range

a. Set:

Channel 1 AC-GND-DC            GND  
HORIZONTAL MODE                ALT  
A AND B SEC/DIV                 0.2 ms

b. Align the start of the A sweep with the 1st vertical graticule line.

c. CHECK—Intensified portion of the trace starts within 0.5 division of the start of the sweep.

d. Rotate the B DELAY TIME POSITION control fully clockwise.

e. CHECK—Intensified zone is past the 11th vertical graticule line.

## 3. Check SEC/DIV Variable Range

a. Set:

CH 1 VOLTS/DIV                    0.5 V  
Channel 1 AC-GND-DC            DC  
HORIZONTAL MODE                A  
A SEC/DIV                            0.2 ms  
SEC/DIV Variable                 Fully counterclockwise  
X10 Magnifier                       Off (knob in)

b. Select 0.5-ms time markers from the time-mark generator.

c. CHECK—Time markers are 1 division or less apart.

d. Return the SEC/DIV Variable control to the CAL detent.

Table 4-5

Settings for Timing Accuracy Checks

A AND B SEC/DIV Switch Setting	Time-Mark Generator Output	
	Normal	X10 Magnified
0.05 $\mu$ s	50 ns	10 ns
0.1 $\mu$ s	0.1 $\mu$ s	10 ns
0.2 $\mu$ s	0.2 $\mu$ s	20 ns
0.5 $\mu$ s	0.5 $\mu$ s	50 ns
1 $\mu$ s	1 $\mu$ s	0.1 $\mu$ s
2 $\mu$ s	2 $\mu$ s	0.2 $\mu$ s
5 $\mu$ s	5 $\mu$ s	0.5 $\mu$ s
10 $\mu$ s	10 $\mu$ s	1 $\mu$ s
20 $\mu$ s	20 $\mu$ s	2 $\mu$ s
50 $\mu$ s	50 $\mu$ s	5 $\mu$ s
0.1 ms	0.1 ms	10 $\mu$ s
0.2 ms	0.2 ms	20 $\mu$ s
0.5 ms	0.5 ms	50 $\mu$ s
1 ms	1 ms	0.1 ms
2 ms	2 ms	0.2 ms
5 ms	5 ms	0.5 ms
10 ms	10 ms	1 ms
20 ms	20 ms	2 ms
50 ms	50 ms	5 ms
<b>A Sweep Only</b>		
0.1 s	0.1 s	10 ms
0.2 s	0.2 s	20 ms
0.5 s	0.5 s	50 ms



#### 4. Check Delay Time Dial Accuracy

a. Set:

HORIZONTAL MODE	B
A SEC/DIV	0.2 $\mu$ s
B SEC/DIV	0.05 $\mu$ s
B TRIGGER LEVEL	CW-RUN AFTER DLY

b. Select 0.2- $\mu$ s time markers.

c. Set the B DELAY TIME POSITION control to 1.00. Adjust the Horizontal POSITION control so that the top of the first fully displayed time marker is aligned with the center vertical graticule line.

d. Without changing the Horizontal POSITION control setting, set the B DELAY TIME POSITION dial setting to 9.00. Slightly readjust the B DELAY TIME POSITION control to align the top of the time marker with the center vertical graticule line.

e. CHECK—The B DELAY TIME POSITION dial setting is between 8.87 and 9.14.

f. Set:

A SEC/DIV	0.5 ms
B SEC/DIV	50 $\mu$ s

g. Select 0.5- $\mu$ s time markers.

h. Repeat parts c through e.

#### 5. Check Delay Jitter

a. Set the B SEC/DIV switch to 0.5  $\mu$ s.

b. Select 10- $\mu$ s time markers.

c. Slightly readjust the B DELAY TIME POSITION dial to position a time marker within the graticule area.

d. CHECK—Jitter on the leading edge of the time marker does not exceed 1 division. Disregard slow drift.

#### 6. Check POSITION Control Range

a. Set:

A SEC/DIV	10 $\mu$ s
HORIZONTAL MODE	A

b. Select 50- $\mu$ s time markers.

c. Align the 3rd time marker with the center vertical graticule line.

d. Set the X10 Magnifier knob to On (knob out).

e. CHECK—Magnified time marker can be positioned to the left of the center vertical graticule line by rotating the Horizontal POSITION control fully counterclockwise.

f. CHECK—Start of the sweep can be positioned to the right of the center vertical graticule line by rotating the Horizontal POSITION control fully clockwise.

g. Disconnect the test setup.

#### 7. Check X-Gain

a. Set:

CH 1 VOLTS/DIV	20 mV
A SEC/DIV	X-Y

b. Connect a 0.1-V standard-amplitude signal to the CH 1 OR X input connector using a 50- $\Omega$  cable.

c. CHECK—Display is 5 divisions  $\pm$ 0.25 division (4.75 to 5.25 divisions).

d. Disconnect the test setup.

#### 8. Check X-Bandwidth

a. Connect a 50-kHz leveled sine-wave signal via a 50- $\Omega$  cable and a 50- $\Omega$  termination to the CH 1 OR X input connector.

b. Set the generator to obtain a 5-division horizontal display.

c. Adjust the generator output frequency to 2 MHz.

d. CHECK—Display is at least 3.5 divisions in length.

e. Disconnect the test setup.

# TRIGGERING

## Equipment Required (see Table 4-1):

Leveled Sine-Wave Generator (Item 2)	BNC T-Connector (Item 8)
50- $\Omega$ BNC Cable (Item 4)	Probe-tip-to-BNC Adapter (Item 9)
50- $\Omega$ BNC Termination (Item 5)	P6120 Probe (provided with instrument)
10X Attenuator (Item 7)	

## INITIAL CONTROL SETTINGS

POWER ON (button in)

### CRT

AUTO INTENSITY As desired  
 AUTO FOCUS Best focused display

### Vertical

POSITION (both) Midrange  
 VERTICAL MODE CH 1  
 CH 1 VOLTS/DIV 2 mV  
 CH 2 VOLTS/DIV 20 mV  
 VOLTS/DIV Variable  
 (both) CAL detent  
 INVERT Normal (button out)  
 AC-GND-DC (both) DC

### Horizontal

POSITION Midrange  
 HORIZONTAL MODE A  
 A AND B SEC/DIV 0.2  $\mu$ s  
 A AND B SEC/DIV  
 Variable CAL detent  
 X10 Magnifier Off (knob in)

### Trigger

VAR HOLDOFF NORM  
 A TRIGGER MODE NORM  
 SLOPE (both)   
 LEVEL (both) Midrange  
 A & B INT VERT MODE  
 A SOURCE INT  
 A EXT COUPLING DC

## PROCEDURE STEPS

### 1. Check Internal Triggering

a. Connect the leveled sine-wave generator output via a 50- $\Omega$  cable and a 50- $\Omega$  termination to the CH 1 OR X input connector.





b. Set the generator output to produce a 4-division, 2-MHz display.

c. Set the CH 1 VOLTS/DIV switch to 20 mV.

d. CHECK—Stable display can be obtained by adjusting the A TRIGGER LEVEL control for each switch combination given in Table 4-6.

Table 4-6

Switch Combinations for A Triggering Checks

TRIGGER MODE	TRIGGER SLOPE
NORM	
NORM	
AUTO	
AUTO	

e. Set the HORIZONTAL MODE switch to B.

f. CHECK—Stable display can be obtained by adjusting the B TRIGGER LEVEL control for both positive- and negative-going positions of the B TRIGGER SLOPE switch.

**Performance Check Procedure—2215 Service**

g. Set:

VERTICAL MODE CH 2  
HORIZONTAL MODE A

h. Move the generator output from the CH 1 OR X input connector to the CH 2 OR Y input connector. Set VERTICAL MODE to CH 2.

i. Repeat parts d through f.

j. Set:

HORIZONTAL MODE A  
A SEC/DIV 0.05  $\mu$ s

k. Set the generator to produce a 1.5-division, 60-MHz display.

l. Repeat part d.

m. Move the generator output from the CH 2 OR Y input connector to the CH 1 OR X input connector. Set VERTICAL MODE to CH 1.

n. Repeat part d.

o. Adjust the generator output and the A TRIGGER LEVEL control for a stable, 2-division display.

p. Repeat parts e and f.

q. Move the generator output from the CH 1 OR X input connector to the CH 2 OR Y input connector. Set VERTICAL MODE to CH 2.

r. Repeat part f.

s. Disconnect the test setup.

**2. Check External Triggering**

a. Set:

VOLTS/DIV 10 mV  
A SEC/DIV 10  $\mu$ s  
VERTICAL MODE CH 1

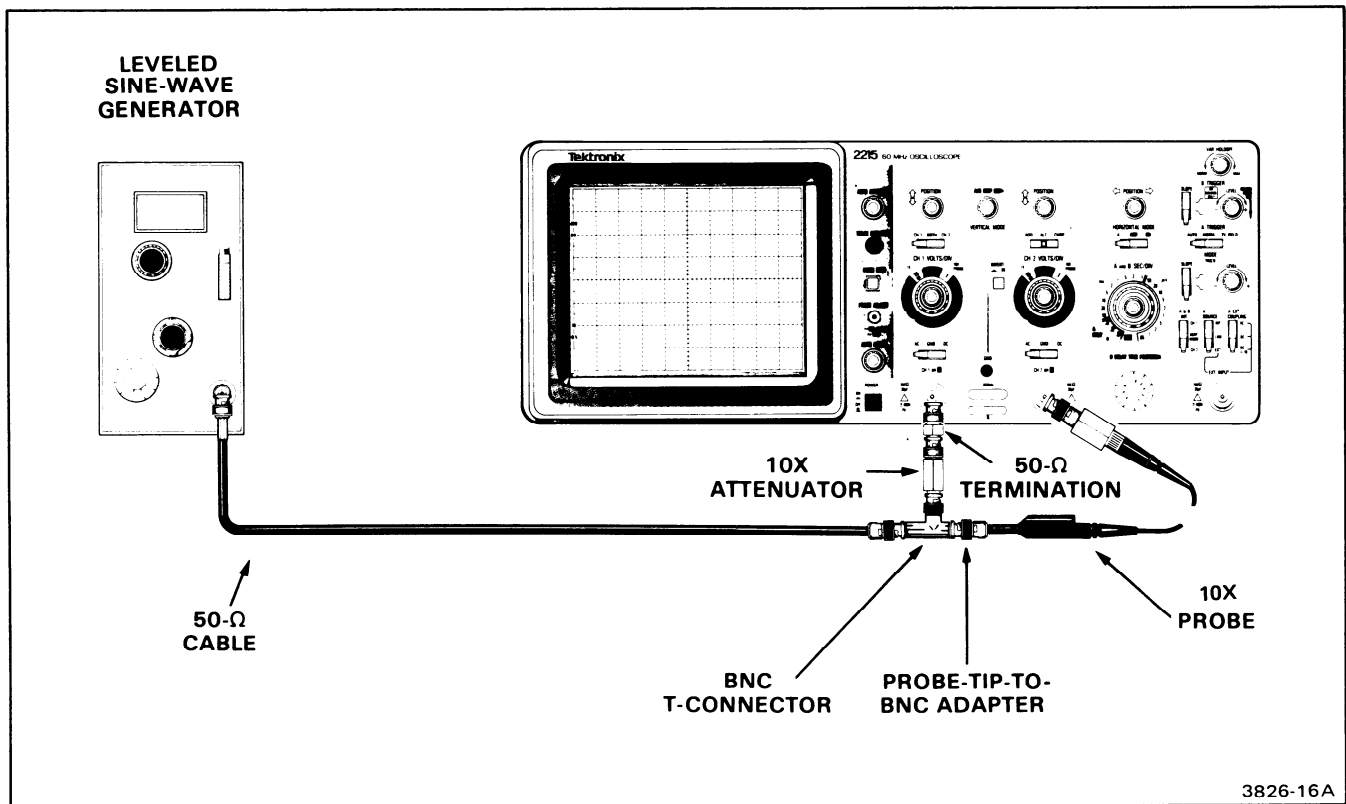

Figure 4-1. Test setup for external trigger and jitter checks.

b. Connect the test setup as shown in Figure 4-1.

c. Set the leveled sine-wave generator to produce a 5-division, 50-kHz display.

d. Set:

VERTICAL MODE	CH 2
A SEC/DIV	0.2 $\mu$ S
A SOURCE	EXT

e. Move the signal from the CH 1 OR X input connector to the EXT INPUT connector.

f. Set the generator to 2 MHz.

g. CHECK—Stable display can be obtained by adjusting the A TRIGGER LEVEL control for each switch combination given in Table 4-6.

h. Remove the 10X attenuator from the test setup and set the A EXT COUPLING switch to DC÷10.

i. Repeat part g.

j. Set:

VOLTS/DIV (both)	50 mV
VERTICAL MODE	CH 2
A SEC/DIV	20 $\mu$ S
A SOURCE	INT

k. Reconnect the test setup as shown in Figure 4-1.

l. Set the leveled sine-wave generator to produce a 5-division, 50-kHz display.

m. Set:

VERTICAL MODE	CH 2
A SEC/DIV	0.05 $\mu$ S
X10 Magnifier	On (knob out)
A SOURCE	EXT

n. Repeat part e.

o. Set the generator to 60 MHz.

p. Repeat parts g and h.

q. Repeat part g.

r. Disconnect the test setup.

# EXTERNAL Z-AXIS AND PROBE ADJUST

## Equipment Required (see Table 4-1):

Leveled Sine-Wave Generator (Item 2)

BNC T-Connector (Item 8)

Two 50-Ω BNC Cables (Item 4)

P6120 Probe (provided with instrument)

## INITIAL CONTROL SETTINGS

POWER ON

### CRT

AUTO INTENSITY As desired  
 AUTO FOCUS Best defined display

### Vertical

Channel 1 POSITION Midrange  
 VERTICAL MODE CH 1  
 CH 1 VOLTS/DIV 2 V  
 CH 1 VOLTS/DIV  
 Variable CAL detent  
 Channel 1 AC-GND-DC DC

### Horizontal

POSITION Midrange  
 HORIZONTAL MODE A  
 A SEC/DIV 20 μs  
 A AND B SEC/DIV  
 Variable CAL detent

### Trigger

VAR HOLDOFF NORM  
 A TRIGGER MODE AUTO  
 A TRIGGER SLOPE   
 A TRIGGER LEVEL Midrange  
 A & B INT VERT MODE  
 A SOURCE INT

## PROCEDURE STEPS

### 1. Check EXT Z-AXIS Operation

a. Connect the leveled sine-wave generator output via a T-connector and two 50-Ω cables to the EXT Z-AXIS INPUT connector on the rear panel and to the CH 1 OR X input connector.

b. Adjust the generator controls to produce a 5-volt, 50 kHz display.

c. CHECK—For noticeable intensity modulation. The positive part of the sine wave should be of lower intensity than the negative part.

d. Disconnect the test setup.

### 2. Check PROBE ADJUST Operation

a. Set:

CH 1 VOLTS/DIV 10 mV  
 A SEC/DIV 0.5 ms

b. Connect the P6120 Probe to the CH 1 OR X input connector and insert the probe tip into the PROBE ADJUST jack on the instrument front panel. If necessary, adjust the probe compensation for a flat-topped square-wave display.

c. CHECK—Display is 5 divisions ±1 division (4 to 6 divisions).

d. Disconnect the test setup.

# ADJUSTMENT PROCEDURE

## INTRODUCTION

### IMPORTANT—PLEASE READ BEFORE USING THIS PROCEDURE

#### PURPOSE

The “Adjustment Procedure” is used to return the instrument to conformance with its “Performance Requirements” as listed in the “Specification” (Section 1). These adjustments should be performed only after the checks in the “Performance Check Procedure” (Section 4) have indicated a need for adjustment of the instrument.

#### TEST EQUIPMENT REQUIRED

The test equipment listed in Table 4-1 is a complete list of the equipment required to accomplish both the “Adjustment Procedure” in this section and the “Performance Check Procedure” in Section 4. Test equipment specifications described in Table 4-1 are the minimum necessary to provide accurate results. Therefore, equipment used must meet or exceed the listed specifications. Detailed operating instructions for test equipment are not given in this procedure. If more operating information is required, refer to the appropriate test equipment instruction manual.

When equipment other than that recommended is used, control settings of the test setup may need to be altered. If the exact item of equipment given as an example in Table 4-1 is not available, first check the “Purpose” column to verify use of this item. Then use the “Minimum Specification” column to determine if any other available test equipment might suffice.

#### LIMITS AND TOLERANCES

The limits and tolerances stated in this procedure are instrument specifications only if they are listed in the “Performance Requirements” column of the “Specification” (Section 1). Tolerances given are applicable only to the instrument undergoing adjustment and do not include test equipment error. Adjustment of the instrument must

be accomplished at an ambient temperature between +20°C and +30°C, and the instrument must have had a warm-up period of at least 20 minutes.

#### PARTIAL PROCEDURES

This procedure is structured in subsections to permit adjustment of individual sections of the instrument (except the Power Supply) whenever a complete readjustment is not required. For example, if only the Vertical section fails to meet the Performance Requirements (or has had repairs made or components replaced), it can be readjusted with little or no effect on other sections of the instrument. However, if the Power Supply section has undergone repairs or adjustments that change the absolute value of any of the supply voltages, a complete readjustment of the instrument may be required.

At the beginning of each subsection is a list of all the front-panel control settings required to prepare the instrument for performing Step 1 in that subsection. Each succeeding step within a subsection should then be performed both in the sequence presented and in its entirety to ensure that control settings will be correct for ensuing steps.

#### ADJUSTMENT INTERACTION

The use of Table 5-1 is particularly important if a partial procedure is performed or if a circuit requires readjustment due to a component replacement. To use this table, first find the adjustment that was made (extreme left column). Then move to the right, across the row, until you come to a darkened square. From the darkened square, move up the table to find the affected adjustment at the heading of that column. Check the accuracy of this adjustment and, if necessary, perform readjustment.

**Table 5-1  
Adjustment Interactions**

Adjustments or Replacements Made	Adjustments Affected																										
	-8.6V ADJ	HEAD ROOM VOLTAGE	TRACE ROTATION	GRID BIAS	ASTIG	AUTO FOCUS ADJ	GEOMETRY	VERTICAL GAIN	ATTENUATOR STEP BALANCE	ATTENUATOR X10 BALANCE	INVERT BALANCE	CH 1/CH 2 BALANCE	ATTENUATOR COMP	VERTICAL OUTPUT COMP	CH 1 & CH 2 HF MATCH	HORIZ GAIN	HORIZ B GAIN	HORIZ X10 GAIN	MAG REGISTRATION	DELAY DIAL START ADJ	DELAY DIAL GAIN	5 $\mu$ s TIMING (A AND B)	HIGH SPEED TIMING	X GAIN	SLOPE BALANCE	AUTO TRIGGER CENTERING	
-8.6V ADJ	■																										
HEAD ROOM VOLTAGE	■																										
TRACE ROTATION		■																									
GRID BIAS			■																								
ASTIG				■																							
AUTO FOCUS ADJ					■																						
GEOMETRY						■																					
VERTICAL GAIN							■																				
ATTENUATOR STEP BALANCE								■																			
ATTENUATOR X10 BALANCE									■																		
INVERT BALANCE										■																	
CH 1/CH 2 BALANCE											■																
ATTENUATOR COMP												■															
VERTICAL OUTPUT COMP													■														
CH 1 & CH 2 HF MATCH														■													
HORIZ GAIN															■												
HORIZ B GAIN																■											
HORIZ X10 GAIN																	■										
MAG REGISTRATION																		■									
DELAY DIAL START ADJ																			■								
DELAY DIAL GAIN																				■							
5 $\mu$ s TIMING (A AND B)																					■						
HIGH SPEED TIMING																						■					
X GAIN																							■				
SLOPE BALANCE																								■			
AUTO TRIGGER CENTERING																									■		
CRT REPLACEMENT		■	■	■	■	■	■	■	■	■	■	■	■	■	■	■	■	■	■	■	■	■	■	■	■	■	■

3826-43

Specific interactions are also called out within certain adjustment steps to indicate that adjustments must be repeated until no further improvement is noted.

## PREPARATION FOR ADJUSTMENT

It is necessary to remove the instrument cabinet to perform the Adjustment Procedure. See the "Cabinet" removal instructions located in the "Maintenance" section of the manual.

Before performing this procedure, do not preset any internal controls and do not change the  $-8.6\text{-V}$  Power-Supply adjustment, since that will typically necessitate a complete readjustment of the instrument, when only a partial readjustment might otherwise be required. To avoid unnecessary readjustment, only change an internal control setting whenever a Performance Characteristic cannot be met with the original setting. If it is necessary to change the setting of any internal control, always check Table 5-1 for possible interacting adjustments that might be required.

All test equipment items described in Table 4-1 are required to accomplish a complete Adjustment Procedure. At the beginning of each subsection there is an equipment-required list showing only the test equipment necessary for performing the steps in that subsection. In this list, the item number following each piece of equipment corresponds to the item number listed in Table 4-1.

Make initial control settings as listed at the beginning of each subsection. Then connect the test equipment to an appropriate ac-power-input source and connect the 2215 to a variable autotransformer (Item 10 in Table 4-1) that is set for 115 V ac. Apply power and allow a 20-minute warm-up period before commencing any adjustments.

The most accurate display adjustments are made with a stable, well-focused, low-intensity display. Unless otherwise noted, adjust the AUTO INTENSITY, AUTO FOCUS, and TRIGGER LEVEL controls as needed to view the display.

Wherever possible in this procedure, instrument performance is first checked before an adjustment is made. Steps containing both checks and adjustments are titled "Check/Adjust." Those steps with only checks are titled "Check."

## INDEX TO ADJUSTMENT PROCEDURE

	Page
<b>Power Supply and CRT Display</b>	
1. Check/Adjust Power Supply DC Levels and Ripple . . . . .	5-4
2. Check High-Voltage Supply . . . . .	5-5
3. Check/Adjust CRT Grid Bias . . . . .	5-5
4. Adjust Astigmatism and Auto Focus Tracking. . . . .	5-5
5. Check/Adjust Trace Alignment (TRACE ROTATION) . . . . .	5-5
6. Adjust Geometry . . . . .	5-6
<b>Vertical</b>	
1. Adjust Vertical Gain . . . . .	5-7
2. Adjust Attenuator Step Balance . . . . .	5-8
3. Adjust Attenuator X10 Balance . . . . .	5-8
4. Check Deflection Accuracy and Variable Range . . . . .	5-8
5. Check Input Coupling . . . . .	5-9
6. Check ALT and CHOP Operation . . . . .	5-9
7. Check VOLTS/DIV Variable Control Trace Shift. . . . .	5-9
8. Adjust Invert Balance . . . . .	5-9
9. Adjust Trigger Balance . . . . .	5-9
10. Adjust Attenuator Compensation . . . . .	5-10
11. Adjust Vertical Output Amplifier Compensation . . . . .	5-10
12. Adjust Channel Matching and Check Bandwidth . . . . .	5-11
13. Check Common-Mode Rejection Ratio . . . . .	5-11
14. Check POSITION Control Range . . . . .	5-12
15. Check Channel Isolation . . . . .	5-12
<b>Horizontal</b>	
1. Adjust Horizontal Amplifier Gain . . . . .	5-13
2. Adjust Magnifier Registration . . . . .	5-13
3. Adjust Delay Dial Timing . . . . .	5-14
4. Adjust 5- $\mu\text{s}$ Timing . . . . .	5-14
5. Adjust High-Speed Timing. . . . .	5-14
6. Check Timing Accuracy . . . . .	5-15
7. Check B DELAY TIME POSITION Control Range . . . . .	5-16
8. Check SEC/DIV Variable Range. . . . .	5-16
9. Check B DELAY TIME POSITION Dial Accuracy . . . . .	5-16
10. Check Delay Jitter. . . . .	5-16
11. Check POSITION Control Range . . . . .	5-16
12. Adjust X-Gain. . . . .	5-17
13. Check X-Bandwidth. . . . .	5-17
<b>Triggering</b>	
1. Adjust Trigger Slope Balance . . . . .	5-18
2. Check/Adjust Auto Trigger Centering and TRIG'D LED Operation . . . . .	5-18
3. Check Internal Triggering . . . . .	5-19
4. Check External Triggering. . . . .	5-19
<b>External Z-Axis and Probe Adjust</b>	
1. Check EXT Z-AXIS Operation. . . . .	5-21
2. Check PROBE ADJUST Operation. . . . .	5-21



# POWER SUPPLY AND CRT DISPLAY

## Equipment Required (see Table 4-1)

Leveled Sine-Wave Generator (Item 2)	Digital Voltmeter (Item 11)
Time-Mark Generator (Item 3)	Test Oscilloscope and 1X Probe (Item 12)
50-Ω BNC Cable (Item 4)	DC Voltmeter (Item 13)
50-Ω BNC Termination (Item 5)	Screwdriver (Item 14)
Variable Autotransformer (Item 10)	

See

### ADJUSTMENT LOCATIONS 1

at the back of this manual for location of test points and adjustments.

### NOTE

Before applying power to the 2215, make the initial control settings. Connect the 2215 to an appropriate power source through a variable autotransformer, adjusted for an output of 115 V. Apply power to both the instrument and the test equipment and allow a 20-minute warm-up period before commencing the adjustments and checks.

## INITIAL CONTROL SETTINGS

### CRT

AUTO INTENSITY	As desired
AUTO FOCUS	Best focused display

### Vertical (both)

POSITION	Midrange
VERTICAL MODE	CH 1
VOLTS/DIV	0.1 V
VOLTS/DIV Variable	CAL detent
AC-GND-DC	GND

### Horizontal

POSITION	Midrange
HORIZONTAL MODE	A
A SEC/DIV	5 μs
A AND B SEC/DIV Variable	CAL detent
X10 Magnifier	Off (knob in)

### Trigger

VAR HOLDOFF	NORM
A TRIGGER MODE	TV FIELD
A TRIGGER SLOPE	∩
A TRIGGER LEVEL	Midrange
A & B INT	VERT MODE
A SOURCE	INT

## PROCEDURE STEPS

### 1. Check/Adjust Power Supply DC Levels and Ripple (R946 and R952)

#### NOTE

Review the information at the beginning of the Adjustment Procedure before starting this step.

a. Remove the High-Voltage shield (see the "High-Voltage Shield" removal procedure in Section 6).

#### WARNING

When checking the Head Room Voltage, use a digital voltmeter that is isolated from ground, because the inverter power-supply circuitry common is at line potential.

b. Connect the digital voltmeter low lead to common (TP934) and connect the volts lead to TP952.

c. CHECK—Reading is +4.2 V to +4.4 V. If the reading is within these limits, skip to part e.

d. ADJUST—Head Room Voltage Adjust (R952) for +4.3 V.

e. Disconnect the voltmeter leads.

f. Connect the digital voltmeter low lead to chassis ground (TP501) and connect the volts lead to the -8.6-V supply (TP500).

g. CHECK—Reading is  $-8.64\text{ V}$  to  $-8.56\text{ V}$ . If the reading is within these limits, skip to part i.

h. ADJUST—The  $-8.6\text{-V}$  Adj (R946) for  $-8.6\text{ V}$ .

i. Replace the High-Voltage shield (see the “High-Voltage Shield” reinstallation procedure in Section 6).

j. CHECK—Voltage levels of the remaining power supplies listed in Table 5-2 are within their specified limits.

**Table 5-2**  
**Power Supply Limits and Ripple**

Power Supply	Test Point	Reading (Volts)	P-P Ripple (mV)
$-8.6\text{ V}$	TP500	$-8.56$ to $-8.64$	$<10$
$+5\text{ V}$	W985	$4.75$ to $5.25$	$<10$
$+8.6\text{ V}$	W975	$8.34$ to $8.86$	$<10$
$+30\text{ V}$	W965	$28.5$ to $31.5$	$<50$
$+100\text{ V}$	W966	$95$ to $105$	$<200$

k. Connect the test oscilloscope, using a 1X probe, to the first test point indicated in Table 5-2 and connect the probe ground lead to TP501.

l. CHECK—Ripple amplitude of the dc supply is within the typical value given in Table 5-2.

m. Repeat parts k and l for each test point in Table 5-2.

n. Disconnect the test setup.

## 2. Check High-Voltage Supply

a. Set the POWER switch to OFF (button out).

b. Set the dc voltmeter to a range of at least  $-2500\text{ V}$  dc and connect the volts lead to chassis ground. Remove the crt base-socket cover and connect the common lead of the dc voltmeter to pin 2 on the socket.

c. Set the POWER switch to ON (button in).

d. CHECK—High Voltage Supply dc level is  $-1900\text{ V}$  to  $-2100\text{ V}$ .

e. Set the POWER switch to OFF (button out).

f. Disconnect the voltmeter leads and re-install the crt base-socket cover.

g. Set the POWER switch to ON (button in).

## 3. Adjust CRT Grid Bias (R860)

a. Set the A SEC/DIV switch to X-Y.

b. Rotate the AUTO INTENSITY control fully counter-clockwise.

c. Connect a  $50\text{-}\Omega$  termination to the EXT Z AXIS INPUT connector located on the rear panel.

d. ADJUST—Both the Grid Bias adjustment (R860) and the AUTO FOCUS control for a visible dot. Then back off the Grid Bias potentiometer until the dot just disappears.

e. Disconnect the test setup.

## 4. Adjust Astigmatism and Auto Focus Tracking (R887 and R875)

a. Set:

Channel 1 AC-GND-DC	DC
A SEC/DIV	$20\ \mu\text{s}$
A TRIGGER MODE	AUTO

b. Connect a leveled sine-wave generator via a  $50\text{-}\Omega$  cable and a  $50\text{-}\Omega$  termination to the CH 1 OR X input connector.

c. Adjust the generator output for a 4-division, 50-kHz display.

## Adjustment Procedure—2215 Service

d. ADJUST—Both the Astig adjustment (R887) and the AUTO FOCUS control for the best focused display over the range of the AUTO INTENSITY control.

e. Set the A SEC/DIV switch to 5  $\mu$ s.

f. ADJUST—Auto Focus Adj (R875) for the best focused display. Do not change the front panel AUTO FOCUS control.

g. Disconnect the test setup.

### 5. Check/Adjust Trace Alignment (TRACE ROTATION)

a. Set the Channel 1 AC-GND-DC switch to GND.

b. CHECK—That the trace is parallel to the center horizontal graticule line.

c. ADJUST—The front-panel TRACE ROTATION control to align the trace with the center horizontal graticule line.

### 6. Adjust Geometry (R870)

a. Set:

CH 1 VOLTS/DIV	50 mV
Channel 1 AC-GND-DC	DC

b. Connect 50- $\mu$ s time markers from the time-mark generator via a 50- $\Omega$  cable and a 50- $\Omega$  termination to the CH 1 OR X input connector.

c. Adjust the A AND B SEC/DIV Variable control for 5 markers per division.

d. ADJUST—Geom (R870) for minimum curvature of the markers across the graticule area.

e. Disconnect the test setup.

# VERTICAL

## Equipment Required (see Table 4-1):

Calibration Generator (Item 1)	Adapter (Item 9)
Leveled Sine-Wave Generator (Item 2)	Digital Voltmeter (Item 11)
50- $\Omega$ BNC Cable (Item 4)	1X Probe (Item 12)
50- $\Omega$ BNC Termination (Item 5)	Screwdriver (Item 14)
Dual-Input Coupler (Item 6)	Low-Capacitance Alignment Tool (Item 15)
10X Attenuator (Item 7)	P6120 Probe (Included with instrument)

See

 ADJUSTMENT LOCATIONS 1

and

 ADJUSTMENT LOCATIONS 2

at the back of this manual for locations of test points and adjustments.

## INITIAL CONTROL SETTINGS

POWER	ON (button in)
<b>CRT</b>	
AUTO INTENSITY	As desired
AUTO FOCUS	Best focused display
<b>Vertical (both)</b>	
POSITION	Midrange
VERTICAL MODE	CH 1
VOLTS/DIV	20 mV
VOLTS/DIV Variable	CAL detent
INVERT	Normal (button out)
AC-GND-DC	DC
<b>Horizontal</b>	
POSITION	Midrange
HORIZONTAL MODE	A
A AND B SEC/DIV	0.5 ms
A AND B SEC/DIV Variable	CAL detent
X10 Magnifier	Off (knob in)
<b>Trigger</b>	
VAR HOLDOFF	NORM
A TRIGGER MODE	AUTO
A TRIGGER SLOPE	$\int$
A TRIGGER LEVEL	Midrange
A & B INT	VERT MODE
A SOURCE	INT

## PROCEDURE STEPS

### 1. Adjust Vertical Gain (R186, R286, R145, and R245)

a. Connect a 100-mV standard-amplitude signal via a 50- $\Omega$  cable to the CH 1 OR X input connector.

b. ADJUST—Ch 1 Gain (R186) for an exact 5-division display.

c. Move the cable from the CH 1 OR X input connector to the CH 2 OR Y input connector. Change the VERTICAL MODE switch to CH 2.

d. ADJUST—Ch 2 Gain (R286) for an exact 5-division display.

e. Change the generator output to 10 mV and set the CH 1 and CH 2 VOLTS/DIV switches to 2 mV.

f. ADJUST—Ch 2 X10 Vert Gain (R245) for an exact 5-division display.

g. Move the cable from the CH 2 OR Y input connector to the CH 1 OR X input connector. Change the VERTICAL MODE switch to CH 1.

h. ADJUST—Ch 1 X10 Vert Gain (R145) for an exact 5-division display.

**2. Adjust Attenuator Step Balance (R138 and R238)**

- a. Set both AC-GND-DC switches to GND.
- b. Set the CH 1 VOLTS/DIV switch to 10 mV and position the trace on the center horizontal graticule line using the Channel 1 POSITION control.
- c. Change the CH 1 VOLTS/DIV switch to 2 mV.
- d. ADJUST—Ch 1 Step Bal (R138) to set the trace on the center horizontal graticule line.
- e. Repeat parts b through d until there is no trace shift when changing the CH 1 VOLTS/DIV switch from 10 mV to 2 mV.
- f. Change the VERTICAL MODE switch to CH 2.
- g. Repeat parts b through e for Channel 2, adjusting Ch 2 Step Bal (R238) in step d.

**3. Adjust Attenuator X10 Balance (R146 and R246)**

- a. Set the CH 2 VOLTS/DIV switch to 20 mV.
- b. Position the trace on the center horizontal graticule line using the Channel 2 POSITION control.
- c. Change the CH 2 VOLTS/DIV switch to 10 mV.
- d. ADJUST—Ch 2 X10 Bal (R246) to set the trace on the center horizontal graticule line.
- e. Repeat parts a through d until there is no trace shift when changing the CH 2 VOLTS/DIV switch from 20 mV to 10 mV.
- f. Change the VERTICAL MODE switch to CH 1.
- g. Repeat parts a through e for Channel 1, adjusting Ch 1 X10 Bal (R146) in step d.

**4. Check Deflection Accuracy and Variable Range**

a. Set:

CH 1 VOLTS/DIV	2 mV
CH 2 VOLTS/DIV	10 V
AC-GND-DC (both)	DC

b. CHECK—Deflection accuracy is within the limits given in Table 5-3 for each CH 1 VOLTS/DIV switch setting and corresponding standard-amplitude signal. When at the 20-mV VOLTS/DIV switch setting, rotate the CH 1 VOLTS/DIV Variable control fully counterclockwise and CHECK that the display decreases to 2 divisions or less. Then return the VOLTS/DIV Variable control to the CAL detent and continue with the 50-mV check.

**Table 5-3**

**Deflection Accuracy Limits**

VOLTS/DIV Switch Setting	Standard Amplitude Signal	Vertical Deflection (Divisions)	3% Accuracy Limits (Divisions)
2 mV	10 mV	5	4.85 to 5.15
5 mV	20 mV	4	3.88 to 4.12
10 mV	50 mV	5	4.85 to 5.15
20 mV	0.1 V	5	4.85 to 5.15
50 mV	0.2 V	4	3.88 to 4.12
0.1 V	0.5 V	5	4.85 to 5.15
0.2 V	1 V	5	4.85 to 5.15
0.5 V	2 V	4	3.88 to 4.12
1 V	5 V	5	4.85 to 5.15
2 V	10 V	5	4.85 to 5.15
5 V	20 V	4	3.88 to 4.12
10 V	50 V	5	4.85 to 5.15

c. Set the VERTICAL MODE switch to CH 2 and move the cable from the CH 1 OR X input connector to the CH 2 OR Y input connector.

d. CHECK—Deflection accuracy is within the limits given in Table 5-3 for each CH 2 VOLTS/DIV switch setting and corresponding standard-amplitude signal. Perform the checks from the bottom to the top of Table 5-3 to avoid unnecessary switch-position changes. When at the 20-mV VOLTS/DIV switch setting, rotate the CH 2 VOLTS/DIV Variable control fully counterclockwise and CHECK that the display decreases to 2 divisions or less.

Then return the VOLTS/DIV Variable control to the CAL detent and finish the check.

## 5. Check Input Coupling

- a. Set both VOLTS/DIV switches to 50-mV.
- b. Set the calibration generator to produce a 200-mV standard-amplitude signal.
- c. Position the bottom of the signal on the center horizontal graticule line using the Channel 2 POSITION control.
- d. Set the Channel 2 input coupling switch to AC.
- e. CHECK—Display is centered about the center horizontal graticule line.
- f. Set the VERTICAL MODE switch to CH 1 and move the input signal from the CH 2 OR Y input connector to the CH 1 OR X input connector.
- g. Repeat parts c through e for Channel 1.

## 6. Check ALT and CHOP Operation

- a. Set:

VERTICAL MODE	BOTH-ALT
AC-GND-DC (both)	GND
A SEC/DIV	10 ms

- b. CHECK—Display alternates between the CH 1 and CH 2 displays. If necessary, use both POSITION controls to separate the two traces.
- c. Set VERTICAL MODE to CHOP.
- d. CHECK—CH 1 and CH 2 displays are both displayed simultaneously.

## 7. Check VOLTS/DIV Variable Control Trace Shift

- a. Set:

VERTICAL MODE	CH 1
VOLTS/DIV (both)	2 mV
AC-GND-DC (both)	DC
A SEC/DIV	0.2 ms

- b. Center the trace on the center horizontal graticule line using the Channel 1 POSITION control.
- c. Rotate the CH 1 VOLTS/DIV Variable control counterclockwise through its full range.
- d. CHECK—That the trace does not shift more than 2.5 divisions.
- e. Return the CH 1 VOLTS/DIV Variable control to its CAL detent.
- f. Set the VERTICAL MODE switch to CH 2.
- g. Repeat parts b through e for CH 2.

## 8. Adjust Invert Balance (R264)

- a. Set the CH 2 VOLTS/DIV switch to 20 mV.
- b. Center the trace on the center horizontal graticule line using the Channel 2 POSITION control.
- c. Push in the INVERT button.
- d. ADJUST—Invert Bal (R264) to position the trace on the center horizontal graticule line.
- e. Return the INVERT button to Normal (button out).
- f. Repeat parts c through e until there is no trace shift when switching the INVERT button between Invert and Normal.

## 9. Adjust Trigger Balance (R154)

- a. Set the A & B INT switch to CH 2.
- b. Connect the digital voltmeter low lead to chassis ground (TP501) and the volts lead to pin 16 of U421; note the voltage reading for use in part d.
- c. Set the A & B INT switch to CH 1.
- d. ADJUST—Ch 1/Ch 2 Balance (R154) so that the voltage reading is the same as that obtained in part b.

**Adjustment Procedure—2215 Service**

e. Disconnect the test setup.

**10. Adjust Attenuator Compensation (C105, C104, C111, C110, C205, C204, C211, and C210)**

a. Set:

CH 1 VOLTS/DIV	20 mV
AC-GND-DC (both)	DC
A SEC/DIV	0.2 ms

b. Connect a 1-kHz, high-amplitude square wave via a 50-Ω termination, a probe-tip-to-bnc adapter, and a P6120 Probe to the CH 1 OR X input connector.

c. Set the generator output to produce a 5-division display and compensate the probe using the probe compensation adjustment (see the probe instruction manual).

d. Set the CH 1 VOLTS/DIV switch to 0.2 V.

e. Replace the probe and probe-tip-to-bnc adapter with a 50-Ω cable.

f. Adjust the generator output for a 5-division display.

**NOTE**

*Use Table 5-4 to identify the correct capacitor for each channel adjustment.*

g. ADJUST—The ÷10 LF Comp capacitor for best front corner.

**Table 5-4**  
**Attenuator Compensation Adjustments**

Adjustment	Channel 1	Channel 2
÷10 LF Comp	C105	C205
÷10 Input C	C104	C204
÷100 LF Comp	C111	C211
÷100 Input C	C110	C210

h. Replace the cable and 50-Ω termination with the P6120 Probe and probe-tip-to-bnc adapter.

i. Adjust the generator output for a 5-division display.

j. ADJUST—The ÷10 Input C capacitor for best flat top.

k. Repeat parts e through j until no further improvement is noted. Add the 50-Ω termination to the cable in part e.

l. Set the CH 1 VOLTS/DIV switch to 2 V.

m. Replace the probe and probe-tip-to-bnc adapter with the 50-Ω cable.

n. Adjust the generator output for a 5-division display.

o. ADJUST—The ÷100 LF Comp capacitor for best front corner.

p. Replace the 50-Ω cable with the probe and probe-tip-to-bnc adapter.

q. Adjust the generator output to produce a display as close as possible to 5 divisions.

r. ADJUST—The ÷100 Input C capacitor for best flat top.

s. Repeat parts m through r until no further improvement is noted.

t. Set the VERTICAL MODE switch to CH 2.

u. Repeat parts b through s for CH 2.

v. Disconnect the test setup.

**11. Adjust Vertical Output Amplifier Compensation (R357, C357, R367, R366, and C366)**

a. Set:

VOLTS/DIV (both)	20 mV
A SEC/DIV	0.05 μs

b. Connect a 1-MHz, positive-going fast-rise square-wave via a 50-Ω cable, a 10X attenuator, and a 50-Ω termination to the CH 2 OR Y input connector.



- c. Adjust the generator output for a 5-division display.
- d. Preset High Freq Comp (R357) fully counter-clockwise.
- e. ADJUST—High Freq Comp (C357) until ringing just disappears on the front corner.
- f. ADJUST—Low Freq Comp (R367) and Mid Freq Comp (R366 and C366) for best flat top beyond 20 ns from the corner.
- g. ADJUST—R357 and C357 for best corner on the first 20 ns of the displayed signal.
- h. Repeat parts f and g until no further improvement is noted.
- i. Set the CH 2 VOLTS/DIV switch to 0.1 V and repeat parts f and g for best compromise with the 20-mV VOLTS/DIV switch setting.
- j. Disconnect the test setup.

## 12. Adjust Channel Matching (C167) and Check Bandwidth

- a. Set:
 

VOLTS/DIV (both)	20 mV
A SEC/DIV	20 $\mu$ s
- b. Connect the leveled sine-wave generator output via a 50- $\Omega$  cable and a 50- $\Omega$  termination to the CH 2 OR Y input connector.
- c. Set the generator output for a 5-division, 50-kHz display.
- d. Increase the generator frequency until the display reduces to 3.5 divisions.
- e. Move the signal from the CH 2 OR Y input connector to the CH 1 OR X input connector. Set the VERTICAL MODE switch to CH 1.
- f. ADJUST—CH 1 & CH 2 HF Match (C167) for a vertical display amplitude of 3.5 divisions.

- g. Set both VOLTS/DIV switches to 2 mV.
- h. Connect the leveled sine-wave generator output via a 50- $\Omega$  cable and a 50- $\Omega$  termination to the CH 1 OR X input connector.
- i. Set the generator output amplitude for a 5-division, 50-kHz display.
- j. Change the generator output frequency to the value shown in Table 5-5 for the corresponding VOLTS/DIV switch setting.

**Table 5-5**  
Settings for Bandwidth Checks

VOLTS/DIV Switch Settings	Generator Output Frequency
2 mV to 10 mV	50 MHz
20 mV to 10 V	60 MHz

- k. CHECK—Display amplitude is 3.5 divisions or greater.
- l. Repeat parts i through k for all indicated CH 1 VOLTS/DIV switch settings, up to the output-voltage upper limit of the sine-wave generator being used.
- m. Move the generator output signal from the CH 1 OR X input connector to the CH 2 OR Y input connector. Set the VERTICAL MODE switch to CH 2.

- n. Repeat parts i through k for all indicated CH 2 VOLTS/DIV switch settings up to the output-voltage upper limit of the sine-wave generator being used.

- o. Disconnect the test setup.

## 13. Check Common-Mode Rejection Ratio

- a. Set both VOLTS/DIV switches to 20 mV.
- b. Connect a 10-MHz, leveled sine-wave signal via a 50- $\Omega$  cable, a 50- $\Omega$  termination, and a dual-input coupler to the CH 1 OR X and the CH 2 OR Y input connectors.
- c. Set the generator output amplitude to produce a 6-division display.



## Adjustment Procedure—2215 Service

d. Vertically center the display using the Channel 2 POSITION control. Then set VERTICAL MODE to CH 1 and vertically center the display using the Channel 1 POSITION control.

e. Set the VERTICAL MODE switches to BOTH and ADD; then push in the INVERT button.

f. CHECK—Display amplitude is 0.6 division or less.

g. If the check in part f meets the requirement, skip to part n. If it does not, continue with part h.

h. Set VERTICAL MODE to CH 1.

i. Change the generator frequency to 50 kHz and adjust the output to obtain a 6-division display.

j. Set VERTICAL MODE to BOTH.

k. Adjust the CH 2 VOLTS/DIV Variable control for minimum display amplitude (best CMRR).

l. Change the generator frequency to 10 MHz.

m. CHECK—Display amplitude is 0.6 division or less.

n. Disconnect the test setup.

### 14. Check POSITION Control Range

a. Set:

VERTICAL MODE	CH 1
VOLTS/DIV (both)	50 mV
AC-GND-DC (both)	AC

b. Connect a 0.5-V standard-amplitude signal via a 50- $\Omega$  cable to the CH 1 OR X input connector.

c. Adjust the CH 1 VOLTS/DIV Variable control for a 4.4-division display. Then set the CH 1 VOLTS/DIV switch to 10 mV.

d. CHECK—Rotating the Channel 1 POSITION control fully counterclockwise positions the top of the trace below the center horizontal graticule line.

e. CHECK—Rotating the Channel 1 POSITION control fully clockwise positions the bottom of the trace above the center horizontal graticule line.

f. Move the signal from the CH 1 OR X input connector to the CH 1 OR X input connector to the CH 2 OR Y input connector and set the VERTICAL MODE switch to CH 2.

g. Repeat parts c through e for Channel 2.

h. Disconnect the test setup.

### 15. Check Channel Isolation

a. Set:

CH 1 VOLTS/DIV	0.5 V
CH 2 VOLTS/DIV	10 mV
VERTICAL MODE	CH 1

b. Connect a 10-MHz leveled sine-wave signal via a 50- $\Omega$  cable and a 50- $\Omega$  termination to the CH 1 OR X input connector.

c. Adjust the generator output for an 8-division input connector.

d. Set the VERTICAL MODE switch to CH 2.

e. CHECK—Display amplitude is 4 divisions or less.

f. Move the input signal from the CH 1 OR X input connector to the CH 2 OR Y input connector

g. Set:

CH 1 VOLTS/DIV	10 mV
CH 2 VOLTS/DIV	0.5 V
VERTICAL MODE	CH 1

h. CHECK—Display amplitude is 4 divisions or less.

i. Disconnect the test setup.

# HORIZONTAL

## Equipment Required (see Table 4-1):

Calibration Generator (Item 1)	Two 50- $\Omega$ BNC Terminations (Item 5)
Leveled Sine-Wave Generator (Item 2)	Screwdriver (Item 14)
Time-Mark Generator (Item 3)	Low-Capacitance Alignment Tool (Item 15)
Two 50- $\Omega$ BNC Cables (Item 4)	

See **ADJUSTMENT LOCATIONS 1** and **ADJUSTMENT LOCATIONS 2**

at the back of this manual for test point and adjustment locations.

## INITIAL CONTROL SETTINGS

POWER	ON (button in)
<b>CRT</b>	
AUTO INTENSITY	As desired
AUTO FOCUS	Best focused display

### Vertical

Channel 1 POSITION	Midrange
VERTICAL MODE	CH 1
CH 1 VOLTS/DIV	0.5 V
CH 1 VOLTS/DIV	
Variable	CAL detent
INVERT	Normal (button out)
Channel 1 AC-GND-DC	DC
Channel 2 AC-GND-DC	GND

### Horizontal

POSITION	Midrange
HORIZONTAL MODE	A
A AND B SEC/DIV	0.1 ms
A AND B SEC/DIV	
Variable	CAL detent
X10 Magnifier	Off (knob in)
B DELAY TIME	
POSITION	1.00

### Trigger

VAR HOLDOFF	NORM
A TRIGGER MODE	AUTO
SLOPE (both)	
LEVEL (both)	Midrange
A & B INT	VERT MODE
A SOURCE	EXT
A EXT COUPLING	DC÷10

## PROCEDURE STEPS

### 1. Adjust Horizontal Amplifier Gain (R752, R682, and R733)

a. Connect 0.1-ms time markers from the time-mark generator via a 50- $\Omega$  cable and a 50- $\Omega$  termination to the CH 1 OR X input connector. Connect the generator Trigger output via a 50- $\Omega$  cable and a 50- $\Omega$  termination to the EXT INPUT connector.

b. ADJUST—Horiz Gain (R752) for 1 time marker per division.

c. Set the HORIZONTAL MODE switch to B.

d. ADJUST—B Gain (R682) for 1 time marker per division.

e. Set the HORIZONTAL MODE switch to A.

f. Set the X10 Magnifier on (knob out) and select 10- $\mu$ s time markers from the time-mark generator.

g. ADJUST—X10 Gain (R733) for 1 time marker per division.

### 2. Adjust Magnifier Registration (R758)

a. Select 0.5-ms time markers from the time-mark generator and set the X10 Magnifier off (knob in).

b. Position the middle time marker to the center vertical graticule line using the Horizontal POSITION control.

## Adjustment Procedure—2215 Service

- c. Set the X10 Magnifier on (knob out).
- d. ADJUST—Mag Registration (R758) to position the middle time marker on the center vertical graticule line.
- e. Set the X10 Magnifier off (knob in).
- f. CHECK—There is no discernable shift in the time marker when switching between X10 Magnifier on and X10 Magnifier off.
- g. Turn the X10 Magnifier on (knob out) and repeat parts b through e until no further improvement is noted.

### 3. Adjust Delay Dial Timing (R659 and R654)

- a. Set:

HORIZONTAL MODE	ALT
A SEC/DIV	0.1 ms
B SEC/DIV	1 $\mu$ s
X10 Magnifier	Off (knob in)

- b. Select 0.1-ms time markers from the time-mark generator and verify that the B DELAY TIME POSITION control is set to 1.00.
- c. ADJUST—Delay Dial Start Adj (R659) so that the 2nd A-sweep time marker is intensified and the B-sweep time marker starts at the beginning of the B sweep.
- d. Set the B DELAY TIME POSITION control to 9.00.
- e. ADJUST—Delay Dial Gain (R654) so that the 10th A-sweep time marker is intensified and the B-sweep time marker starts at the beginning of the B sweep.
- f. Set the B DELAY TIME POSITION control to 1.00 and repeat parts c through e until no further improvement is noted.

### 4. Adjust 5- $\mu$ s Timing (C676 and C626)

- a. Set:

HORIZONTAL MODE	B
A AND B SEC/DIV	5 $\mu$ s

- b. Select 5- $\mu$ s time markers from the time-mark generator.

- c. ADJUST—5  $\mu$ s Timing (C676) for 1 time marker per division across the graticule area.

- d. Set the HORIZONTAL MODE switch to A.

- e. ADJUST—5  $\mu$ s Timing (C626) for 1 time marker per division across the graticule area.

### 5. Adjust High-Speed Timing (C754, C774, C784, and C734)

- a. Set the A SEC/DIV switch to 0.05  $\mu$ s.

- b. Select 50-ns time markers from the time-mark generator.

- c. ADJUST—50 ns Linearity (C754) for equally spaced time markers at the start of the sweep.

- d. Set the X10 Magnifier on (knob out) and select 10-ns time markers from the time-mark generator.

#### NOTE

*In the next part, keep the adjustment screws for C774 and C784 as close to the same length as possible.*

- e. ADJUST—5 ns Timing (C774 and C784) alternately for one time marker every 2 divisions over the center 8 divisions of the magnified sweep.

- f. Adjust the Horizontal POSITION control so that the 5th time marker is aligned with the 2nd vertical graticule line.

- g. ADJUST—5 ns Linearity (C734) for one time marker every 2 divisions over the center 8 divisions of the magnified sweep. Adjust the Horizontal POSITION control to check the linearity to the 15th time marker.

- h. Repeat parts e through g until no further improvement is noted.

- i. Set the X10 Magnifier off (knob in) and recenter the trace using the Horizontal POSITION control.

- j. Repeat parts b through i until no further improvement is noted.

## 6. Check Timing Accuracy

a. Select 50-ns time markers from the time-mark generator.

b. Use the Channel 1 POSITION control to center the trace vertically. Adjust the A TRIGGER LEVEL control for a stable, triggered display.

c. Use the Horizontal POSITION control to align the first time marker that is 50 ns beyond the start of the sweep with the 2nd vertical graticule line.

### NOTE

*When making timing measurements, use as a reference the same point on each time marker.*

d. CHECK—Timing accuracy is within the limits shown in Table 5-6 for the applicable position of the X10 Magnifier. When making the check with the X10 Magnifier On, exclude any portion of the sweep past the 100th magnified division.

e. Set the HORIZONTAL MODE switch to B and adjust the B TRIGGER LEVEL control for a stable display.

f. Align the first time marker that is 50 ns beyond the start of the sweep with the 2nd vertical graticule line, using the Horizontal POSITION control.

g. CHECK—Timing accuracy is within the limits shown in Table 5-6 for the applicable position of the X10 Magnifier. When making the check with the X10 Magnifier On, exclude any portion of the sweep past the 100th magnified division.

h. Set the HORIZONTAL MODE switch to A.

i. Repeat parts b through h for the A and B SEC/DIV and time-mark generator setting combinations shown in Table 5-7 under the "Normal" column.

j. Set:

A and B SEC/DIV            0.05  $\mu$ s  
X10 Magnifier                On (knob out)

k. Select 10-ns time markers from the time-mark generator.

l. Repeat parts b through h for the A and B SEC/DIV and time-mark generator setting combinations shown in Table 5-7 under the "X10 Magnified" column.

**Table 5-6**

**A and B Timing Accuracy**

X10 Magnifier	Accuracy at 10th Vertical Graticule Line
Off (knob in)	3% (0.24 division)
On (knob out)	5% (0.40 division)

**Table 5-7**

**Settings for Timing Accuracy Checks**

A AND B SEC/DIV Switch Setting	Time-Mark Generator Output	
	Normal	X10 Magnified
0.05 $\mu$ s 0.1 $\mu$ s 0.2 $\mu$ s 0.5 $\mu$ s	50 ns 0.1 $\mu$ s 0.2 $\mu$ s 0.5 $\mu$ s	10 ns 10 ns 20 ns 50 ns
1 $\mu$ s 2 $\mu$ s 5 $\mu$ s	1 $\mu$ s 2 $\mu$ s 5 $\mu$ s	0.1 $\mu$ s 0.2 $\mu$ s 0.5 $\mu$ s
10 $\mu$ s 20 $\mu$ s 50 $\mu$ s	10 $\mu$ s 20 $\mu$ s 50 $\mu$ s	1 $\mu$ s 2 $\mu$ s 5 $\mu$ s
0.1 ms 0.2 ms 0.5 ms	0.1 ms 0.2 ms 0.5 ms	10 $\mu$ s 20 $\mu$ s 50 $\mu$ s
1 ms 2 ms 5 ms	1 ms 2 ms 5 ms	0.1 ms 0.2 ms 0.5 ms
10 ms 20 ms 50 ms	10 ms 20 ms 50 ms	1 ms 2 ms 5 ms
<b>A Sweep Only</b>		
0.1 s 0.2 s 0.5 s	0.1 s 0.2 s 0.5 s	10 ms 20 ms 50 ms

### 7. Check B DELAY TIME POSITION Control Range

a. Set:

Channel 1 AC-GND-DC	GND
HORIZONTAL MODE	ALT
A AND B SEC/DIV	0.2 ms

b. Align the start of the A sweep with the 1st vertical graticule line.

c. CHECK—Intensified portion of the trace starts within 0.5 division of the start of the sweep.

d. Rotate the B DELAY TIME POSITION control fully clockwise.

e. CHECK—Intensified zone is past the 11th vertical graticule line.

### 8. Check SEC/DIV Variable Range

a. Set:

CH 1 VOLTS/DIV	0.5 V
Channel 1 AC-GND-DC	DC
HORIZONTAL MODE	A
A SEC/DIV	0.2 ms
SEC/DIV Variable	Fully counterclockwise
X10 Magnifier	Off (knob in)

b. Select 0.5-ms time markers from the time-mark generator.

c. CHECK—Time markers are 1 division or less apart.

d. Return the SEC/DIV Variable control to the CAL detent.

### 9. Check B DELAY TIME POSITION Dial Accuracy

a. Set:

HORIZONTAL MODE	B
A SEC/DIV	0.2 $\mu$ s
B SEC/DIV	0.05 $\mu$ s
B TRIGGER LEVEL	CW-RUN AFTER DLY

b. Select 0.2- $\mu$ s time markers.

c. Set the B DELAY TIME POSITION control to 1.00. Adjust the Horizontal POSITION control so that the top of the first fully displayed time marker is aligned with the center vertical graticule line.

d. Without changing the Horizontal POSITION control setting, set the B DELAY TIME POSITION dial setting to 9.00. Slightly readjust the B DELAY TIME POSITION control to align the top of the time marker with the center vertical graticule line.

e. CHECK—The B DELAY TIME POSITION dial setting is between 8.87 and 9.14.

f. Set:

A SEC/DIV	0.5 ms
B SEC/DIV	50 $\mu$ s

g. Select 0.5- $\mu$ s time markers.

h. Repeat parts c through e.

### 10. Check Delay Jitter

a. Set the B SEC/DIV switch to 0.5  $\mu$ s.

b. Select 10- $\mu$ s time markers.

c. Slightly readjust the B DELAY TIME POSITION dial to position a time marker within the graticule area.

d. CHECK—Jitter on the leading edge of the time marker does not exceed 1 division. Disregard slow drift.

### 11. Check POSITION Control Range

a. Set:

A SEC/DIV	10 $\mu$ s
HORIZONTAL MODE	A

b. Select 50- $\mu$ s time markers.

c. Align the 3rd time marker with the center vertical graticule line.

d. Set the X10 Magnifier knob to On (knob out).

e. CHECK—Magnified time marker can be positioned to the left of the center vertical graticule line by rotating the Horizontal POSITION control fully counterclockwise.

f. CHECK—Start of the sweep can be positioned to the right of the center vertical graticule line by rotating the Horizontal POSITION control fully clockwise.

g. Disconnect the test setup.

## 12. Adjust X-Gain (R709)

a. Set:

CH 1 VOLTS/DIV	20 mV
A SEC/DIV	X-Y

b. Connect a 0.1-V standard-amplitude signal to the CH 1 OR X input connector using a 50- $\Omega$  cable.

c. ADJUST—X Gain (R709) for exactly 5 divisions of horizontal deflection.

d. Disconnect the test setup.

## 13. Check X-Bandwidth

a. Connect a 50-kHz leveled sine-wave signal via a 50- $\Omega$  cable and a 50- $\Omega$  termination to the CH 1 OR X input connector.

b. Set the generator to obtain a 5-division horizontal display.

c. Adjust the generator output frequency to 2 MHz.

d. CHECK—Display is at least 3.5 divisions in length.

e. Disconnect the test setup.

# TRIGGERING

## Equipment Required (see Table 4-1):

Leveled Sine-Wave Generator (Item 2)	BNC T-Connector (Item 8)
50-Ω BNC Cable (Item 4)	Probe-tip-to-BNC Adapter (Item 9)
50-Ω BNC Termination (Item 5)	Screwdriver (Item 14)
10X Attenuator (Item 7)	P6120 Probe (provided with instrument)

See **ADJUSTMENT LOCATIONS 1** at the back of this manual for test point and adjustment locations.

## INITIAL CONTROL SETTINGS

<b>POWER</b>	ON (button in)
<b>CRT</b>	
AUTO INTENSITY	As desired
AUTO FOCUS	Best focused display
<b>Vertical (both)</b>	
POSITION	Midrange
VERTICAL MODE	CH 1
VOLTS DIV	20 mV
VOLTS/DIV Variable	CAL detent
INVERT	Normal (button out)
AC-GND-DC	DC
<b>Horizontal</b>	
POSITION	Midrange
HORIZONTAL MODE	A
A AND B SEC/DIV	20 μs
A AND B SEC/DIV Variable	CAL detent
X10 Magnifier	Off (knob in)
<b>Trigger</b>	
VAR HOLDOFF	NORM
A TRIGGER MODE	AUTO
SLOPE (both)	↘
LEVEL (both)	Midrange
A & B INT	VERT MODE
A SOURCE	INT
A EXT COUPLING	DC

## PROCEDURE STEPS

### 1. Adjust Trigger Slope Balance (R482)

a. Connect the leveled sine-wave generator output via a 50-Ω cable and a 50-Ω termination to the CH 1 OR X input connector.

b. Adjust the generator output for a 50-kHz, 5-division display.

c. ADJUST—Slope Bal (R482) for a positive vertical shift of 0.15 division at the sweep start when changing the A TRIGGER SLOPE switch from ↘ to ↗.

### 2. Check/Adjust Auto Trigger Centering (R511 and R512) and TRIG'D LED Operation

a. Set:

A TRIGGER LEVEL	Fully clockwise
A TRIGGER SLOPE	↗

b. Adjust the generator output for a 1-division display.

c. ADJUST—(+) Auto (R511) so that the display just triggers on the positive peak of the signal.

d. Set:

A TRIGGER LEVEL	Fully counterclockwise
A TRIGGER SLOPE	↘

e. ADJUST—(−) Auto (R512) so that the display just triggers on the negative peak of the signal.

f. Set A TRIGGER MODE to NORM.

g. CHECK—TRIG'D LED is illuminated when a stable display is present and is off when the display is not triggered.

**3. Check Internal Triggering**

a. Set the CH 1 VOLTS/DIV switch to 2 mV.





b. Set the generator output to produce a 4-division, 2-MHz display.

c. Set the CH 1 VOLTS/DIV switch to 20 mV.

d. CHECK—Stable display can be obtained by adjusting the A TRIGGER LEVEL control for each switch combination given in Table 5-8.

**Table 5-8**

**Switch Combinations for A Triggering Checks**

TRIGGER MODE	TRIGGER SLOPE
NORM	
NORM	
AUTO	
AUTO	

e. Set the HORIZONTAL MODE switch to B.

f. CHECK—Stable display can be obtained by adjusting the B TRIGGER LEVEL control for both positive- and negative-going positions of the B TRIGGER SLOPE switch.

g. Set:

VERTICAL MODE            CH 2  
HORIZONTAL MODE        A

h. Move the generator output from the CH 1 OR X input connector to the CH 2 OR Y input connector. Set VERTICAL MODE to CH 2.

i. Repeat parts d through f.

j. Set:

HORIZONTAL MODE        A  
A SEC/DIV                    0.05  $\mu$ s

k. Set the generator to produce a 1.5-division, 60-MHz display.

l. Repeat part d.

m. Move the generator output from the CH 2 OR Y input connector to the CH 1 OR X input connector. Set VERTICAL MODE to CH 1.

n. Repeat part d.

o. Adjust the generator output and the A TRIGGER LEVEL control for a stable, 2-division display.

p. Repeat parts e and f.

q. Move the generator output from the CH 1 OR X input connector to the CH 2 OR Y input connector. Set VERTICAL MODE to CH 2.

r. Repeat part f.

s. Disconnect the test setup.

**4. Check External Triggering**

a. Set:

VOLTS/DIV (both)        10 mV  
A SEC/DIV                    10  $\mu$ s  
VERTICAL MODE            CH 1

b. Connect the test setup as shown in Figure 4-1.

c. Set the leveled sine-wave generator to produce a 5-division, 50-kHz display.

d. Set:

VERTICAL MODE            CH 2  
A SEC/DIV                    0.2  $\mu$ s  
A SOURCE                    EXT



**Adjustment Procedure—2215 Service**

e. Move the signal from the CH 1 OR X input connector to the EXT INPUT connector.

f. Set the generator to 2 MHz.

g. CHECK—Stable display can be obtained by adjusting the A TRIGGER LEVEL control for each switch combination given in Table 5-8.

h. Remove the 10X attenuator from the test setup and set the A EXT COUPLING switch to DC÷10.

i. Repeat part g.

j. Set:

VOLTS/DIV (both)	50 mV
VERTICAL MODE	CH 1
A SEC/DIV	20 $\mu$ S
A SOURCE	INT

k. Reconnect the test setup as shown in Figure 4-1.

l. Set the leveled sine-wave generator to produce a 5-division, 50-kHz display.

m. Set:

VERTICAL MODE	CH 2
A SEC/DIV	0.05 $\mu$ S
X10 MAGNIFIER	On (knob out)
A SOURCE	EXT

n. Repeat part e.

o. Set the generator to 60 MHz.

p. Repeat parts g and h.

q. Repeat part g.

r. Disconnect the test setup.

# EXTERNAL Z-AXIS AND PROBE ADJUST

## Equipment Required (see Table 4-1):

Leveled Sine-Wave Generator (Item 2)  
Two 50- $\Omega$  BNC Cables (Item 4)

BNC T-Connector (Item 8)  
P6120 Probe (provided with instrument)

## INITIAL CONTROL SETTINGS

POWER	ON
<b>CRT</b>	
AUTO INTENSITY	As desired
AUTO FOCUS	Best defined display
<b>Vertical</b>	
Channel 1 POSITION	Midrange
VERTICAL MODE	CH 1
CH 1 VOLTS/DIV	2 V
CH 1 VOLTS/DIV	
Variable	CAL detent
Channel 1 AC-GND-DC	DC
<b>Horizontal</b>	
POSITION	Midrange
HORIZONTAL MODE	A
A SEC/DIV	20 $\mu$ s
A AND B SEC/DIV	
Variable	CAL detent
<b>Trigger</b>	
VAR HOLDOFF	NORM
A TRIGGER MODE	AUTO
A TRIGGER SLOPE	$\swarrow$
A TRIGGER LEVEL	Midrange
A & B INT	VERT MODE
A SOURCE	INT

## PROCEDURE STEPS

### 1. Check EXT Z-AXIS Operation

a. Connect the leveled sine-wave generator output via a T-connector and two 50- $\Omega$  cables to the EXT Z-AXIS INPUT connector on the rear panel and to the CH 1 OR X input connector.

b. Adjust the generator controls to produce a 5-volt, 50 kHz display.

c. CHECK—For noticeable intensity modulation. The positive part of the sine wave should be of lower intensity than the negative part.

d. Disconnect the test setup.

### 2. Check PROBE ADJUST Operation

a. Set:

CH 1 VOLTS/DIV	10 mV
A SEC/DIV	0.5 ms

b. Connect the P6120 Probe to the CH 1 OR X input connector and insert the probe tip into the PROBE ADJUST jack on the instrument front panel. If necessary, adjust the probe compensation for a flat-topped square-wave display.

c. CHECK—Display is 5 divisions  $\pm$ 1 division (4 to 6 divisions).

d. Disconnect the test setup.

# MAINTENANCE

This section of the manual contains information for conducting preventive maintenance, troubleshooting, and corrective maintenance on the 2215 Oscilloscope.

## STATIC-SENSITIVE COMPONENTS

The following precautions are applicable when performing any maintenance involving internal access to the instrument.



*Static discharge can damage any semiconductor component in this instrument.*

This instrument contains electrical components that are susceptible to damage from static discharge. Table 6-1 lists the relative susceptibility of various classes of semiconductors. Static voltages of 1 kV to 30 kV are common in unprotected environments.

When performing maintenance observe the following precautions to avoid component damage:

1. Minimize handling of static-sensitive components.
2. Transport and store static-sensitive components or assemblies in their original containers or on a metal rail. Label any package that contains static-sensitive components or assemblies.
3. Discharge the static voltage from your body by wearing a grounded antistatic wrist strap while handling these components. Servicing static-sensitive components or assemblies should be performed only at a static-free work station by qualified service personnel.
4. Nothing capable of generating or holding a static charge should be allowed on the work station surface.

5. Keep the component leads shorted together whenever possible.

6. Pick up components by their bodies, never by their leads.

Table 6-1

Relative Susceptibility to  
Static-Discharge Damage

Semiconductor Classes	Relative Susceptibility Levels <sup>a</sup>
MOS or CMOS microcircuits or discretes, or linear microcircuits with MOS inputs (Most Sensitive)	1
ECL	2
Schottky signal diodes	3
Schottky TTL	4
High-frequency bipolar transistors	5
JFET	6
Linear microcircuits	7
Low-power Schottky TTL	8
TTL (Least Sensitive)	9

<sup>a</sup>Voltage equivalent for levels (voltage discharged from a 100-pF capacitor through a resistance of 100 Ω):

1 = 100 to 500 V	4 = 500 V	7 = 400 to 1000 V (est)
2 = 200 to 500 V	5 = 400 to 600 V	8 = 900 V
3 = 250 V	6 = 600 to 800 V	9 = 1200 V

7. Do not slide the components over any surface.
8. Avoid handling components in areas that have a floor or work-surface covering capable of generating a static charge.
9. Use a soldering iron that is connected to earth ground.
10. Use only approved antistatic, vacuum-type desoldering tools for component removal.

## PREVENTIVE MAINTENANCE

### INTRODUCTION

Preventive maintenance consists of cleaning, visual inspection, lubrication, and checking instrument performance. When accomplished regularly, it may prevent instrument malfunction and enhance instrument reliability. The severity of the environment in which the instrument is used determines the required frequency of maintenance. An appropriate time to accomplish preventive maintenance is just before instrument adjustment.

### GENERAL CARE

The cabinet minimizes accumulation of dust inside the instrument and should normally be in place when operating the 2215. The optional front-panel cover provides both dust and damage protection for the front panel and crt face, and it should be in place whenever the instrument is stored or is being transported.

### INSPECTION AND CLEANING

The instrument should be visually inspected and cleaned as often as operating conditions require. Accumulation of dirt in the instrument can cause overheating and component breakdown. Dirt on components acts as an insulating blanket, preventing efficient heat dissipation. It also provides an electrical conduction path that could result in instrument failure, especially under high-humidity conditions.

#### CAUTION

*Avoid the use of chemical cleaning agents which might damage the plastics used in this instrument. Use a nonresidue-type cleaner, preferably isopropyl alcohol, denatured ethyl alcohol, or a solution of 1% mild detergent with 99% water. Before using any other type of cleaner, consult your Tektronix Service Center or representative.*

### Exterior

**INSPECTION.** Inspect the external portions of the instrument for damage, wear, and missing parts; use Table 6-2 as a guide. Instruments that appear to have been dropped or otherwise abused should be checked thoroughly to verify correct operation and performance. Deficiencies found that could cause personal injury or could lead to further damage to the instrument should be repaired immediately.

#### CAUTION

*To prevent getting moisture inside the instrument during external cleaning, use only enough liquid to dampen the cloth or applicator.*

**CLEANING.** Loose dust on the outside of the instrument can be removed with a soft cloth or small soft-bristle brush. The brush is particularly useful for dislodging dirt on and around the controls and connectors. Dirt that remains can be removed with a soft cloth dampened in a mild detergent-and-water solution. Do not use abrasive cleaners. Clean the light filter and the crt face with a soft lint-free cloth dampened with either denatured alcohol or a mild detergent-and-water solution.

### Interior

To gain access to internal portions of the instrument for inspection and cleaning, refer to the "Removal and Replacement Instructions" in the "Corrective Maintenance" part of this section.

**INSPECTION.** Inspect the internal portions of the instrument for damage and wear, using Table 6-3 as a guide. Deficiencies found should be repaired immediately. The corrective procedure for most visible defects is obvious; however, particular care must be taken if heat-damaged components are found. Overheating usually indicates other trouble in the instrument; therefore, it is important that the cause of overheating be corrected to prevent recurrence of the damage.

**Table 6-2**  
**External Inspection Checklist**

Item	Inspect For	Repair Action
Cabinet and Front Panel	Cracks, scratches, deformations, and damaged hardware or gaskets.	Touch up paint scratches and replace defective parts.
Front-panel Controls	Missing, damaged, or loose knobs, buttons, and controls.	Repair or replace missing or defective items.
Connectors	Broken shells, cracked insulation, and deformed contacts. Dirt in connectors.	Replace defective parts. Clean or wash out dirt.
Carrying Handle	Correct operation.	Replace defective parts.
Accessories	Missing items or parts of items, bent pins, broken or frayed cables, and damaged connectors.	Replace damaged or missing items, frayed cables, and defective parts.

**Table 6-3**  
**Internal Inspection Checklist**

Item	Inspect For	Repair Action
Circuit Boards	Loose, broken, or corroded solder connections. Burned circuit boards. Burned, broken, or cracked circuit-run plating.	Clean solder corrosion with an eraser and flush with isopropyl alcohol. Resolder defective connections. Determine cause of burned items and repair. Repair defective circuit runs.
Resistors	Burned, cracked, broken, or blistered.	Replace defective resistors. Check for cause of burned component and repair as necessary.
Solder Connections	Cold solder or rosin joints.	Resolder joint and clean with isopropyl alcohol.
Capacitors	Damaged or leaking cases. Corroded solder on leads or terminals.	Replace defective capacitors. Clean solder connections and flush with isopropyl alcohol.
Wiring and Cables	Loose plugs or connectors. Burned, broken, or frayed wiring.	Firmly seat connectors. Repair or replace defective wires or cables.
Chassis	Dents, deformations, and damaged hardware.	Straighten, repair, or replace defective hardware.

If any electrical component is replaced, conduct a Performance Check of the affected circuit and of other closely related circuits (see Section 4). If repair or replacement work is done on any of the power supplies, conduct a complete Performance Check and, if so indicated, an instrument readjustment (see Section 5).



*To prevent damage from electrical arcing, ensure that circuit boards and components are dry before applying power to the instrument.*

**CLEANING.** To clean the interior, blow off dust with dry, low-pressure air (approximately 9 psi). Remove any remaining dust with a soft brush or a cloth dampened with a solution of mild detergent and water. A cotton-tipped applicator is useful for cleaning in narrow spaces and on circuit boards.

If these methods do not remove all the dust or dirt, the instrument may be spray washed using a solution of 5% mild detergent and 95% water as follows:

1. Gain access to the parts to be cleaned (see "Removal and Replacement Instructions").

2. Spray wash dirty parts with the detergent-and-water solution; then use clean water to thoroughly rinse them.

3. Dry all parts with low-pressure air.

**SWITCH CONTACTS.** The Vertical and Horizontal attenuators in this instrument are circuit-board mounted rotary switches. When cleaning them, care must be exercised to preserve their high-frequency characteristics. Switch maintenance is seldom necessary, but if it is required, use the following cleaning method and observe the stated precaution.



*Use only hot deionized or distilled water, 55°C (131°F), to clean a rotary switch in this instrument. Tap water contains impurities which are left as residuals after evaporation.*

1. Spray hot water into the slots at the top of each switch housing while rotating the switch control knob. Spray only for approximately five seconds, using an atomizing spray device.

2. Dry both the switch and the circuit board on which it is mounted, using dry low-pressure air.

3. Bake the switch and the circuit board at 75°C (167°F) for 15 minutes to eliminate all moisture.

4. Spray a very small amount (only about a 1/2-second squirt) of a recommended lubricant, such as No Noise, into the slots at the top of the switch housing.

5. Rotate the switch control knob about 180° and again spray a very small amount of lubricant into each slot.

## LUBRICATION

Most of the potentiometers used in this instrument are permanently sealed and generally do not require periodic lubrication. All switches, both rotary- and lever-type, are installed with proper lubrication applied where necessary and will rarely require any additional lubrication. Therefore, a regular periodic lubrication program for the instrument is not recommended.

## SEMICONDUCTOR CHECKS

Periodic checks of the transistors and other semiconductors in the oscilloscope are not recommended. The best check of semiconductor performance is actual operation in the instrument.

## PERIODIC READJUSTMENT

To ensure accurate measurements, check the performance of this instrument after every 2000 hours of operation, or if used infrequently, once each year. In addition, replacement of components may necessitate readjustment of the affected circuits.

Complete Performance Check and Adjustment instructions are given in Sections 4 and 5. The Performance Check Procedure can also be helpful in localizing certain trouble in the instrument. In some cases, minor problems may be revealed or corrected by readjustment. If only a partial adjustment is performed, see the interaction chart, Table 5-1, for possible adjustment interactions with other circuits.

# TROUBLESHOOTING

## INTRODUCTION

Preventive maintenance performed on a regular basis should reveal most potential problems before an instrument malfunctions. However, should troubleshooting be required, the following information is provided to facilitate location of a fault. In addition, the material presented in the “Theory of Operation” and the “Diagrams” sections of this manual may be helpful while troubleshooting.

## TROUBLESHOOTING AIDS

### Schematic Diagrams

Complete schematic diagrams are located on tabbed foldout pages in the “Diagrams” section. The portions of circuitry that are mounted on each circuit board are enclosed within heavy black lines. Also within the black lines, near either the top or the bottom edge, are the assembly number and name of the circuit board.

Component numbers and electrical values of components in this instrument are shown on the schematic diagrams. Refer to the first page of the “Diagrams” section for definitions of the reference designators and symbols used to identify components. Important voltages and waveform reference numbers (enclosed in hexagonal-shaped boxes) are also shown on each diagram. Waveform illustrations are located adjacent to their respective schematic diagram, and the physical location of each waveform test point is shown on the appropriate circuit board illustration.

### Circuit Board Illustrations

Circuit board illustrations (showing the physical location of each component) are provided for use in conjunction with each schematic diagram. Each board illustration can be found on the back side of a foldout page, preceding the schematic diagram(s) to which it relates. If more than one schematic diagram is associated with a particular circuit board, the board illustration is located on a left-hand page preceding the diagram with which the board is first associated.

Also provided in the “Diagrams” section is an illustration of the bottom side of the Main circuit board. This drawing facilitates troubleshooting by showing the connection pads and the location of components that are mounted on the top side of the board. Probing of Main board component signals that are inaccessible from the

top side can be achieved without the necessity of disassembling portions of the instrument.

Waveform test-point locations are also identified on the circuit board illustration by hexagonal-outlined numbers that correspond to the waveform numbers appearing on both the schematic diagram and the waveform illustration.

### Circuit Board Locations

An illustration depicting the location of a circuit board within the instrument is shown on the foldout page adjacent to the circuit board illustration.

### Circuit Board Interconnection Diagram

A circuit board interconnection diagram is also provided in the “Diagrams” section to aid in tracing a signal path or power source between boards. The entire oscilloscope is illustrated, with plug and jack numbers shown along with associated pin numbers. The off-board components are also shown, and the schematic diagram numbers on which these components can be found are identified.

### Power Distribution Diagram

A Power Distribution diagram is provided to aid in troubleshooting power-supply problems. This diagram shows service jumpers used to remove power from the various circuit boards. Excessive loading on a power supply by a circuit board can be isolated to the faulty board by disconnecting appropriate service jumpers.

### Grid Coordinate System

Each schematic diagram and circuit board illustration has a grid border along its left and top edges. A table located adjacent to each schematic diagram lists the grid coordinates of each component shown on that schematic. To aid in physically locating a component on the respective circuit board, this table also lists the circuit-board grid coordinate of each component.

Adjacent to each circuit board illustration is an alphanumeric listing of every component mounted on that board. A second column in this listing identifies the schematic diagram in which each component can be found. These component-locator tables are especially useful when more than one schematic diagram is associated with a particular circuit board.

## Troubleshooting Charts

The troubleshooting charts contained in the “Diagrams” section are to be used as an aid in locating malfunctioning circuitry. To use the charts, begin with the Troubleshooting Guide. This chart will help identify a particular problem area for further troubleshooting.

Note that some troubleshooting-procedure boxes on each chart contain numbers along their lower edges. These numbers identify the applicable schematic diagram(s) to be used when performing the action specified in the box.

Both General and Specific notes may be called out in the troubleshooting-chart boxes. These notes are located on the inner panels of the foldout pages. Specific Notes contain procedures or additional information to be used in performing the particular troubleshooting step called for in that box. General Notes contain information that pertains to the overall troubleshooting procedure.

Some malfunctions, especially those involving multiple simultaneous failures, may require more elaborate troubleshooting approaches with references to circuit descriptions in the “Theory of Operation” section of this manual.

## Component Color Coding

Information regarding color codes and markings of resistors and capacitors is located in the color-coding illustration (Figure 9-1) at the beginning of the “Diagrams” section.

**RESISTOR COLOR CODE.** Resistors used in this instrument are carbon-film; composition, or precision metal-film types. They are color coded with the EIA color code; however, some metal-film resistors may have the value printed on the body. The color code is interpreted by starting with the stripe that is nearest to one end of the resistor. Composition resistors have four stripes; these represent two significant figures, a multiplier, and a tolerance value. Metal-film resistors have five stripes which represent three significant figures, a multiplier, and a tolerance value.

**CAPACITOR MARKINGS.** Capacitance values of common disc capacitors and small electrolytics are marked on the side of the capacitor body. White ceramic capacitors are color coded in picofarads, using a modified EIA code.

Dipped tantalum capacitors are color coded in microfarads. The color dot indicates both the positive lead and the voltage rating. Since these capacitors are easily destroyed by reversed or excessive voltage, be careful to observe the polarity and voltage rating.

**DIODE COLOR CODE.** The cathode end of each glass-encased diode is indicated by either a stripe, a series of stripes, or a dot. For most silicon or germanium diodes marked with a series of stripes, the color combination of the stripes identifies three digits of the Tektronix Part Number, using the resistor color-code system (e.g., a diode having either a pink or a blue stripe at the cathode end, then a brown-gray-green stripe combination, indicates Tektronix Part Number 152-0185-00). The cathode and anode ends of a metal-encased diode can be identified by the diode symbol marked on its body.

## Semiconductor Lead Configurations

Figure 9-2 in the “Diagrams” section shows the lead configurations for semiconductor devices used in the instrument. These lead configurations and case styles are typical of those available at completion of the design of the instrument. Vendor changes and performance improvement changes may result in changes of case styles or lead configurations. If the device in question does not appear to match the configuration in Figure 9-2, examine the associated circuitry or consult a semiconductor manufacturer’s data sheet.

## Multipin Connectors

Multipin connector orientation is indicated by two triangles: one on the holder and one on the circuit board. Slot numbers are usually molded into the holder. When a connection is made to circuit-board pins, ensure that the triangle on the holder and the triangle on the circuit board are aligned with each other (see Figure 6-1).

# TROUBLESHOOTING EQUIPMENT

The equipment listed in Table 4-1, or equivalent equipment, may be useful when troubleshooting this instrument.

# TROUBLESHOOTING TECHNIQUES

The following procedure is arranged in an order that enables checking simple trouble possibilities before requiring more extensive troubleshooting. The first four checks ensure proper control settings, connections, operation, and adjustment. If the trouble is not located by these checks, the remaining steps will aid in locating the defective component. When the defective component is



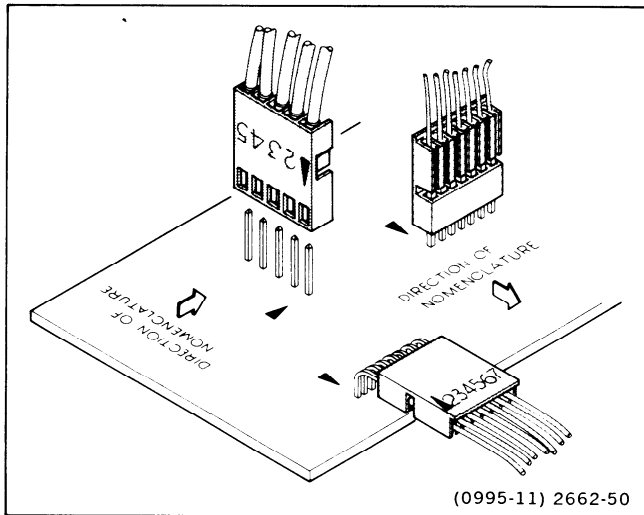

Figure 6-1. Multipin connector orientation.

located, replace it, using the appropriate replacement procedure given under "Corrective Maintenance" in this section.

### CAUTION

*Before using any test equipment to make measurements on static-sensitive, current-sensitive, or voltage-sensitive components or assemblies, ensure that any voltage or current supplied by the test equipment does not exceed the limits of the component to be tested.*

## 1. Check Control Settings

Incorrect control settings can give a false indication of instrument malfunction. If there is any question about the correct function or operation of any control, refer to either the "Operating Instructions" (Section 2) in this manual or to the instrument Operators Manual.

## 2. Check Associated Equipment

Before proceeding, ensure that any equipment used with this instrument is operating correctly. Verify that input signals are properly connected and that the interconnecting cables are not defective. Check the power-input-source voltages.

### WARNING

*To avoid electric shock, disconnect the instrument from the power-input source before performing visual inspection.*

## 3. Visual Check

Perform a visual inspection. This check may reveal broken connections or wires, damaged components, semi-conductors not firmly mounted, damaged circuit boards, or other clues.

### WARNING

*Dangerous potentials exist at several points throughout this instrument. If it is operated with the cabinet removed, do not touch exposed connections or components.*

## 4. Check Instrument Performance and Adjustment

Check the performance of either those circuits where trouble appears to exist or the entire instrument. The apparent trouble may only be the result of misadjustment. Complete performance check and adjustment instructions are given in Sections 4 and 5 of this manual.

## 5. Isolate Trouble to a Circuit

To isolate problems to a particular area, use the trouble symptom to help identify the circuit in which the trouble is located. Refer to the troubleshooting charts in the "Diagrams" section as an aid in locating a faulty circuit.

## 6. Check Power Supplies

### WARNING

*It is recommended for safety that an isolation transformer be connected between the ac-power source and the autotransformer whenever troubleshooting is done in the Preregulator and the Inverter Power Supply sections. Most autotransformers are NOT isolation transformers.*

Check the power supplies whenever trouble symptoms appear in more than one circuit. The correct output voltage and ripple for each supply should be measured between the supply test point and chassis ground (see Diagram 9 and its associated circuit board illustration). When checking power-supply circuitry utilizing common as the reference, use either a DMM or an oscilloscope and observe the preceding WARNING. If power supply voltages and ripple are within their listed ranges, the supply can be assumed to be operating correctly. If any are outside their ranges, the supply may be either misadjusted or operating incorrectly. A defective component elsewhere in the instrument can create the appearance of a power-supply problem and may also affect the operation of other circuits.

## 7. Check Circuit Board Interconnections

After the trouble has been isolated to a particular circuit, again check for loose or broken connections and heat-damaged components.

## 8. Check Voltages and Waveforms

Often the defective component can be located by checking the appropriate voltage or waveform in the circuit. Typical voltages are listed on the schematic diagrams. Waveforms are shown adjacent to the schematics, and waveform test points are indicated on both the schematics and circuit board illustrations by hexagonal-outlined numbers.

### NOTE

*Voltages and waveforms given on the schematic diagrams are not absolute and may vary slightly between instruments. To establish operating conditions similar to those used to obtain these readings, see the "Voltage and Waveform Setup" conditions in the "Diagrams" section for the preliminary equipment setup. Note the recommended test equipment, initial front-panel control settings, and cable-connection instructions. The control-setting changes (from initial setup) required to obtain the given waveforms and voltages are located on the waveform-diagram page.*

### WARNING

*To avoid electric shock, always disconnect the instrument from the power input source before removing or replacing components.*

## 9. Check Individual Components

The following procedures describe methods of checking individual components. Two-lead components that are soldered in place are most accurately checked by first disconnecting one end from the circuit board. This isolates the measurement from the effects of surrounding circuitry. See Figure 9-1 for value identification or Figure 9-2 for typical semiconductor lead configuration.

### CAUTION

*When checking semiconductors, observe the static-sensitivity precautions located at the beginning of this section.*

**TRANSISTORS.** A good check of transistor operation is actual performance under operating conditions. A transistor can most effectively be checked by substituting a

known good component. However, be sure that circuit conditions are not such that a replacement transistor might also be damaged. If substitute transistors are not available, use a dynamic tester. Static-type testers are not recommended, since they do not check operation under simulated operating conditions.

When troubleshooting transistors in the circuit with a voltmeter, measure both the emitter-to-base and emitter-to-collector voltages to determine whether they are consistent with normal circuit voltages. Voltages across a transistor may vary with the type of device and its circuit function.

Some of these voltages are predictable. The emitter-to-base voltage for a conducting silicon transistor will normally range from 0.6 to 0.8 V, and the emitter-to-base voltage for a conducting germanium transistor ranges from 0.2 to 0.4 V. The emitter-to-collector voltage for a saturated transistor is about 0.2 V. Because these values are small, the best way to check them is by connecting a sensitive voltmeter across the junction rather than comparing two voltages taken with respect to ground. If the former method is used, both leads of the voltmeter must be isolated from ground.

If values less than these are obtained, either the device is shorted or no current is flowing in the external circuit. If values exceed the emitter-to-base values given, either the junction is reverse biased or the device is defective. Voltages exceeding those given for typical emitter-to-collector values could indicate either a nonsaturated device operating normally or a defective (open-circuited) transistor. If the device is conducting, voltage will be developed across the resistors in series with it; if it is open, no voltage will be developed across the resistors in series with it, unless current is being supplied by a parallel path.

### CAUTION

*When checking emitter-to-base junctions, do not use an ohmmeter range that has a high internal current. High current can damage the transistor. Reverse biasing the emitter-to-base junction with a high current may degrade the transistor's current-transfer ratio (Beta).*

A transistor emitter-to-base junction also can be checked for an open or shorted condition by measuring the resistance between terminals with an ohmmeter set to a range having a low internal source current, such as the R X 1 k $\Omega$  range. The junction resistance should be very high in one direction and very low when the meter leads are reversed.

When troubleshooting a field-effect transistor, the voltage across its elements can be checked in the same manner as previously described for other transistors. However, remember that in the normal depletion mode of operation, the gate-to-source junction is reverse biased; in the enhanced mode, the junction is forward biased.

**INTEGRATED CIRCUITS.** An integrated circuit (IC) can be checked with a voltmeter, test oscilloscope, or by direct substitution. A good understanding of circuit operation is essential to troubleshooting a circuit having an IC. Use care when checking voltages and waveforms around the IC so that adjacent leads are not shorted together. The grabber tip or an IC test clip provides a convenient means of clipping a test probe to an IC.

**CAUTION**

*When checking a diode, do not use an ohmmeter range that has a high internal current. High current can damage the diode. Checks on diodes can be performed in much the same manner as on transistor emitter-to-base junctions. Do not check tunnel diodes or back diodes with an ohmmeter; use a dynamic tester, such as the TEKTRONIX 576 Curve Tracer.*

**DIODES.** A diode can be checked for either an open or a shorted condition by measuring the resistance between terminals with an ohmmeter set to a range having a low internal source current, such as the R X 1 k $\Omega$  range. The diode resistance should be very high in one direction and very low when the meter leads are reversed.

Silicon diodes should have 0.6 to 0.8 V across their junctions when conducting. Higher readings indicate that they are either reverse biased or defective, depending on polarity.

**RESISTORS.** Check resistors with an ohmmeter. Refer to the "Replaceable Electrical Parts" list for the tolerances of resistors used in this instrument. A resistor normally does not require replacement unless its measured value varies widely from its specified value and tolerance.

**INDUCTORS.** Check for open inductors by checking continuity with an ohmmeter. Shorted or partially shorted inductors can usually be found by checking the waveform response when high-frequency signals are passed through the circuit.

**CAPACITORS.** A leaky or shorted capacitor can best be detected by checking resistance with an ohmmeter set to one of the highest ranges. Do not exceed the voltage rating of the capacitor. The resistance reading should be high after the capacitor is charged to the output voltage of the ohmmeter. An open capacitor can be detected with a capacitance meter or by checking whether the capacitor passes ac signals.

## 10. Repair and Adjust the Circuit

If any defective parts are located, follow the replacement procedures given under "Corrective Maintenance" in this section. After any electrical component has been replaced, the performance for that particular circuit should be checked, as well as the performance of other closely related circuits. Since the power supplies affect all circuits, performance of the entire instrument should be checked if work has been done in any of the power supplies or if the power transformer has been replaced. Readjustment of the affected circuitry may be necessary. Refer to the "Performance Check Procedure" and "Adjustment Procedure" (Sections 4 and 5) and to Table 5-1 (Adjustment Interactions).

# CORRECTIVE MAINTENANCE

## INTRODUCTION

Corrective maintenance consists of component replacement and instrument repair. This part of the manual describes special techniques and procedures required to replace components in this instrument. If it is necessary to ship your instrument to a Tektronix Service Center for repair or service, refer to the "Repackaging for Shipment" instructions at the end of this section.

## MAINTENANCE PRECAUTIONS

To reduce the possibility of personal injury or instrument damage, observe the following precautions.

1. Disconnect the instrument from the ac power input source before removing or installing components.
2. Use care not to interconnect instrument grounds which may be at different potentials (cross grounding).
3. When soldering on circuit boards or small insulated wires, use only a 15-watt, pencil-type soldering iron.

## OBTAINING REPLACEMENT PARTS

Most electrical and mechanical parts can be obtained through your local Tektronix Field Office or representative. However, many of the standard electronic components can usually be obtained from a local commercial source. Before purchasing or ordering a part from a source other than Tektronix, Inc., please check the "Replaceable Electrical Parts" list (Section 8) for the proper value, rating, tolerance, and description.

### NOTE

*Physical size and shape of a component may affect instrument performance, particularly at high frequencies. Always use direct-replacement components, unless it is known that a substitute will not degrade instrument performance.*

### Special Parts

In addition to the standard electronic components, some special parts are used in this instrument. These

parts are manufactured or selected by Tektronix, Inc. to meet specific performance requirements, or are manufactured for Tektronix, Inc. in accordance with our specifications. The various manufacturers can be identified by referring to the "Cross Index—Mfr Code Number to Manufacturer" at the beginning of the "Replaceable Electrical Parts" list. Most of the mechanical parts used in this instrument were manufactured by Tektronix, Inc. Order all special parts directly from your local Tektronix Field Office or representative.

### Ordering Parts

When ordering replacement parts from Tektronix, Inc., be sure to include all of the following information:

1. Instrument type (include modification or option numbers).
2. Instrument serial number.
3. A description of the part (if electrical, include its component number).
4. Tektronix part number.

## MAINTENANCE AIDS

The maintenance aids listed in Table 6-4 include items required for performing most of the maintenance procedures on this instrument. Equivalent products may be substituted for the examples given, provided their characteristics are similar.

## INTERCONNECTIONS

Pin connectors are used to connect wires to the interconnecting pins. They are grouped together and mounted in a plastic holder and should be removed, reinstalled, or replaced as a unit. If an individual wire or connector in the assembly is faulty, the entire cable assembly should be replaced. To provide correct orientation of this multipin connector when it is reconnected to its mating pins, an arrow is stamped on the circuit board, and a matching arrow is molded into the plastic housing of the multipin connector. Be sure these arrows are aligned with each other when the multipin connector is reinstalled.

**Table 6-4**  
**Maintenance Aids**

Description	Specifications	Usage	Example
1. Soldering Iron	15 to 25 W.	General soldering and unsoldering.	Antex Precision Model C.
2. Torx Screwdrivers	Torx tips #T7, #T8, #T9, #T15 and #T20.	Assembly and disassembly.	Tektronix Part Numbers #T7) 003-1293-00 #T8) 003-0964-00 #T9) 003-0965-00 #T15) 003-0966-00 #T20) 003-0866-00
3. Nutdrivers	1/4 inch, 9/32 inch, 5/16 inch, 1/2 inch, and 9/16 inch.	Assembly and disassembly.	Xcelite #8, #9, #10, #16, and #18.
4. Open-end Wrenches	1/4 inch, 7/16 inch, 1/2 inch, 9/16 inch, and 5/8 inch.	Assembly and disassembly.	
5. Allen Wrenches	0.050 inch and 1/16 inch.,	Assembly and disassembly.	
6. Long-nose Pliers		Component removal and replacement.	
7. Diagonal Cutters		Component removal and replacement.	
8. Vacuum Solder Extractor	No static charge retention.	Unsoldering components.	Pace Model PC-10.
9. Lubricant	No-Noise.	Switch lubrication.	Tektronix Part Number 006-0442-02.
10. Pin-replacement Kit		Replace circuit board connector pins.	Tektronix Part Number 040-0542-00.

## TRANSISTORS AND INTEGRATED CIRCUITS

Transistors and integrated circuits should not be replaced unless they are actually defective. If unsoldered from the circuit board during routine maintenance, return them to their original board locations. Unnecessary replacement or transposing of semiconductor devices may affect the adjustment of the instrument. When a semiconductor is replaced, check the performance of any instrument circuit that may be affected.

Any replacement component should be of the original type or a direct replacement. Bend transistor leads to fit their circuit board holes and cut the leads to the same length as the original component. See Figure 9-2 for typical lead-configuration illustrations.

To remove a soldered dual-in-line packaged (DIP) IC, do not heat adjacent conductors consecutively. Apply heat to pins at alternate sides and ends of the IC as solder is removed. Allow a moment for the circuit board to cool before proceeding to the next pin.

The heat-sink-mounted power supply transistors are insulated from the heat sink. In addition, a heat-sink compound is used to increase heat transfer capabilities. Reinstall the insulators and replace the heat-sink compound when replacing these transistors. The compound should be applied to both sides of the insulators and should be applied to the bottom side of the transistor where it comes in contact with the insulator.

### NOTE

*After replacing a power transistor, check that the collector is not shorted to the heat sink before applying power to the instrument.*

## SOLDERING TECHNIQUES

The reliability and accuracy of this instrument can be maintained only if proper soldering techniques are used to remove or replace parts. General soldering techniques, which apply to maintenance of any precision electronic equipment, should be used when working on this instrument.

### WARNING

*To avoid an electric-shock hazard, observe the following precautions before attempting any soldering: turn the instrument off, disconnect it from the ac power source, and allow approximately three minutes for the power-supply capacitors to discharge.*

Use rosin-core wire solder containing 63% tin and 37% lead. Contact your local Tektronix Field Office or representative to obtain the names of approved solder types.

When soldering on circuit boards or small insulated wires, use only a 15-watt, pencil-type soldering iron. A higher wattage soldering iron can cause etched circuit conductors to separate from the board base material and melt the insulation on small wires. Always keep the soldering-iron tip properly tinned to ensure best heat transfer from the iron tip to the solder joint. To protect heat-sensitive components, either hold the component lead with long-nose pliers or place a heat block between the component body and the solder joint. Apply only enough solder to make a firm joint. After soldering, clean the area around the solder connection with an approved flux-removing solvent (such as isopropyl alcohol) and allow it to air dry.

### CAUTION

*Attempts to unsolder, remove, and resolder leads from the component side of a circuit board may cause damage to the reverse side of the circuit board.*

The following techniques should be used to replace a component on any of the circuit boards:

1. Touch the vacuum desoldering tool to the lead at the solder connection. Never place the iron directly on the board; doing this may damage the board.

### NOTE

*Some components are difficult to remove from the circuit board due to a bend placed in each lead during machine insertion of the component. The purpose of the bent leads is to hold the component in place during a solder-flow manufacturing process that solders all the components at once. To make removal of machine-inserted components easier, straighten the component leads on the reverse side of the circuit board with a small screwdriver or pliers. It may be necessary to remove the circuit board to gain access to the component leads on the reverse side of the circuit board. Circuit-board removal and reinstallation procedures are discussed later in this section.*

2. When removing a multipin component, especially an IC, do not heat adjacent pins consecutively. Apply heat to pins at alternate sides and ends of the IC as solder is removed. Allow a moment for the circuit board to cool before proceeding to the next pin.

### CAUTION

*Excessive heat can cause the etched circuit conductors to separate from the circuit board. Never allow the solder extractor tip to remain at one place on the board for more than three seconds. Solder wick, spring-actuated or squeeze-bulb solder suckers, and heat blocks (for desoldering multipin components) must not be used. Damage caused by poor soldering techniques can void the instrument warranty.*

3. To replace the component, bend the leads of the replacement item to fit the holes in the circuit board. If the component is replaced while the board is installed in the instrument, cut the leads so they protrude only a small amount through the reverse side of the circuit board. Excess lead length may cause shorting to other conductive parts.

4. Insert the leads into the holes of the board so that the replacement component is positioned the same as the original component. Most components should be firmly seated against the circuit board.

5. Touch the soldering iron to the connection and apply enough solder to make a firm solder joint. Do not move the component while the solder hardens.

6. Cut off any excess lead protruding through the circuit board (if not clipped to size in step 3).

7. Clean the area around the solder connection with an approved flux-removing solvent. Be careful not to remove any of the printed information from the circuit board.

## REMOVAL AND REPLACEMENT INSTRUCTIONS

The exploded view drawings in the “Replaceable Mechanical Parts” list may be helpful during the removal and reinstallation of individual subassemblies or components. Circuit board and component locations are shown in the “Diagrams” section.

### Cabinet

#### WARNING

*To avoid electric shock, disconnect the instrument from the ac-power-input source before removing or replacing any component or assembly.*

To remove the instrument cabinet, perform the following steps:

1. Disconnect the instrument from its ac-power-input source.
2. On instruments with detachable power cords, disconnect the power cord from the instrument.
3. Remove the screw from the right rear side of the cabinet and two screws from the rear panel. Then remove the rear panel and, if applicable, feed the nondetachable power cord through the rear panel as the panel is removed.
4. Pull the front panel and attached chassis forward and out of the cabinet.

To reinstall the cabinet, perform the following steps:

5. Slide the chassis frame into the cabinet from the front until the cabinet is fully into the front-panel groove and the rear of the cabinet is flush with the rear of the chassis.
6. Feed the attached power cord (if applicable) through the hole in the rear panel. Align the rear-panel and side mounting holes with the screw holes in the chassis frame and reinstall the three screws removed in step 3.

#### CAUTION

*To ensure that the cabinet is grounded to the instrument chassis, the screw at the right rear side of the cabinet should be tightly secured.*

7. Reconnect the power cord (if disconnected in step 2).

### Cathode-Ray Tube

#### WARNING

*Use care when handling a crt. Breakage of the crt may cause high-velocity scattering of glass fragments (implosion). Protective clothing and safety glasses should be worn. Avoid striking the crt on any object which may cause it to crack or implode. When storing a crt, either place it in a protective carton or set it face down on a smooth surface in a protected location with a soft mat under the faceplate.*

To remove the crt, perform the following steps:

1. Disconnect four deflection-plate wires at the middle of the crt neck and unplug the Trace Rotation connector (P8006) from the Front-Panel circuit board (note the connection locations and wire color for reinstallation reference).

#### WARNING

*The crt anode and output terminal of the High-Voltage Multiplier will retain a high-voltage charge after the instrument is turned off. To avoid electrical shock, ground both the output terminal of the multiplier and the crt high-voltage anode lead to the main instrument chassis after disconnecting the high-voltage lead.*

2. Unplug the crt anode lead connector from the High-Voltage Multiplier at the front left corner of the High-Voltage shield and discharge it to the chassis.
3. Remove two screws that retain the plastic crt frame and light filter to the front panel. Remove the crt frame and light filter from the instrument.
4. With the rear of the instrument facing you, place the fingers of both hands over the front edge of the front subpanel. Then, using both thumbs, press forward gently on the crt funnel near the front of the crt. When the crt

## Maintenance—2215 Service

base pins disengage from the socket, remove the crt and crt shield through the instrument front subpanel. Place the crt in a safe place until it is ready to reinstall. If the plastic crt corner pads fall out, save them for reinstallation.

To reinstall the crt, perform the following steps:

5. Reinstall any plastic crt corner pads that may be out of place. Insert the crt, crt shield, anode lead, and Trace Rotation leads through the front-panel opening. Make sure all pins are straight and that the indexing keys on the crt base and socket are aligned. Make sure the crt shield ground clip only makes contact with the outside of the crt shield.

6. Push the crt base into the socket. Check that they are flush together as viewed from the rear and that the crt is seated properly in its front-panel opening.

7. Reinstall the crt frame and light filter; then secure them with two screws (removed in step 3).

8. Reconnect the crt anode lead to the High-Voltage Multiplier (disconnected in step 2).

9. Reconnect the four deflection-plate wires and the Trace Rotation connector (disconnected in step 1).

### High-Voltage Shield

To remove the High-Voltage shield, perform the following steps:

1. Remove the screw from the plastic high-voltage cover on the bottom section of the Main circuit board. Press gently on the rear of the cover and slide it forward.

2. Remove the screw securing the High-Voltage shield to the Main circuit board (located at the bottom of the circuit board near the right side of the frame).

3. Remove two screws securing the left rear of the High-Voltage shield to the back of the chassis frame.

4. Remove the screw from the front upper right-hand corner of the High-Voltage shield.

5. Remove the screw at the front upper left-hand corner and rotate the support bracket away from the High-Voltage shield.

6. Lift the shield up and out of the chassis frame by removing the right rear corner first.

To reinstall the High-Voltage shield, perform the following steps:

7. Insert the shield into the chassis frame. Make sure that the shield's right and back top edges are in their chassis frame guides, that the crt socket-wire assembly is in its cutout, and that the Alt Sweep board is in its plastic holder.

8. Rotate the support bracket back into place and secure it with the screw removed in step 5.

9. Reinstall the screw at the upper right-hand corner of the shield (removed in step 4).

10. Reinstall two screws securing the shield to the back of the chassis frame (removed in step 3).

11. Reinstall the screw holding the shield to the Main circuit board at the right side of the frame (removed in step 2).

12. Reinstall the plastic high-voltage cover on the bottom of the Main circuit board and secure the shield and cover with one screw (removed in step 1).

### Alt Sweep Circuit Board

To remove the Alt Sweep circuit board, perform the following steps:

1. Use a vacuum-desoldering tool to unsolder the 27 pins (which secure the Alt Sweep circuit board to the Main circuit board) from the Main circuit board.

2. Remove the Alt Sweep circuit board from the instrument by unclipping it from the plastic holder attached to the High-Voltage shield.

3. If component removal is desired, remove the two nuts which secure the shield to the Alt Sweep circuit board and remove the shield.

To reinstall the Alt Sweep circuit board, perform the following steps:

4. Reinstall the shield to the Alt Sweep circuit board (if previously removed in step 3).



5. Insert the 27 pins of the Alt Sweep circuit board into the Main circuit board.

6. Reinstall the Alt Sweep circuit board into the plastic holder attached to the High-Voltage shield.

7. Resolder the 27 pins to the Main circuit board (unsoldered in step 1).

### Attenuator/Sweep Circuit Board

To remove the Attenuator/Sweep circuit board, perform the following steps:

1. Use a 1/16-inch Allen wrench to loosen the set screws in the following knobs and remove the knobs: CH 1 and CH 2 VOLTS/DIV Variable and SEC/DIV Variable.

2. Set the CH 1 and CH 2 VOLTS/DIV switches to the same position; then remove their knobs by pulling straight out from the front panel. Note switch positions for reinstallation reference.

3. Use a 9/16-inch nut driver to remove the nuts securing the VOLTS/DIV switches to the front panel.

4. Lock the A and B SEC/DIV knobs together and note their position for reinstallation reference. Use a 1/4-inch nut driver to remove the nut and washers securing the B SEC/DIV knob; pull off the knob and collet from the shaft assembly.

5. Use a 1/16-inch Allen wrench to loosen the set screws which secure the A SEC/DIV dial to the shaft assembly.

6. Disconnect the following connectors from the Attenuator/Sweep circuit board:

- a. P1011, a four-wire connector located behind the CH 1 VOLTS/DIV switch assembly.
- b. P2011, a four-wire connector located behind the CH 2 VOLTS/DIV switch assembly.
- c. P7000, a seven-wire connector located on the rear edge of the circuit board.
- d. P6000, a ten-wire connector located on the right edge of the circuit board.

7. Remove three screws which secure the shield to the Main circuit board (located on the bottom of the Main circuit board).

8. Loosen but do not remove two screws securing the front of the shield to a bracket on the front panel. These screws are accessible from the bottom of the instrument through two holes along the front of the Main circuit board.

9. Pull the Attenuator/Sweep circuit board and shield assembly straight back from the front of the instrument until the circuit board interconnecting pins are disengaged and the switch shafts are clear of the holes in the Front-Panel circuit board. Then lift out the entire assembly through the top of the instrument.

10. If accessibility to the bottom of the Attenuator/Sweep circuit board is desired, remove three screws located at three corners of the circuit board and two screws from the bottom of the shield and separate the shield from the circuit board.

To reinstall the Attenuator/Sweep circuit board, perform the following steps:

11. If the shield has been removed, secure it to the Attenuator/Sweep circuit board using three screws (removed in step 10). Insert two screws in the bottom of the shield at the front edge (removed in step 10), but do not tighten them.

12. Insert the three switch shafts through the holes in the Front-Panel circuit board and the front panel. Carefully align the 10 interconnecting pins on the Front-Panel circuit board with their corresponding connectors on the Attenuator/Sweep circuit board. Push the board forward into position, ensuring that the two screws in the bottom shield engage the front-panel bracket.

13. Tighten two screws securing the shield to the front-panel bracket (loosened in step 8).

14. Reinstall three screws securing the shield to the Main circuit board (removed in step 7). Then tighten the two screws installed at the front edge of the shield in step 11.

15. Reconnect the four connectors to the Attenuator/Sweep circuit board that were disconnected in step 6.

## Maintenance—2215 Service

16. Reinstall two 9/16-inch nuts securing the VOLTS/DIV switch shafts to the front panel (removed in step 3).

17. Reinstall the two VOLTS/DIV knobs at the positions noted in step 2.

18. Reinstall the A SEC/DIV dial in the position noted in step 4 and secure it with two set screws loosened in step 5.

19. Reinstall the collet and B SEC/DIV knob (at the position noted in step 4) and secure it with the washers and nut (removed in step 4).

20. Rotate the three Variable control shafts fully clockwise to their calibrated detent positions.

21. Reinstall the Variable knobs onto their shafts (with the lettering horizontal and right-side up) and tighten their set screws.

### Front-Panel Circuit Board

To remove the Front-Panel circuit board, perform the following steps:

1. Remove the crt (see the “Cathode-Ray Tube” removal procedure).

2. Remove the Attenuator/Sweep circuit board (see the “Attenuator/Sweep Circuit Board” removal procedure).

3. Remove the knobs from the following control shafts by pulling them straight out from the front panel: Channel 1 and Channel 2 POSITION, A/B SWP SEP, Horizontal POSITION, AUTO FOCUS, AUTO INTENSITY, A TRIGGER LEVEL, and B TRIGGER LEVEL.

4. Unplug the three-wire B DELAY TIME POSITION potentiometer connector (P7055) from the Main circuit board (located in front of the High-Voltage shield).

5. Unsolder the resistors from the CH 1 OR X, CH 2 OR Y, and EXT INPUT connectors and disconnect the two-wire connector (P1000) from the Front-Panel circuit board to the PROBE ADJUST jack. Unsolder two wires (from the VAR HOLDOFF control) from the Front-Panel circuit board.

6. Remove two screws securing the Main circuit board to the left bottom side of the chassis frame.

7. Remove three screws securing the upper part of the Front-Panel circuit board to the front panel.

8. Remove four recessed frame-securing screws (two at the right front corner and two at the left rear corner of the frame).

9. Pull the front- and left-frame assembly apart from the rear- and right-frame assembly.

#### NOTE

*At this point, any component on the Front-Panel circuit board may be accessed for removal and replacement. Skip to step 12 of this procedure after component replacement. If circuit board replacement is intended, continue with the remaining disassembly steps.*

10. Use a vacuum-desoldering tool to unsolder the 39 wire straps from the Main circuit board which connect to the Front-Panel circuit board.

11. Remove the Front-Panel circuit board from the instrument and clean the wire-strap holes on the Main circuit board of any remaining solder.

#### NOTE

*If a vacuum-desoldering tool is not available, lift each strap out of the Main circuit board as its joint is heated.*

To reinstall the Front-Panel circuit board, perform the following steps:

12. Insert but do not solder the 39 wire straps on the Front-Panel circuit board into their corresponding holes in the Main circuit board (unsoldered in step 10).

13. Align the two frame assemblies disassembled in step 9, making sure the POWER extension-shaft button is in place in the front panel. Reinstall four frame-securing screws (removed in step 8).

14. Reinstall three screws securing the Front-Panel circuit board to the front panel (removed in step 7).

15. Reinstall two screws securing the left side of the Main circuit board to the frame (removed in step 6).

16. Resolder the resistors to the connectors (unsoldered in step 5) and reconnect the two-wire connector from the PROBE ADJUST jack to the Front-Panel circuit board (disconnected in step 5). Resolder the 39 wire straps on the Front-Panel circuit board to the Main circuit board. Resolder the two wires from the VAR HOLDOFF control (unsoldered in step 5).

17. Reconnect the three-wire B DELAY TIME POSITION potentiometer connector to the Main circuit board (removed in step 4).

18. Replace the front-panel knobs (removed in step 3).

19. Reinstall the Attenuator/Sweep circuit board (see the "Attenuator/Sweep Circuit Board" reinstallation procedure).

20. Reinstall the crt (see the "Cathode-Ray Tube" reinstallation procedure).

## Main Circuit Board

All components on the Main circuit board are accessible either directly or by removing the crt, Attenuator/Sweep circuit board, or High-Voltage shield. Removal of the Main circuit board is required only when it is necessary to replace the board with a new one.

To remove the Main circuit board, perform the following steps:

1. Remove the Attenuator/Sweep circuit board (see the "Attenuator/Sweep Circuit Board" removal procedure).

2. Disconnect the three-wire B DELAY TIME POSITION potentiometer connector (P7055) from the Main circuit board (located in front of the High-Voltage shield).

3. Remove the High-Voltage shield (see the "High-Voltage Shield" removal procedure).

4. Remove the Alt Sweep circuit board (see the "Alt Sweep Circuit Board" removal procedure).

5. Remove the AUTO FOCUS control-knob shaft assembly by pulling it straight out from the front panel.

6. Remove the POWER switch extension-shaft push button assembly by first pressing in the POWER button to the ON position. Insert a scribe or similar tool into the notch between the end of the switch shaft and the end of the extension shaft and gently pry the connection apart. Push the extension shaft forward, then sideways, to clear the switch shaft. Then pull the extension shaft back and out of the instrument.

7. Disconnect the leads of L925 (inductor), the lead of the fuse holder, the lead of the power-cord connector, and four leads (P801, P802, P803, and P804 from the Current Limit board) from the Main circuit board.

8. Unsolder the rear-panel EXT Z AXIS connector wire from the Main circuit board.

9. Unsolder two sets of crt socket wires from the Main circuit board, noting wire color and position for reinstallation reference.

10. Unsolder two sets of delay-line wires from the Main circuit board, noting wire color and position for reinstallation reference.

11. Remove two screws securing the power-supply transistor heat-sink assembly to the right side of the frame.

12. Remove three screws securing the Main circuit board to the instrument frame (one under the EXT Z AXIS connector and two along the left side of the Main circuit board).

13. Use a vacuum-desoldering tool to unsolder the 39 interconnecting wire straps (connecting the Main circuit board to the Front-Panel circuit board) from the Main circuit board.

### NOTE

*If a vacuum-desoldering tool is not available, lift each wire strap out of the Main circuit board as its joint is heated. Use care to maintain, as nearly as possible, the original shape and spacing of the wire straps to facilitate replacing the circuit board.*

14. Push the wire-strap connection end of the Main circuit board down until it is clear of the wire strap ends; then remove it through the bottom of the instrument frame. Ensure that the interconnecting wire straps are not bent out of place.

## Maintenance—2215 Service

15. Unsolder the delay-line holder tabs from the Main circuit board.

To replace the Main circuit board, use the following procedure:

16. Insert the delay-line holder tabs into the replacement circuit board and solder them in place. Ensure that the hole in the front tab and the mounting hole in the circuit board are aligned.

17. Place the Main circuit board into the chassis frame, ensuring that the board is in the guides at the rear and right side of the frame.

18. Reinstall three screws securing the Main circuit board to the frame (removed in step 12).

19. Reinstall two securing screws in the power-supply transistor heat-sink assembly (removed in step 11).

20. Move the front part of the Main circuit board into position. Align the 39 wire straps and insert them into their corresponding holes while maintaining their original shape and spacing.

21. Resolder the wire straps to the Main circuit board.

22. Resolder two sets of delay-line wires at the location noted in step 10.

23. Resolder two sets of crt socket wires at the locations noted in step 9.

24. Insert and resolder the EXT Z AXIS connector wire into the Main circuit board.

25. Reconnect the leads of L925 (inductor), the fuse holder, the power cord connector, and four wires from the Current Limit board (removed in step 7).

26. Insert the POWER switch extension-shaft push button assembly into the front panel (from the rear). Use a flat-bit screwdriver to hold the POWER switch shaft fully in and align the extension shaft with the switch shaft. Press them together gently until they snap into position.

27. Reinstall the AUTO FOCUS knob shaft assembly (removed in step 5).

28. Reinstall the High-Voltage shield (see the “High-Voltage Shield” reinstallation procedure).

29. Reconnect the B DELAY TIME POSITION potentiometer connector (P7055) to the Main circuit board (located in front of the High-Voltage shield).

30. Reinstall the Alt Sweep circuit board (see the “Alt Sweep Circuit Board” reinstallation procedure).

31. Reinstall the Attenuator/Sweep circuit board (see the “Attenuator/Sweep Circuit Board” reinstallation procedure).

## Current Limit Circuit Board

To remove the Current Limit board, perform the following steps:

1. Remove the High-Voltage shield (see the “High-Voltage Shield” removal procedure).

2. Disconnect the four single-wire connectors from the Current Limit board (P801, P802, P803, and P804).

3. Remove the screw and nut which secure the Current Limit board to the chassis frame.

To reinstall the Current Limit board, perform the following steps:

4. Reinstall the securing screw and nut (removed in step 3).

5. Reconnect the four single-wire connectors (removed in step 2).

6. Reinstall the High-Voltage shield (see the “High-Voltage Shield” reinstallation procedure).

## REPACKAGING FOR SHIPMENT

If the instrument is to be shipped to a Tektronix Service Center for service or repair, attach a tag showing: owner (with address) and the name of an individual at your firm that can be contacted. Include complete instrument serial number and a description of the service required. Listings of Tektronix Sales and Service offices, both domestic and international, are located at the back of the manual following the tabbed "Accessories" page.

Save and reuse the package in which your instrument was shipped. If the original packaging is unfit for use or not available, repackage the instrument as follows:

Surround the instrument with polyethylene sheeting to protect its finish. Obtain a carton of corrugated cardboard having a carton test strength of 275 pounds and having inside dimensions of no less than six inches more than the instrument dimensions. Cushion the instrument by tightly packing three inches of dunnage or urethane foam between carton and instrument, on all sides. Seal carton with shipping tape or industrial stapler.

# OPTIONS

There are currently no options available for the 2215, except the optional power cords previously described in Section 2.

# REPLACEABLE ELECTRICAL PARTS

## PARTS ORDERING INFORMATION

Replacement parts are available from or through your local Tektronix, Inc. Field Office or representative.

Changes to Tektronix instruments are sometimes made to accommodate improved components as they become available, and to give you the benefit of the latest circuit improvements developed in our engineering department. It is therefore important, when ordering parts, to include the following information in your order: Part number, instrument type or number, serial number, and modification number if applicable.

If a part you have ordered has been replaced with a new or improved part, your local Tektronix, Inc. Field Office or representative will contact you concerning any change in part number.

Change information, if any, is located at the rear of this manual.

### LIST OF ASSEMBLIES

A list of assemblies can be found at the beginning of the Electrical Parts List. The assemblies are listed in numerical order. When the complete component number of a part is known, this list will identify the assembly in which the part is located.

### CROSS INDEX-MFR. CODE NUMBER TO MANUFACTURER

The Mfr. Code Number to Manufacturer index for the Electrical Parts List is located immediately after this page. The Cross Index provides codes, names and addresses of manufacturers of components listed in the Electrical Parts List.

### ABBREVIATIONS

Abbreviations conform to American National Standard Y1.1.

### COMPONENT NUMBER (column one of the Electrical Parts List)

A numbering method has been used to identify assemblies, subassemblies and parts. Examples of this numbering method and typical expansions are illustrated by the following:

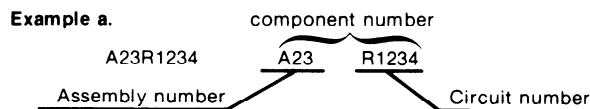

**Read: Resistor 1234 of Assembly 23**

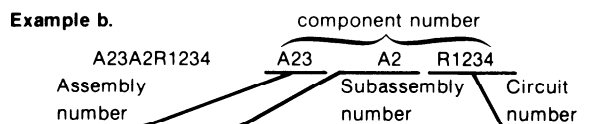

**Read: Resistor 1234 of Subassembly 2 of Assembly 23**

Only the circuit number will appear on the diagrams and circuit board illustrations. Each diagram and circuit board illustration is clearly marked with the assembly number. Assembly numbers are also marked on the mechanical exploded views located in the Mechanical Parts List. The component number is obtained by adding the assembly number prefix to the circuit number.

The Electrical Parts List is divided and arranged by assemblies in numerical sequence (e.g., assembly A1 with its subassemblies and parts, precedes assembly A2 with its subassemblies and parts).

Chassis-mounted parts have no assembly number prefix and are located at the end of the Electrical Parts List.

### TEKTRONIX PART NO. (column two of the Electrical Parts List)

Indicates part number to be used when ordering replacement part from Tektronix.

### SERIAL/MODEL NO. (columns three and four of the Electrical Parts List)

Column three (3) indicates the serial number at which the part was first used. Column four (4) indicates the serial number at which the part was removed. No serial number entered indicates part is good for all serial numbers.

### NAME & DESCRIPTION (column five of the Electrical Parts List)

In the Parts List, an Item Name is separated from the description by a colon (:). Because of space limitations, an Item Name may sometimes appear as incomplete. For further Item Name identification, the U.S. Federal Cataloging Handbook H6-1 can be utilized where possible.

### MFR. CODE (column six of the Electrical Parts List)

Indicates the code number of the actual manufacturer of the part. (Code to name and address cross reference can be found immediately after this page.)

### MFR. PART NUMBER (column seven of the Electrical Parts List)

Indicates actual manufacturers part number.

CROSS INDEX—MFR. CODE NUMBER TO MANUFACTURER

Mfr. Code	Manufacturer	Address	City, State, Zip
000FG	RIFA WORLD PRODUCTS INC.	7625 BUSH LAKE RD P.O. BOX 35263	MINNEAPOLIS, MN 55435
000IQ	HVC CORP. INC.	600 SOUTH MILWAUKEE ST.	FREDONIA, WI 53021
00779	AMP, INC.	P O BOX 3608	HARRISBURG, PA 17105
00853	SANGAMO ELECTRIC CO., S. CAROLINA DIV.	P O BOX 128	PICKENS, SC 29671
01121	ALLEN-BRADLEY COMPANY	1201 2ND STREET SOUTH	MILWAUKEE, WI 53204
01281	TRW ELECTRONIC COMPONENTS, SEMICONDUCTOR OPERATIONS	14520 AVIATION BLVD.	LAWDALE, CA 90260
01295	TEXAS INSTRUMENTS, INC., SEMICONDUCTOR GROUP	P O BOX 5012, 13500 N CENTRAL EXPRESSWAY	DALLAS, TX 75222
02111	SPECTROL ELECTRONICS CORPORATION	17070 EAST GALE AVENUE	CITY OF INDUSTRY, CA 91745
02113	COILCRAFT INC.	1102 SILVER LAKE RD.	CARY, IL 60013
02114	FERROXCUBE CORPORATION	PO BOX 359, MARION ROAD	SAUGERTIES, NY 12477
02735	RCA CORPORATION, SOLID STATE DIVISION	ROUTE 202	SOMERVILLE, NY 08876
03508	GENERAL ELECTRIC COMPANY, SEMI-CONDUCTOR PRODUCTS DEPARTMENT	ELECTRONICS PARK	SYRACUSE, NY 13201
04222	AVX CERAMICS, DIVISION OF AVX CORP.	P O BOX 867, 19TH AVE. SOUTH	MYRTLE BEACH, SC 29577
04713	MOTOROLA, INC., SEMICONDUCTOR PROD. DIV.	5005 E MCDOWELL RD, PO BOX 20923	PHOENIX, AZ 85036
05347	ULTRONIX, INC.	461 N 22ND STREET	GRAND JUNCTION, CO 81501
05828	GENERAL INSTRUMENT CORP ELECTRONIC SYSTEMS DIV.	600 W JOHN ST.	HICKSVILLE LI, NY 11802
07263	FAIRCHILD SEMICONDUCTOR, A DIV. OF FAIRCHILD CAMERA AND INSTRUMENT CORP.	464 ELLIS STREET	MOUNTAIN VIEW, CA 94042
12697	CLAROSTAT MFG. CO., INC.	LOWER WASHINGTON STREET	DOVER, NH 03820
12969	UNITRODE CORPORATION	580 PLEASANT STREET	WATERTOWN, MA 02172
13511	AMPHENOL CARDRE DIV., BUNKER RAMO CORP.		LOS GATOS, CA 95030
14099	SEMTECH CORP.	652 MITCHELL RD.	NEWBURY PARK, CA 91320
14552	MICRO SEMICONDUCTOR CORP.	2830 E FAIRVIEW ST.	SANTA ANA, CA 92704
15238	ITT SEMICONDUCTORS, A DIVISION OF INTER NATIONAL TELEPHONE AND TELEGRAPH CORP.	P.O. BOX 168, 500 BROADWAY	LAWRENCE, MA 01841
18324	SIGNETICS CORP.	811 E. ARQUES	SUNNYVALE, CA 94086
19396	ILLINOIS TOOL WORKS, INC. PAKTRON DIV.	900 FOLLIN LANE, SE	VIENNA, VA 22180
20932	EMCON DIV OF ILLINOIS TOOL WORKS INC.	11620 SORRENTO VALLEY RD P O BOX 81542	SAN DIEGO, CA 92121
22229	SOLITRON DEVICES, INC., SEMICONDUCTOR GROUP	8808 BALBOA AVENUE	SAN DIEGO OPERS, CA 92123
22526	BERG ELECTRONICS, INC.	YOUK EXPRESSWAY	NEW CUMBERLAND, PA 17070
24444	GENERAL SEMICONDUCTOR INDUSTRIES INC.	2001 W 10TH PLACE P.O. BOX 3078	TEMPE, AZ 85281
24546	CORNING GLASS WORKS, ELECTRONIC COMPONENTS DIVISION	550 HIGH STREET	BRADFORD, PA 16701
27014	NATIONAL SEMICONDUCTOR CORP.	2900 SEMICONDUCTOR DR.	SANTA CLARA, CA 95051
31918	IEE/SCHADOW INC.	8081 WALLACE ROAD	EDEN PRAIRIE, MN 55343
32997	BOURNS, INC., TRIMPOT PRODUCTS DIV.	1200 COLUMBIA AVE.	RIVERSIDE, CA 92507
50157	MIDWEST COMPONENTS INC.	P. O. BOX 787 1981 PORT CITY BLVD.	MUSKEGON, MI 49443
50434	HEWLETT-PACKARD COMPANY	640 PAGE MILL ROAD	PALO ALTO, CA 94304
51642	CENTRE ENGINEERING INC.	2820 E COLLEGE AVENUE	STATE COLLEGE, PA 16801
52769	SPRAGUE GOODMAN ELEC., INC.	134 FULTON AVENUE	GARDEN CITY PARK, NY 11040
53184	KCITON CORPORATION	5 HEMLOCK STREET	LATHAM, NY 12110
53944	ELT INC., GLOW LITE DIVISION	BOX 698	PAULS VALLEY, OK 73075
54473	MATSUSHITA ELECTRIC, CORP. OF AMERICA	1 PANASONIC WAY	SECAUCUS, NJ 07094
54937	DEYOUNG MFG., INC.	PO BOX 1806, 1517 130TH AVE.	BELLEVUE, WA 98009
55210	GETTIG ENG. AND MFG. COMPANY	PO BOX 85, OFF ROUTE 45	SPRING MILLS, PA 16875
55680	NICHICON/AMERICA/CORP.	6435 N PROESEL AVENUE	CHICAGO, IL 60645
56289	SPRAGUE ELECTRIC CO.	87 MARSHALL ST.	NORTH ADAMS, MA 01247
59660	TUSONIX INC.	2155 N FORBES BLVD	TUCSON, AZ 85705
71400	BUSSMAN MFG., DIVISION OF MCGRAW-EDISON CO.	2536 W. UNIVERSITY ST.	ST. LOUIS, MO 63107
72982	ERIE TECHNOLOGICAL PRODUCTS, INC.	644 W. 12TH ST.	ERIE, PA 16512
73138	BECKMAN INSTRUMENTS, INC., HELIPOT DIV.	2500 HARBOR BLVD.	FULLERTON, CA 92634
73899	JFD ELECTRONICS COMPONENTS CORP.	PINETREE ROAD	OXFORD, NC 27565
74970	JOHNSON, E. F., CO.	299 10TH AVE. S. W.	WASECA, MN 56093
75042	TRW ELECTRONIC COMPONENTS, IRC FIXED RESISTORS, PHILADELPHIA DIVISION	401 N. BROAD ST.	PHILADELPHIA, PA 19108



CROSS INDEX—MFR. CODE NUMBER TO MANUFACTURER

Mfr. Code	Manufacturer	Address	City, State, Zip
77820	BENDIX CORP., THE, ELECTRICAL COMPONENTS DIVISION	SHERMAN AVE.	SIDNEY, NY 13838
80009	TEKTRONIX, INC.	P O BOX 500	BEAVERTON, OR 97077
80031	ELECTRA-MIDLAND CORP., MEPCO DIV.	22 COLUMBIA ROAD	MORRISTOWN, NJ 07960
81483	INTERNATIONAL RECTIFIER CORP.	9220 SUNSET BLVD.	LOS ANGELES, CA 90069
82389	SWITCHCRAFT, INC.	5555 N. ELSTON AVE.	CHICAGO, IL 60630
84411	TRW ELECTRONIC COMPONENTS, TRW CAPACITORS	112 W. FIRST ST.	OGALLALA, NE 69153
90201	MALLORY CAPACITOR CO., DIV. OF P. R. MALLORY AND CO., INC.	3029 E. WASHINGTON STREET P. O. BOX 372	INDIANAPOLIS, IN 46206
91418	RADIO MATERIALS COMPANY, DIV. OF P.R. MALLORY AND COMPANY, INC.	4242 W BRYN MAWR	CHICAGO, IL 60646
91637	DALE ELECTRONICS, INC.	P. O. BOX 609	COLUMBUS, NE 68601
99392	MEMPCO/ELECTRA INC., ROXBORO DIV.	P O BOX 1223	ROXBORO, NC 27573

Replaceable Electrical Parts—2215 Service

Component No.	Tektronix Part No.	Serial/Model No. Eff Dscont	Name & Description	Mfr Code	Mfr Part Number
A10	670-6866-00		CKT BOARD ASSY:MAIN	80009	670-6866-00
A11	670-6867-00		CKT BOARD ASSY:FRONT PANEL	80009	670-6867-00
A12	670-6868-00		CKT BOARD ASSY:ATTEN/SWEEP	80009	670-6868-00
A13	670-6869-00		CKT BOARD ASSY:ALTERNATE SWEEP	80009	670-6869-00
A19	670-7498-00		CKT BOARD ASSY:CURRENT LIMIT	80009	670-7498-00
A10	-----		CKT BOARD ASSY:MAIN		
A10C167	281-0064-00		CAP.,VAR,PLSTC:0.25-1.5PF,600V	74970	273-0001-301
A10C170	281-0862-00		CAP.,FXD,CER DI:0.001UF,+80-20%,100V	20932	401-ES-100-AD102
A10C173	281-0814-00		CAP.,FXD,CER DI:100PF,10%,100V	04222	GC70-1-A101K
A10C174	283-0154-00	B010100 B011399	CAP.,FXD,CER DI:22PF,5%,50V	72982	8111B061COG220J
A10C174	281-0759-00	B011400	CAP.,FXD,CER DI:22PF,10%,100V	72982	8035D9AADC1G220K
A10C175	281-0791-00		CAP.,FXD,CER DI:270PF,10%,100V	72982	8035D2AADX5R271K
A10C179	281-0823-00		CAP.,FXD,CER DI:470PF,10%,50V	12969	CGB471KDN
A10C180	283-0648-00		CAP.,FXD,MICA D:10PF,5%,100V	00853	D151C100D0
A10C185	281-0791-00		CAP.,FXD,CER DI:270PF,10%,100V	72982	8035D2AADX5R271K
A10C193	281-0862-00		CAP.,FXD,CER DI:0.001UF,+80-20%,100V	20932	401-ES-100-AD102
A10C199	290-0136-00		CAP.,FXD,ELCTLT:2.2UF,20%,20V	56289	162D225X0020CD2
A10C253	281-0862-00		CAP.,FXD,CER DI:0.001UF,+80-20%,100V	20932	401-ES-100-AD102
A10C255	281-0773-00		CAP.,FXD,CER DI:0.01UF,10%,100V	04222	GC70-1C103K
A10C260	281-0773-00		CAP.,FXD,CER DI:0.01UF,10%,100V	04222	GC70-1C103K
A10C264	283-0084-00		CAP.,FXD,CER DI:270PF,5%,1000V	72982	838-533B271J
A10C265	281-0773-00	XB011400	CAP.,FXD,CER DI:0.01UF,10%,100V	04222	GC70-1C103K
A10C270	281-0862-00		CAP.,FXD,CER DI:0.001UF,+80-20%,100V	20932	401-ES-100-AD102
A10C273	281-0814-00		CAP.,FXD,CER DI:100PF,10%,100V	04222	GC70-1-A101K
A10C275	281-0791-00		CAP.,FXD,CER DI:270PF,10%,100V	72982	8035D2AADX5R271K
A10C279	281-0823-00		CAP.,FXD,CER DI:470PF,10%,50V	12969	CGB471KDN
A10C280	283-0648-00		CAP.,FXD,MICA D:10PF,5%,100V	00853	D151C100D0
A10C284	283-0154-00	B010100 B011399	CAP.,FXD,CER DI:22PF,5%,50V	72982	8111B061COG220J
A10C284	281-0759-00	B011400	CAP.,FXD,CER DI:22PF,10%,100V	72982	8035D9AADC1G220K
A10C285	281-0791-00		CAP.,FXD,CER DI:270PF,10%,100V	72982	8035D2AADX5R271K
A10C293	281-0862-00		CAP.,FXD,CER DI:0.001UF,+80-20%,100V	20932	401-ES-100-AD102
A10C299	290-0136-00		CAP.,FXD,ELCTLT:2.2UF,20%,20V	56289	162D225X0020CD2
A10C304	281-0773-00		CAP.,FXD,CER DI:0.01UF,10%,100V	04222	GC70-1C103K
A10C305	290-0167-00		CAP.,FXD,ELCTLT:10UF,20%,15V	56289	150D106X0015B2
A10C308	285-0643-00		CAP.,FXD,PLSTC:0.0047UF,5%,100V	56289	410P374
A10C310	281-0775-00		CAP.,FXD,CER DI:0.1UF,20%,50V	72982	8005D9AABZ5U104M
A10C311	281-0862-00		CAP.,FXD,CER DI:0.001UF,+80-20%,100V	20932	401-ES-100-AD102
A10C316	281-0862-00		CAP.,FXD,CER DI:0.001UF,+80-20%,100V	20932	401-ES-100-AD102
A10C317	281-0775-00		CAP.,FXD,CER DI:0.1UF,20%,50V	72982	8005D9AABZ5U104M
A10C319	281-0823-00		CAP.,FXD,CER DI:470PF,10%,50V	12969	CGB471KDN
A10C335	281-0810-00		CAP.,FXD,CER DI:5.6PF,0.5%,100V	72982	1035D2ADCOG569D
A10C340	281-0645-00		CAP.,FXD,CER DI:8.2PF,+/-0.25PF,500V	59660	374 018 C0H0829C
A10C345	281-0810-00		CAP.,FXD,CER DI:5.6PF,0.5%,100V	72982	1035D2ADCOG569D
A10C350	281-0823-00		CAP.,FXD,CER DI:470PF,10%,50V	12969	CGB471KDN
A10C357	281-0226-00		CAP.,VAR,PLSTC:5.5-65PF,100V	52769	GXD38000
A10C358	281-0767-00		CAP.,FXD,CER DI:330PF,20%,100V	12969	CGB331MEX
A10C360	281-0823-00		CAP.,FXD,CER DI:470PF,10%,50V	12969	CGB471KDN
A10C366	281-0234-00		CAP.,VAR,PLSTC:5.5-65PF,100V	80031	2810C5R565UJ02F
A10C367	281-0814-00		CAP.,FXD,CER DI:100PF,10%,100V	04222	GC70-1-A101K
A10C368	283-0051-00		CAP.,FXD,CER DI:0.0033UF,5%,100V	72982	8131N145COG0332J
A10C374	290-0187-00		CAP.,FXD,ELCTLT:4.7UF,20%,35V	56289	150D475X0035B2
A10C377	283-0348-00		CAP.,FXD,CER DI:0.5PF,+/-0.1PF,100V	51642	100-100-NP0-508B
A10C387	283-0348-00		CAP.,FXD,CER DI:0.5PF,+/-0.1PF,100V	51642	100-100-NP0-508B
A10C394	281-0775-00		CAP.,FXD,CER DI:0.1UF,20%,50V	72982	8005D9AABZ5U104M

Component No.	Tektronix Part No.	Serial/Model No. Eff Dscnt	Name & Description	Mfr Code	Mfr Part Number
A10C399	281-0773-00		CAP., FXD, CER DI:0.01UF, 10%, 100V	04222	GC70-1C103K
A10C408	281-0808-00		CAP., FXD, CER DI:7PF, 20%, 100V	72982	8035D9AADC0G709G
A10C410	281-0862-00		CAP., FXD, CER DI:0.001UF, +80-20%, 100V	20932	401-ES-100-AD102
A10C412	281-0773-00		CAP., FXD, CER DI:0.01UF, 10%, 100V	04222	GC70-1C103K
A10C417	281-0862-00		CAP., FXD, CER DI:0.001UF, +80-20%, 100V	20932	401-ES-100-AD102
A10C418	281-0823-00		CAP., FXD, CER DI:470PF, 10%, 50V	12969	CGB471KDN
A10C431	281-0773-00		CAP., FXD, CER DI:0.01UF, 10%, 100V	04222	GC70-1C103K
A10C432	281-0773-00		CAP., FXD, CER DI:0.01UF, 10%, 100V	04222	GC70-1C103K
A10C433	281-0862-00		CAP., FXD, CER DI:0.001UF, +80-20%, 100V	20932	401-ES-100-AD102
A10C437	281-0862-00		CAP., FXD, CER DI:0.001UF, +80-20%, 100V	20932	401-ES-100-AD102
A10C438	281-0862-00		CAP., FXD, CER DI:0.001UF, +80-20%, 100V	20932	401-ES-100-AD102
A10C446	281-0547-00		CAP., FXD, CER DI:2.7PF, 10%, 500V	04222	7001-1321
A10C447	285-1189-00		CAP., FXD, MTLZD:0.1UF, 5%, 100V	99392	C280MAH/J100K
A10C448	281-0775-00		CAP., FXD, CER DI:0.1UF, 20%, 50V	72982	8005D9AABZ5U104M
A10C454	281-0773-00		CAP., FXD, CER DI:0.01UF, 10%, 100V	04222	GC70-1C103K
A10C455	281-0862-00		CAP., FXD, CER DI:0.001UF, +80-20%, 100V	20932	401-ES-100-AD102
A10C457	281-0773-00		CAP., FXD, CER DI:0.01UF, 10%, 100V	04222	GC70-1C103K
A10C458	281-0773-00		CAP., FXD, CER DI:0.01UF, 10%, 100V	04222	GC70-1C103K
A10C476	281-0773-00		CAP., FXD, CER DI:0.01UF, 10%, 100V	04222	GC70-1C103K
A10C477	281-0773-00		CAP., FXD, CER DI:0.01UF, 10%, 100V	04222	GC70-1C103K
A10C480	281-0773-00		CAP., FXD, CER DI:0.01UF, 10%, 100V	04222	GC70-1C103K
A10C503	290-0246-00		CAP., FXD, ELCTLT:3.3UF, 10%, 15V	56289	162D335X9015CD2
A10C504	290-0246-00		CAP., FXD, ELCTLT:3.3UF, 10%, 15V	56289	162D335X9015CD2
A10C505	281-0773-00		CAP., FXD, CER DI:0.01UF, 10%, 100V	04222	GC70-1C103K
A10C506	283-0177-00		CAP., FXD, CER DI:1UF, +80-20%, 25V	56289	273C5
A10C564	281-0773-00		CAP., FXD, CER DI:0.01UF, 10%, 100V	04222	GC70-1C103K
A10C569	281-0773-00		CAP., FXD, CER DI:0.01UF, 10%, 100V	04222	GC70-1C103K
A10C601	281-0774-00		CAP., FXD, CER DI:0.022UF, 20%, 100V	12969	CGE223MEZ
A10C602	281-0862-00		CAP., FXD, CER DI:0.001UF, +80-20%, 100V	20932	401-ES-100-AD102
A10C603	281-0775-00		CAP., FXD, CER DI:0.1UF, 20%, 50V	72982	8005D9AABZ5U104M
A10C604	281-0775-00		CAP., FXD, CER DI:0.1UF, 20%, 50V	72982	8005D9AABZ5U104M
A10C605	281-0775-00		CAP., FXD, CER DI:0.1UF, 20%, 50V	72982	8005D9AABZ5U104M
A10C606	281-0862-00		CAP., FXD, CER DI:0.001UF, +80-20%, 100V	20932	401-ES-100-AD102
A10C607	281-0862-00		CAP., FXD, CER DI:0.001UF, +80-20%, 100V	20932	401-ES-100-AD102
A10C608	281-0775-00		CAP., FXD, CER DI:0.1UF, 20%, 50V	72982	8005D9AABZ5U104M
A10C610	281-0775-00		CAP., FXD, CER DI:0.1UF, 20%, 50V	72982	8005D9AABZ5U104M
A10C614	290-0135-00		CAP., FXD, ELCTLT:15UF, 20%, 20V	56289	150D156X0020B2
A10C618	281-0773-00		CAP., FXD, CER DI:0.01UF, 10%, 100V	04222	GC70-1C103K
A10C619	281-0791-00	B010100 B011229X	CAP., FXD, CER DI:270PF, 10%, 100V	72982	8035D2AADX5R271K
A10C637	281-0810-00		CAP., FXD, CER DI:5.6PF, 0.5%, 100V	72982	1035D2ADC0G569D
A10C640	281-0775-00		CAP., FXD, CER DI:0.1UF, 20%, 50V	72982	8005D9AABZ5U104M
A10C642	281-0770-00		CAP., FXD, CER DI:0.001UF, 20%, 100V	72982	8035D9AADX5R102M
A10C644	281-0770-00		CAP., FXD, CER DI:0.001UF, 20%, 100V	72982	8035D9AADX5R102M
A10C645	290-0167-00		CAP., FXD, ELCTLT:10UF, 20%, 15V	56289	150D106X0015B2
A10C646	281-0775-00		CAP., FXD, CER DI:0.1UF, 20%, 50V	72982	8005D9AABZ5U104M
A10C647	281-0772-00		CAP., FXD, CER DI:0.0047UF, 10%, 100V	04222	GC701C472K
A10C648	281-0773-00		CAP., FXD, CER DI:0.01UF, 10%, 100V	04222	GC70-1C103K
A10C651	281-0773-00		CAP., FXD, CER DI:0.01UF, 10%, 100V	04222	GC70-1C103K
A10C658	290-0745-00	B010100 B010684X	CAP., FXD, ELCTLT:22UF, +50-10%, 25V	56289	502D225
A10C668	281-0814-00		CAP., FXD, CER DI:100PF, 10%, 100V	04222	GC70-1-A101K
A10C678	281-0773-00		CAP., FXD, CER DI:0.01UF, 10%, 100V	04222	GC70-1C103K
A10C702	281-0775-00		CAP., FXD, CER DI:0.1UF, 20%, 50V	72982	8005D9AABZ5U104M
A10C708	281-0592-00		CAP., FXD, CER DI:4.7PF, +/-0.5PF, 500V	59660	301-023COH0479D
A10C725	290-0745-00		CAP., FXD, ELCTLT:22UF, +50-10%, 25V	56289	502D225
A10C745	281-0775-00		CAP., FXD, CER DI:0.1UF, 20%, 50V	72982	8005D9AABZ5U104M
A10C748	281-0775-00		CAP., FXD, CER DI:0.1UF, 20%, 50V	72982	8005D9AABZ5U104M
A10C754	281-0158-00		CAP., VAR, CER DI:7-45PF, 50V	73899	DVJ-5006

Replaceable Electrical Parts—2215 Service

Component No.	Tektronix Part No.	Serial/Model No. Eff Dscont	Name & Description	Mfr Code	Mfr Part Number
A10C770	283-0198-00		CAP., FXD, CER DI:0.22UF, 20%, 50V	72982	8121N083Z5U0224M
A10C773	283-0158-00		CAP., FXD, CER DI:1PF, 10%, 50V	72982	8101B057C0K0109B
A10C774	281-0214-00		CAP., VAR, CER DI:0.5-3PF, 400V	80031	2502A0R503VP02F0
A10C777	281-0771-00		CAP., FXD, CER DI:0.0022UF, 20%, 200V	56289	292C Z5U222M200B
A10C779	285-1101-00		CAP., FXD, PLSTC:0.022UF, 10%, 200V	19396	223K02PT485
A10C781	281-0775-00		CAP., FXD, CER DI:0.1UF, 20%, 50V	72982	8005D9AABZ5U104M
A10C783	283-0158-00		CAP., FXD, CER DI:1PF, 10%, 50V	72982	8101B057C0K0109B
A10C784	281-0214-00		CAP., VAR, CER DI:0.5-3PF, 400V	80031	2502A0R503VP02F0
A10C787	281-0771-00		CAP., FXD, CER DI:0.0022UF, 20%, 200V	56289	292C Z5U222M200B
A10C789	285-1101-00		CAP., FXD, PLSTC:0.022UF, 10%, 200V	19396	223K02PT485
A10C796	281-0775-00		CAP., FXD, CER DI:0.1UF, 20%, 50V	72982	8005D9AABZ5U104M
A10C797	281-0775-00		CAP., FXD, CER DI:0.1UF, 20%, 50V	72982	8005D9AABZ5U104M
A10C798	281-0775-00		CAP., FXD, CER DI:0.1UF, 20%, 50V	72982	8005D9AABZ5U104M
A10C799	283-0057-00		CAP., FXD, CER DI:0.1UF, +80-20%, 200V	56289	274C10
A10C803	281-0820-00		CAP., FXD, CER DI:680PF, 10%, 50V	12969	CGB681KDX
A10C810	281-0773-00	XB010685	CAP., FXD, CER DI:0.01UF, 10%, 100V	04222	GC70-1C103K
A10C820	281-0773-00		CAP., FXD, CER DI:0.01UF, 10%, 100V	04222	GC70-1C103K
A10C821	290-0183-00		CAP., FXD, ELCTLT:1UF, 10%, 35V	90201	TAC105K035P02
A10C822	281-0775-00		CAP., FXD, CER DI:0.1UF, 20%, 50V	72982	8005D9AABZ5U104M
A10C824	281-0773-00		CAP., FXD, CER DI:0.01UF, 10%, 100V	04222	GC70-1C103K
A10C825	290-0183-00		CAP., FXD, ELCTLT:1UF, 10%, 35V	90201	TAC105K035P02
A10C834	281-0756-00		CAP., FXD, CER DI:2.2PF, 0.5%, 200V	12969	CGB2R2DFN
A10C836	281-0773-00		CAP., FXD, CER DI:0.01UF, 10%, 100V	04222	GC70-1C103K
A10C840	281-0775-00		CAP., FXD, CER DI:0.1UF, 20%, 50V	72982	8005D9AABZ5U104M
A10C841	281-0773-00		CAP., FXD, CER DI:0.01UF, 10%, 100V	04222	GC70-1C103K
A10C842	281-0775-00		CAP., FXD, CER DI:0.1UF, 20%, 50V	72982	8005D9AABZ5U104M
A10C844	281-0862-00		CAP., FXD, CER DI:0.001UF, +80-20%, 100V	20932	401-ES-100-AD102
A10C845	281-0775-00		CAP., FXD, CER DI:0.1UF, 20%, 50V	72982	8005D9AABZ5U104M
A10C847	281-0775-00		CAP., FXD, CER DI:0.1UF, 20%, 50V	72982	8005D9AABZ5U104M
A10C848	281-0775-00		CAP., FXD, CER DI:0.1UF, 20%, 50V	72982	8005D9AABZ5U104M
A10C849	283-0057-00		CAP., FXD, CER DI:0.1UF, +80-20%, 200V	56289	274C10
A10C852	283-0057-00		CAP., FXD, CER DI:0.1UF, +80-20%, 200V	56289	274C10
A10C854	283-0057-00		CAP., FXD, CER DI:0.1UF, +80-20%, 200V	56289	274C10
A10C861	283-0057-00		CAP., FXD, CER DI:0.1UF, +80-20%, 200V	56289	274C10
A10C863	281-0791-00		CAP., FXD, CER DI:270PF, 10%, 100V	72982	8035D2AADX5R271K
A10C864	283-0279-00		CAP., FXD, CER DI:0.001UF, 20%, 3000V	56289	55C153
A10C865	283-0430-00		CAP., FXD, CER DI:0.02UF, +80-20%, 3000V	000IQ	HV0309
A10C871	283-0057-00		CAP., FXD, CER DI:0.1UF, +80-20%, 200V	56289	274C10
A10C873	283-0057-00		CAP., FXD, CER DI:0.1UF, +80-20%, 200V	56289	274C10
A10C876	283-0057-00		CAP., FXD, CER DI:0.1UF, +80-20%, 200V	56289	274C10
A10C877	283-0057-00		CAP., FXD, CER DI:0.1UF, +80-20%, 200V	56289	274C10
A10C878	283-0109-00		CAP., FXD, CER DI:27PF, 5%, 1000V	56289	20C376
A10C879	283-0109-00		CAP., FXD, CER DI:27PF, 5%, 1000V	56289	20C376
A10C886	283-0057-00		CAP., FXD, CER DI:0.1UF, +80-20%, 200V	56289	274C10
A10C901	285-1196-00		CAP., FXD, PAPER:0.01UF, 20%, 250V	84411	PME 271 Y 510
A10C912	281-0770-00		CAP., FXD, CER DI:0.001UF, 20%, 100V	72982	8035D9AADX5R102M
A10C915	290-0188-00		CAP., FXD, ELCTLT:0.1UF, 10%, 35V	56289	162D104X9035BC2
A10C917	290-0808-00		CAP., FXD, ELCTLT:2.7UF, 10%, 20V	56289	162D275X9020CD2
A10C926	285-1222-00		CAP., FXD, PLSTC:0.068UF, 20%, 250V	000FG	PME271M568
A10C937	290-0507-00		CAP., FXD, ELCTLT:1800UF, +75-10%, 75V	56289	68D10472
A10C945	290-0766-00	XB011000	CAP., FXD, ELCTLT:2.2UF, +50-10%, 160V	54473	ECEA2CS2R2
A10C947	290-0972-00	XB012543	CAP., FXD, ELCTLT:33UF, 20%, 50VDC	55680	TLB1H330M
A10C951	290-0768-00		CAP., FXD, ELCTLT:10UF, +50-10%, 100V	54473	ECE-A100V10L
A10C956	281-0775-00		CAP., FXD, CER DI:0.1UF, 20%, 50V	72982	8005D9AABZ5U104M
A10C957	290-0183-00		CAP., FXD, ELCTLT:1UF, 10%, 35V	90201	TAC105K035P02
A10C961	290-0947-00		CAP., FXD, ELCTLT:33UF, +50-10%, 160V	55680	160UHU33VB-T
A10C965	290-0946-00		CAP., FXD, ELCTLT:270UF, 10+100%, 40V	90201	VPR271N040E1E1C

Component No.	Tektronix Part No.	Serial/Model No. Eff Dscont	Name & Description	Mfr Code	Mfr Part Number
A10C971	290-0945-00		CAP., FXD, ELCLTLT:840UF, 10+100%, 12V	90201	VPR841N012E1E1C
A10C972	290-0945-00		CAP., FXD, ELCLTLT:840UF, 10+100%, 12V	90201	VPR841N012E1E1C
A10C975	290-0945-00		CAP., FXD, ELCLTLT:840UF, 10+100%, 12V	90201	VPR841N012E1E1C
A10C976	290-0945-00		CAP., FXD, ELCLTLT:840UF, 10+100%, 12V	90201	VPR841N012E1E1C
A10C977	281-0771-00		CAP., FXD, CER DI:0.0022UF, 20%, 200V	56289	292C Z5U222M200B
A10C985	290-0945-00		CAP., FXD, ELCLTLT:840UF, 10+100%, 12V	90201	VPR841N012E1E1C
A10C990	283-0430-00		CAP., FXD, CER DI:0.02UF, +80-20%, 3000V	000IQ	HV0309
A10C992	283-0430-00		CAP., FXD, CER DI:0.02UF, +80-20%, 3000V	000IQ	HV0309
A10C995	283-0430-00		CAP., FXD, CER DI:0.02UF, +80-20%, 3000V	000IQ	HV0309
A10CR177	152-0141-02		SEMICONV DEVICE: SILICON, 30V, 150MA	01295	1N4152R
A10CR178	152-0141-02		SEMICONV DEVICE: SILICON, 30V, 150MA	01295	1N4152R
A10CR187	152-0141-02		SEMICONV DEVICE: SILICON, 30V, 150MA	01295	1N4152R
A10CR188	152-0141-02		SEMICONV DEVICE: SILICON, 30V, 150MA	01295	1N4152R
A10CR196	152-0141-02		SEMICONV DEVICE: SILICON, 30V, 150MA	01295	1N4152R
A10CR277	152-0141-02		SEMICONV DEVICE: SILICON, 30V, 150MA	01295	1N4152R
A10CR278	152-0141-02		SEMICONV DEVICE: SILICON, 30V, 150MA	01295	1N4152R
A10CR287	152-0141-02		SEMICONV DEVICE: SILICON, 30V, 150MA	01295	1N4152R
A10CR288	152-0141-02		SEMICONV DEVICE: SILICON, 30V, 150MA	01295	1N4152R
A10CR296	152-0141-02		SEMICONV DEVICE: SILICON, 30V, 150MA	01295	1N4152R
A10CR305	152-0141-02		SEMICONV DEVICE: SILICON, 30V, 150MA	01295	1N4152R
A10CR320	152-0141-02		SEMICONV DEVICE: SILICON, 30V, 150MA	01295	1N4152R
A10CR409	152-0141-02		SEMICONV DEVICE: SILICON, 30V, 150MA	01295	1N4152R
A10CR418	152-0141-02		SEMICONV DEVICE: SILICON, 30V, 150MA	01295	1N4152R
A10CR440	152-0141-02		SEMICONV DEVICE: SILICON, 30V, 150MA	01295	1N4152R
A10CR444	152-0141-02		SEMICONV DEVICE: SILICON, 30V, 150MA	01295	1N4152R
A10CR448	152-0141-02		SEMICONV DEVICE: SILICON, 30V, 150MA	01295	1N4152R
A10CR503	152-0141-02		SEMICONV DEVICE: SILICON, 30V, 150MA	01295	1N4152R
A10CR504	152-0141-02		SEMICONV DEVICE: SILICON, 30V, 150MA	01295	1N4152R
A10CR610	152-0141-02		SEMICONV DEVICE: SILICON, 30V, 150MA	01295	1N4152R
A10CR611	152-0141-02		SEMICONV DEVICE: SILICON, 30V, 150MA	01295	1N4152R
A10CR615	152-0141-02		SEMICONV DEVICE: SILICON, 30V, 150MA	01295	1N4152R
A10CR620	152-0141-02		SEMICONV DEVICE: SILICON, 30V, 150MA	01295	1N4152R
A10CR622	152-0141-02		SEMICONV DEVICE: SILICON, 30V, 150MA	01295	1N4152R
A10CR640	152-0141-02		SEMICONV DEVICE: SILICON, 30V, 150MA	01295	1N4152R
A10CR644	152-0141-02		SEMICONV DEVICE: SILICON, 30V, 150MA	01295	1N4152R
A10CR704	152-0141-02		SEMICONV DEVICE: SILICON, 30V, 150MA	01295	1N4152R
A10CR745	152-0141-02		SEMICONV DEVICE: SILICON, 30V, 150MA	01295	1N4152R
A10CR748	152-0141-02		SEMICONV DEVICE: SILICON, 30V, 150MA	01295	1N4152R
A10CR749	152-0141-02		SEMICONV DEVICE: SILICON, 30V, 150MA	01295	1N4152R
A10CR770	152-0141-02		SEMICONV DEVICE: SILICON, 30V, 150MA	01295	1N4152R
A10CR772	152-0322-00		SEMICONV DEVICE: SILICON, 15V, HOT CARRIER	50434	5082-2672
A10CR773	152-0141-02		SEMICONV DEVICE: SILICON, 30V, 150MA	01295	1N4152R
A10CR780	152-0141-02		SEMICONV DEVICE: SILICON, 30V, 150MA	01295	1N4152R
A10CR782	152-0322-00		SEMICONV DEVICE: SILICON, 15V, HOT CARRIER	50434	5082-2672
A10CR783	152-0141-02		SEMICONV DEVICE: SILICON, 30V, 150MA	01295	1N4152R
A10CR801	152-0141-02		SEMICONV DEVICE: SILICON, 30V, 150MA	01295	1N4152R
A10CR802	152-0141-02		SEMICONV DEVICE: SILICON, 30V, 150MA	01295	1N4152R
A10CR809	152-0141-02		SEMICONV DEVICE: SILICON, 30V, 150MA	01295	1N4152R
A10CR828	152-0141-02		SEMICONV DEVICE: SILICON, 30V, 150MA	01295	1N4152R
A10CR830	152-0141-02		SEMICONV DEVICE: SILICON, 30V, 150MA	01295	1N4152R
A10CR833	152-0141-02		SEMICONV DEVICE: SILICON, 30V, 150MA	01295	1N4152R
A10CR834	152-0246-00		SEMICONV DEVICE: SW, SI, 40V, 200MA	03508	DE140
A10CR837	152-0141-02		SEMICONV DEVICE: SILICON, 30V, 150MA	01295	1N4152R
A10CR844	152-0141-02		SEMICONV DEVICE: SILICON, 30V, 150MA	01295	1N4152R
A10CR856	152-0242-00		SEMICONV DEVICE: SILICON, 225V, 200MA	07263	FDH5004
A10CR860	152-0242-00		SEMICONV DEVICE: SILICON, 225V, 200MA	07263	FDH5004
A10CR863	152-0242-00		SEMICONV DEVICE: SILICON, 225V, 200MA	07263	FDH5004

**Replaceable Electrical Parts—2215 Service**

Component No.	Tektronix Part No.	Serial/Model No. Eff	Dscont	Name & Description	Mfr Code	Mfr Part Number
A10CR867	152-0242-00			SEMICON DEVICE:SILICON,225V,200MA	07263	FDH5004
A10CR868	152-0242-00			SEMICON DEVICE:SILICON,225V,200MA	07263	FDH5004
A10CR903	152-0040-00			SEMICON DEVICE:SILICON,600V,1A	15238	LG109
A10CR904	152-0040-00			SEMICON DEVICE:SILICON,600V,1A	15238	LG109
A10CR905	152-0040-00			SEMICON DEVICE:SILICON,600V,1A	15238	LG109
A10CR906	152-0040-00			SEMICON DEVICE:SILICON,600V,1A	15238	LG109
A10CR917	152-0141-02			SEMICON DEVICE:SILICON,30V,150MA	01295	1N4152R
A10CR931	152-0782-00			SEMICON DEVICE:RECTIFIER,SILICON,600V	05828	GP20J-009
A10CR933	152-0782-00			SEMICON DEVICE:RECTIFIER,SILICON,600V	05828	GP20J-009
A10CR940	152-0414-00			SEMICON DEVICE:SILICON,200V,0.75A	12969	UTR308
A10CR942	152-0414-00			SEMICON DEVICE:SILICON,200V,0.75A	12969	UTR308
A10CR956	152-0141-02			SEMICON DEVICE:SILICON,30V,150MA	01295	1N4152R
A10CR961	152-0413-00			SEMICON DEVICE:SILICON,400V,750MA	12969	UTR307
A10CR963	152-0413-00			SEMICON DEVICE:SILICON,400V,750MA	12969	UTR307
A10CR965	152-0414-00			SEMICON DEVICE:SILICON,200V,0.75A	12969	UTR308
A10CR967	152-0414-00			SEMICON DEVICE:SILICON,200V,0.75A	12969	UTR308
A10CR971	152-0414-00			SEMICON DEVICE:SILICON,200V,0.75A	12969	UTR308
A10CR972	152-0414-00			SEMICON DEVICE:SILICON,200V,0.75A	12969	UTR308
A10CR973	152-0414-00			SEMICON DEVICE:SILICON,200V,0.75A	12969	UTR308
A10CR974	152-0414-00			SEMICON DEVICE:SILICON,200V,0.75A	12969	UTR308
A10CR977	152-0413-00			SEMICON DEVICE:SILICON,400V,750MA	12969	UTR307
A10CR985	152-0040-00			SEMICON DEVICE:SILICON,600V,1A	15238	LG109
A10DS854	150-0035-00			LAMP,GLOW:90V,0.3MA	53944	A1B-3
A10DS856	150-0035-00			LAMP,GLOW:90V,0.3MA	53944	A1B-3
A10DS867	150-0035-00			LAMP,GLOW:90V,0.3MA	53944	A1B-3
A10DS868	150-0035-00			LAMP,GLOW:90V,0.3MA	53944	A1B-3
A10DS870	150-0035-00			LAMP,GLOW:90V,0.3MA	53944	A1B-3
A10E199	276-0532-00			SHIELDING BEAD,:	02114	56-590-65/4A6
A10E299	276-0532-00			SHIELDING BEAD,:	02114	56-590-65/4A6
A10L971	108-1058-00			COIL,RF:FIXED,10UH	02113	B8724
A10L972	108-1058-00			COIL,RF:FIXED,10UH	02113	B8724
A10P1011	131-0608-00	B010100	B010417X	TERMINAL,PIN:0.365 L X 0.025 PH BRZ GOLD (QTY 4)	22526	47357
A10P2011	131-0608-00	B010100	B010417X	TERMINAL,PIN:0.365 L X 0.025 PH BRZ GOLD (QTY 4)	22526	47357
A10P6001	131-0608-00	B010100	B010417X	TERMINAL,PIN:0.365 L X 0.025 PH BRZ GOLD (QTY 10)	22526	47357
A10P7001	131-0608-00	B010100	B010417X	TERMINAL,PIN:0.365 L X 0.025 PH BRZ GOLD (QTY 7)	22526	47357
A10P7055	131-0608-00			TERMINAL,PIN:0.365 L X 0.025 PH BRZ GOLD (QTY 3)	22526	47357
A10P9000	131-1048-00			TERM.QIK DISC:CKT BD MT,0.11 X 0.02 (QTY 2)	00779	61134-1
A10P9025	131-1048-00			TERM.QIK DISC:CKT BD MT,0.11 X 0.02 (QTY 2)	00779	61134-1
A10Q157	151-0712-00			TRANSISTOR:SILICON,NPN	04713	SPS8223
A10Q167	151-0712-00			TRANSISTOR:SILICON,NPN	04713	SPS8223
A10Q173	151-0188-00			TRANSISTOR:SILICON,PNP	04713	SPS6868K
A10Q177	151-0712-00			TRANSISTOR:SILICON,NPN	04713	SPS8223
A10Q187	151-0712-00			TRANSISTOR:SILICON,NPN	04713	SPS8223
A10Q257	151-0712-00			TRANSISTOR:SILICON,NPN	04713	SPS8223
A10Q258	151-0712-00			TRANSISTOR:SILICON,NPN	04713	SPS8223
A10Q267	151-0712-00			TRANSISTOR:SILICON,NPN	04713	SPS8223
A10Q268	151-0712-00			TRANSISTOR:SILICON,NPN	04713	SPS8223
A10Q273	151-0188-00			TRANSISTOR:SILICON,PNP	04713	SPS6868K
A10Q277	151-0712-00			TRANSISTOR:SILICON,NPN	04713	SPS8223
A10Q287	151-0712-00			TRANSISTOR:SILICON,NPN	04713	SPS8223

Component No.	Tektronix Part No.	Serial/Model No. Eff Dscont	Name & Description	Mfr Code	Mfr Part Number
A10Q316	151-0188-00		TRANSISTOR:SILICON,PNP	04713	SPS6868K
A10Q331	151-0369-00		TRANSISTOR:SILICON,PNP	01295	SKA6664
A10Q335	151-0221-02		TRANSISTOR:SILICON,PNP	80009	151-0221-02
A10Q341	151-0369-00		TRANSISTOR:SILICON,PNP	01295	SKA6664
A10Q345	151-0221-02		TRANSISTOR:SILICON,PNP	80009	151-0221-02
A10Q350	151-0271-00		TRANSISTOR:SILICON,PNP	04713	SPS8236
A10Q360	151-0271-00		TRANSISTOR:SILICON,PNP	04713	SPS8236
A10Q370	151-0188-00		TRANSISTOR:SILICON,PNP	04713	SPS6868K
A10Q376	151-0752-00		TRANSISTOR:SILICON,NPN	01281	BFR96
A10Q377	151-0127-00		TRANSISTOR:SILICON,NPN	07263	S006075
A10Q380	151-0188-00		TRANSISTOR:SILICON,PNP	04713	SPS6868K
A10Q386	151-0752-00		TRANSISTOR:SILICON,NPN	01281	BFR96
A10Q387	151-0127-00		TRANSISTOR:SILICON,NPN	07263	S006075
A10Q392	151-0736-00		TRANSISTOR:SILICON,NPN	04713	SPS8317
A10Q411A,B	151-1042-00		SEMICON DVC SE:MATCHED PAIR FET	27014	SF50031
A10Q414	151-0198-00		TRANSISTOR:SILICON,NPN,SEL FROM MPS918	04713	SPS8802-1
A10Q474	151-0276-00		TRANSISTOR:SILICON,PNP	80009	151-0276-00
A10Q476	151-0276-00		TRANSISTOR:SILICON,PNP	80009	151-0276-00
A10Q492	151-0221-02		TRANSISTOR:SILICON,PNP	80009	151-0221-02
A10Q493	151-0221-02		TRANSISTOR:SILICON,PNP	80009	151-0221-02
A10Q503	151-0424-00		TRANSISTOR:SILICON,NPN	04713	SPS8246
A10Q504	151-0199-00		TRANSISTOR:SILICON,PNP	04713	SPS6866K
A10Q507	151-0424-00		TRANSISTOR:SILICON,NPN	04713	SPS8246
A10Q508	151-0199-00		TRANSISTOR:SILICON,PNP	04713	SPS6866K
A10Q519	151-0190-00		TRANSISTOR:SILICON,NPN	07263	S032677
A10Q605	151-0190-00		TRANSISTOR:SILICON,NPN	07263	S032677
A10Q640	151-0190-00		TRANSISTOR:SILICON,NPN	07263	S032677
A10Q703	151-0276-00		TRANSISTOR:SILICON,PNP	80009	151-0276-00
A10Q706	151-0276-00		TRANSISTOR:SILICON,PNP	80009	151-0276-00
A10Q708	151-0190-00		TRANSISTOR:SILICON,NPN	07263	S032677
A10Q714	151-1097-00		TRANSISTOR:SILICON,FE	04713	SPF713
A10Q747	151-0190-00		TRANSISTOR:SILICON,NPN	07263	S032677
A10Q753	151-0198-00		TRANSISTOR:SILICON,NPN,SEL FROM MPS918	04713	SPS8802-1
A10Q763	151-0198-00		TRANSISTOR:SILICON,NPN,SEL FROM MPS918	04713	SPS8802-1
A10Q765	151-0190-00		TRANSISTOR:SILICON,NPN	07263	S032677
A10Q770	151-0188-00		TRANSISTOR:SILICON,PNP	04713	SPS6868K
A10Q775	151-0347-00		TRANSISTOR:SILICON,NPN	56289	2N5551
A10Q779	151-0350-00		TRANSISTOR:SILICON,PNP	04713	SPS6700
A10Q780	151-0190-00		TRANSISTOR:SILICON,NPN	07263	S032677
A10Q785	151-0347-00		TRANSISTOR:SILICON,NPN	56289	2N5551
A10Q789	151-0350-00		TRANSISTOR:SILICON,PNP	04713	SPS6700
A10Q811	151-0188-00		TRANSISTOR:SILICON,PNP	04713	SPS6868K
A10Q812	151-0188-00		TRANSISTOR:SILICON,PNP	04713	SPS6868K
A10Q813	151-0188-00		TRANSISTOR:SILICON,PNP	04713	SPS6868K
A10Q841	151-0190-00		TRANSISTOR:SILICON,NPN	07263	S032677
A10Q844	151-0188-00		TRANSISTOR:SILICON,PNP	04713	SPS6868K
A10Q845	151-0188-00		TRANSISTOR:SILICON,PNP	04713	SPS6868K
A10Q847	151-0347-00		TRANSISTOR:SILICON,NPN	56289	2N5551
A10Q850	151-0350-00		TRANSISTOR:SILICON,PNP	04713	SPS6700
A10Q877	151-0443-00		TRANSISTOR:SILICON,PNP	80009	151-0443-00
A10Q918	151-0432-00		TRANSISTOR:SILICON,NPN	80009	151-0432-00
A10Q921	151-0508-00		TRANSISTOR:UJT,SI,2N6027,T0-98	03508	2N6027
A10Q925	151-0538-00		THYRISTOR:TRIAC,SI,600V,8.0A,T0-220	02735	0BD
A10Q940	151-0476-02		TRANSISTOR:SILICON,NPN,SFI	04713	0BD
A10Q942	151-0476-02		TRANSISTOR:SILICON,NPN,SEL	04713	0BD
A10Q948	151-0453-00		TRANSISTOR:SILICON,PNP	80009	151-0453-00
A10Q954	151-0453-00		TRANSISTOR:SILICON,PNP	80009	151-0453-00

Replaceable Electrical Parts—2215 Service

Component No.	Tektronix Part No.	Serial/Model No. Eff Dscont	Name & Description	Mfr Code	Mfr Part Number
A10Q956	151-0432-00		TRANSISTOR:SILICON,NPN	80009	151-0432-00
A10R151	315-0360-00		RES.,FXD,CMPSN:36 OHM,5%,0.25W	01121	CB3605
A10R152	321-0187-00		RES.,FXD,FILM:866 OHM,1%,0.125W	91637	MFF1816G866R0F
A10R153	321-0225-00		RES.,FXD,FILM:2.15K OHM,1%,0.125W	91637	MFF1816G21500F
A10R154	311-1568-00		RES.,VAR,NONWIR:50 OHM,20%,0.50W	73138	91-90-0
A10R158	321-0126-00		RES.,FXD,FILM:200 OHM,1%,0.125W	91637	MFF1816G200R0F
A10R159	321-0199-00		RES.,FXD,FILM:1.15K OHM,1%,0.125W	91637	MFF1816G11500F
A10R161	315-0360-00		RES.,FXD,CMPSN:36 OHM,5%,0.25W	01121	CB3605
A10R162	321-0187-00		RES.,FXD,FILM:866 OHM,1%,0.125W	91637	MFF1816G866R0F
A10R163	321-0224-00		RES.,FXD,FILM:2.1K OHM,1%,0.125W	91637	MFF1816G21000F
A10R168	321-0126-00		RES.,FXD,FILM:200 OHM,1%,0.125W	91637	MFF1816G200R0F
A10R169	321-0199-00		RES.,FXD,FILM:1.15K OHM,1%,0.125W	91637	MFF1816G11500F
A10R170	321-0203-00		RES.,FXD,FILM:1.27K OHM,1%,0.125W	91637	MFF1816G12700F
A10R172	321-0083-00		RES.,FXD,FILM:71.5 OHM,1%,0.125W	91637	MFF1816G71R50F
A10R173	315-0102-00		RES.,FXD,CMPSN:1K OHM,5%,0.25W	01121	CB1025
A10R174	315-0111-00		RES.,FXD,CMPSN:110 OHM,5%,0.25W	01121	CB1115
A10R175	315-0102-00		RES.,FXD,CMPSN:1K OHM,5%,0.25W	01121	CB1025
A10R176	315-0391-00		RES.,FXD,CMPSN:390 OHM,5%,0.25W	01121	CB3915
A10R177	321-0091-00		RES.,FXD,FILM:86.6 OHM,1%,0.125W	91637	MFF1816G86R60F
A10R178	321-0162-00		RES.,FXD,FILM:475 OHM,1%,0.125W	91637	MFF1816G475R0F
A10R179	315-0621-00		RES.,FXD,CMPSN:620 OHM,5%,0.25W	01121	CB6215
A10R180	321-0088-00		RES.,FXD,FILM:80.6 OHM,1%,0.125W	91637	MFF1816G80R60F
A10R182	321-0083-00		RES.,FXD,FILM:71.5 OHM,1%,0.125W	91637	MFF1816G71R50F
A10R183	315-0201-00		RES.,FXD,CMPSN:200 OHM,5%,0.25W	01121	CB2015
A10R185	315-0102-00		RES.,FXD,CMPSN:1K OHM,5%,0.25W	01121	CB1025
A10R186	311-1238-00		RES.,VAR,NONWIR:5K OHM,10%,0.50W	73138	72-27-0
A10R187	321-0091-00		RES.,FXD,FILM:86.6 OHM,1%,0.125W	91637	MFF1816G86R60F
A10R188	321-0162-00		RES.,FXD,FILM:475 OHM,1%,0.125W	91637	MFF1816G475R0F
A10R189	315-0621-00		RES.,FXD,CMPSN:620 OHM,5%,0.25W	01121	CB6215
A10R192	321-0231-00		RES.,FXD,FILM:2.49K OHM,1%,0.125W	91637	MFF1816G24900F
A10R193	321-0230-00		RES.,FXD,FILM:2.43K OHM,1%,0.125W	91637	MFF1816G24300F
A10R194	315-0470-00		RES.,FXD,CMPSN:47 OHM,5%,0.25W	01121	CB4705
A10R196	315-0681-00		RES.,FXD,CMPSN:680 OHM,5%,0.25W	01121	CB6815
A10R197	315-0561-00		RES.,FXD,CMPSN:560 OHM,5%,0.25W	01121	CB5615
A10R250	315-0911-00		RES.,FXD,CMPSN:910 OHM,5%,0.25W	01121	CB9115
A10R251	315-0360-00		RES.,FXD,CMPSN:36 OHM,5%,0.25W	01121	CB3605
A10R252	321-0188-00		RES.,FXD,FILM:887 OHM,1%,0.125W	91637	MFF1816G887R0F
A10R253	321-0203-00		RES.,FXD,FILM:1.27K OHM,1%,0.125W	91637	MFF1816G12700F
A10R254	315-0821-00		RES.,FXD,CMPSN:820 OHM,5%,0.25W	01121	CB8215
A10R256	321-0253-00		RES.,FXD,FILM:4.22K OHM,1%,0.125W	91637	MFF1816G42200F
A10R258	321-0126-00		RES.,FXD,FILM:200 OHM,1%,0.125W	91637	MFF1816G200R0F
A10R259	321-0199-00		RES.,FXD,FILM:1.15K OHM,1%,0.125W	91637	MFF1816G11500F
A10R261	315-0360-00		RES.,FXD,CMPSN:36 OHM,5%,0.25W	01121	CB3605
A10R262	321-0188-00		RES.,FXD,FILM:887 OHM,1%,0.125W	91637	MFF1816G887R0F
A10R263	321-0225-00		RES.,FXD,FILM:2.15K OHM,1%,0.125W	91637	MFF1816G21500F
A10R264	311-1567-00		RES.,VAR,NONWIR:TRMR,100 OHM,0.50W	73138	91-89-0
A10R266	321-0253-00		RES.,FXD,FILM:4.22K OHM,1%,0.125W	91637	MFF1816G42200F
A10R268	321-0126-00		RES.,FXD,FILM:200 OHM,1%,0.125W	91637	MFF1816G200R0F
A10R269	321-0199-00		RES.,FXD,FILM:1.15K OHM,1%,0.125W	91637	MFF1816G11500F
A10R270	321-0203-00		RES.,FXD,FILM:1.27K OHM,1%,0.125W	91637	MFF1816G12700F
A10R272	321-0083-00		RES.,FXD,FILM:71.5 OHM,1%,0.125W	91637	MFF1816G71R50F
A10R273	315-0102-00		RES.,FXD,CMPSN:1K OHM,5%,0.25W	01121	CB1025
A10R275	315-0102-00		RES.,FXD,CMPSN:1K OHM,5%,0.25W	01121	CB1025
A10R276	315-0391-00		RES.,FXD,CMPSN:390 OHM,5%,0.25W	01121	CB3915
A10R277	321-0091-00		RES.,FXD,FILM:86.6 OHM,1%,0.125W	91637	MFF1816G86R60F
A10R278	321-0162-00		RES.,FXD,FILM:475 OHM,1%,0.125W	91637	MFF1816G475R0F
A10R279	315-0621-00		RES.,FXD,CMPSN:620 OHM,5%,0.25W	01121	CB6215



Component No.	Tektronix Part No.	Serial/Model No. Eff Dscont	Name & Description	Mfr Code	Mfr Part Number
A10R280	321-0088-00		RES., FXD, FILM:80.6 OHM, 1%, 0.125W	91637	MFF1816G80R60F
A10R282	321-0083-00		RES., FXD, FILM:71.5 OHM, 1%, 0.125W	91637	MFF1816G71R50F
A10R283	315-0201-00		RES., FXD, CMPSN:200 OHM, 5%, 0.25W	01121	CB2015
A10R284	315-0111-00		RES., FXD, CMPSN:110 OHM, 5%, 0.25W	01121	CB1115
A10R285	315-0102-00		RES., FXD, CMPSN:1K OHM, 5%, 0.25W	01121	CB1025
A10R286	311-1238-00		RES., VAR, NONWIR:5K OHM, 10%, 0.50W	73138	72-27-0
A10R287	321-0091-00		RES., FXD, FILM:86.6 OHM, 1%, 0.125W	91637	MFF1816G86R60F
A10R288	321-0162-00		RES., FXD, FILM:475 OHM, 1%, 0.125W	91637	MFF1816G475R0F
A10R289	315-0621-00		RES., FXD, CMPSN:620 OHM, 5%, 0.25W	01121	CB6215
A10R292	321-0231-00		RES., FXD, FILM:2.49K OHM, 1%, 0.125W	91637	MFF1816G24900F
A10R293	321-0230-00		RES., FXD, FILM:2.43K OHM, 1%, 0.125W	91637	MFF1816G24300F
A10R294	315-0470-00		RES., FXD, CMPSN:47 OHM, 5%, 0.25W	01121	CB4705
A10R295	315-0102-00		RES., FXD, CMPSN:1K OHM, 5%, 0.25W	01121	CB1025
A10R296	315-0681-00		RES., FXD, CMPSN:680 OHM, 5%, 0.25W	01121	CB6815
A10R297	315-0102-00		RES., FXD, CMPSN:1K OHM, 5%, 0.25W	01121	CB1025
A10R299	315-0912-00		RES., FXD, CMPSN:9.1K OHM, 5%, 0.25W	01121	CB9125
A10R300	315-0512-00		RES., FXD, CMPSN:5.1K OHM, 5%, 0.25W	01121	CB5125
A10R301	315-0512-00		RES., FXD, CMPSN:5.1K OHM, 5%, 0.25W	01121	CB5125
A10R302	315-0512-00		RES., FXD, CMPSN:5.1K OHM, 5%, 0.25W	01121	CB5125
A10R304	315-0512-00		RES., FXD, CMPSN:5.1K OHM, 5%, 0.25W	01121	CB5125
A10R305	315-0512-00		RES., FXD, CMPSN:5.1K OHM, 5%, 0.25W	01121	CB5125
A10R306	315-0512-00		RES., FXD, CMPSN:5.1K OHM, 5%, 0.25W	01121	CB5125
A10R307	315-0361-00		RES., FXD, CMPSN:360 OHM, 5%, 0.25W	01121	CB3615
A10R308	315-0911-00		RES., FXD, CMPSN:910 OHM, 5%, 0.25W	01121	CB9115
A10R310	315-0102-00		RES., FXD, CMPSN:1K OHM, 5%, 0.25W	01121	CB1025
A10R311	315-0102-00		RES., FXD, CMPSN:1K OHM, 5%, 0.25W	01121	CB1025
A10R312	315-0511-00	B010100 B010684X	RES., FXD, CMPSN:510 OHM, 5%, 0.25W	01121	CB5115
A10R313	315-0511-00	B010100 B010684X	RES., FXD, CMPSN:510 OHM, 5%, 0.25W	01121	CB5115
A10R315	315-0103-00		RES., FXD, CMPSN:10K OHM, 5%, 0.25W	01121	CB1035
A10R316	315-0512-00		RES., FXD, CMPSN:5.1K OHM, 5%, 0.25W	01121	CB5125
A10R317	315-0101-00		RES., FXD, CMPSN:100 OHM, 5%, 0.25W	01121	CB1015
A10R318	315-0101-00		RES., FXD, CMPSN:100 OHM, 5%, 0.25W	01121	CB1015
A10R319	315-0512-00		RES., FXD, CMPSN:5.1K OHM, 5%, 0.25W	01121	CB5125
A10R320	315-0102-00		RES., FXD, CMPSN:1K OHM, 5%, 0.25W	01121	CB1025
A10R321	315-0512-00		RES., FXD, CMPSN:5.1K OHM, 5%, 0.25W	01121	CB5125
A10R322	315-0201-00		RES., FXD, CMPSN:200 OHM, 5%, 0.25W	01121	CB2015
A10R323	315-0103-00		RES., FXD, CMPSN:10K OHM, 5%, 0.25W	01121	CB1035
A10R324	321-0253-00		RES., FXD, FILM:4.22K OHM, 1%, 0.125W	91637	MFF1816G42200F
A10R325	321-0253-00		RES., FXD, FILM:4.22K OHM, 1%, 0.125W	91637	MFF1816G42200F
A10R326	315-0362-00		RES., FXD, CMPSN:3.6K OHM, 5%, 0.25W	01121	CB3625
A10R327	315-0362-00		RES., FXD, CMPSN:3.6K OHM, 5%, 0.25W	01121	CB3625
A10R330	321-0140-00		RES., FXD, FILM:280 OHM, 1%, 0.125W	91637	MFF1816G280R0F
A10R331	321-0152-00		RES., FXD, FILM:374 OHM, 1%, 0.125W	91637	MFF1816G374R0F
A10R332	315-0101-00		RES., FXD, CMPSN:100 OHM, 5%, 0.25W	01121	CB1015
A10R334	321-0189-00		RES., FXD, FILM:909 OHM, 1%, 0.125W	91637	MFF1816G909R0F
A10R335	321-0084-00		RES., FXD, FILM:73.2 OHM, 1%, 0.125W	91637	MFF1816G73R20F
A10R336	321-0183-00		RES., FXD, FILM:787 OHM, 1%, 0.125W	91637	MFF1816G787R0F
A10R338	321-0087-00		RES., FXD, FILM:78.7 OHM, 1%, 0.125W	91637	MFF1816G78R70F
A10R340	315-0201-00		RES., FXD, CMPSN:200 OHM, 5%, 0.25W	01121	CB2015
A10R341	321-0152-00		RES., FXD, FILM:374 OHM, 1%, 0.125W	91637	MFF1816G374R0F
A10R342	321-0127-00		RES., FXD, FILM:205 OHM, 1%, 0.125W	91637	MFF1816G205R0F
A10R344	321-0189-00		RES., FXD, FILM:909 OHM, 1%, 0.125W	91637	MFF1816G909R0F
A10R345	321-0084-00		RES., FXD, FILM:73.2 OHM, 1%, 0.125W	91637	MFF1816G73R20F
A10R346	321-0183-00		RES., FXD, FILM:787 OHM, 1%, 0.125W	91637	MFF1816G787R0F
A10R348	321-0087-00		RES., FXD, FILM:78.7 OHM, 1%, 0.125W	91637	MFF1816G78R70F
A10R350	315-0221-00		RES., FXD, CMPSN:220 OHM, 5%, 0.25W	01121	CB2215
A10R351	321-0130-00		RES., FXD, FILM:221 OHM, 1%, 0.125W	91637	MFF1816G221R0F

# Replaceable Electrical Parts—2215 Service

Component No.	Tektronix Part No.	Serial/Model No. Eff Dscont	Name & Description	Mfr Code	Mfr Part Number
A10R353	315-0390-00		RES., FXD, CMPSN: 39 OHM, 5%, 0.25W	01121	CB3905
A10R354	321-0180-00		RES., FXD, FILM: 732 OHM, 1%, 0.125W	91637	MFF1816G732R0F
A10R355	321-0080-00		RES., FXD, FILM: 66.5 OHM, 1%, 0.125W	91637	MFF1816G66R50F
A10R356	315-0621-00		RES., FXD, CMPSN: 620 OHM, 5%, 0.25W	01121	CB6215
A10R357	311-1936-00		RES., VAR, NONWIR: CKT BD, 50 OHM, 20%, 0.5W	73138	MODEL 72X
A10R358	315-0112-00		RES., FXD, CMPSN: 1.1K OHM, 5%, 0.25W	01121	CB1125
A10R360	315-0221-00		RES., FXD, CMPSN: 220 OHM, 5%, 0.25W	01121	CB2215
A10R361	321-0130-00		RES., FXD, FILM: 221 OHM, 1%, 0.125W	91637	MFF1816G221R0F
A10R363	315-0390-00		RES., FXD, CMPSN: 39 OHM, 5%, 0.25W	01121	CB3905
A10R364	321-0180-00		RES., FXD, FILM: 732 OHM, 1%, 0.125W	91637	MFF1816G732R0F
A10R366	311-1236-00		RES., VAR, NONWIR: 250 OHM, 10%, 0.50W	73138	72-22-0
A10R367	311-1237-00		RES., VAR, NONWIR: 1K OHM, 10%, 0.50W	32997	3386X-T07-102
A10R368	315-0912-00		RES., FXD, CMPSN: 9.1K OHM, 5%, 0.25W	01121	CB9125
A10R370	315-0471-00		RES., FXD, CMPSN: 470 OHM, 5%, 0.25W	01121	CB4715
A10R371	315-0561-00		RES., FXD, CMPSN: 560 OHM, 5%, 0.25W	01121	CB5615
A10R373	321-0068-00		RES., FXD, FILM: 49.9 OHM, 1%, 0.125W	91637	MFF1816G49R90F
A10R374	315-0101-00		RES., FXD, CMPSN: 100 OHM, 5%, 0.25W	01121	CB1015
A10R376	321-0196-00		RES., FXD, FILM: 1.07K OHM, 1%, 0.125W	91637	MFF1816G10700F
A10R377	321-0190-00		RES., FXD, FILM: 931 OHM, 1%, 0.125W	91637	MFF1816G931R0F
A10R378	323-0148-00		RES., FXD, FILM: 340 OHM, 1%, 0.50W	91637	MFF1226G340R0F
A10R379	323-0148-00		RES., FXD, FILM: 340 OHM, 1%, 0.50W	91637	MFF1226G340R0F
A10R380	315-0471-00		RES., FXD, CMPSN: 470 OHM, 5%, 0.25W	01121	CB4715
A10R383	321-0068-00		RES., FXD, FILM: 49.9 OHM, 1%, 0.125W	91637	MFF1816G49R90F
A10R384	321-0198-00		RES., FXD, FILM: 1.13K OHM, 1%, 0.125W	91637	MFF1816G11300F
A10R386	321-0196-00		RES., FXD, FILM: 1.07K OHM, 1%, 0.125W	91637	MFF1816G10700F
A10R387	321-0190-00		RES., FXD, FILM: 931 OHM, 1%, 0.125W	91637	MFF1816G931R0F
A10R388	323-0148-00		RES., FXD, FILM: 340 OHM, 1%, 0.50W	91637	MFF1226G340R0F
A10R389	323-0148-00		RES., FXD, FILM: 340 OHM, 1%, 0.50W	91637	MFF1226G340R0F
A10R390	322-0084-00		RES., FXD, FILM: 73.2 OHM, 1%, 0.25W	91637	CMF1842G73R20F
A10R391	315-0271-00		RES., FXD, CMPSN: 270 OHM, 5%, 0.25W	01121	CB2715
A10R392	315-0752-00		RES., FXD, CMPSN: 7.5K OHM, 5%, 0.25W	01121	CB7525
A10R393	315-0621-00		RES., FXD, CMPSN: 620 OHM, 5%, 0.25W	01121	CB6215
A10R394	315-0821-00		RES., FXD, CMPSN: 820 OHM, 5%, 0.25W	01121	CB8215
A10R397	315-0681-00		RES., FXD, CMPSN: 680 OHM, 5%, 0.25W	01121	CB6815
A10R398	301-0510-00		RES., FXD, CMPSN: 51 OHM, 5%, 0.50W	01121	EB5105
A10R399	301-0510-00		RES., FXD, CMPSN: 51 OHM, 5%, 0.50W	01121	EB5105
A10R408	321-0427-00		RES., FXD, FILM: 274K OHM, 1%, 0.125W	24546	NA55D2743F
A10R410	315-0101-00		RES., FXD, CMPSN: 100 OHM, 5%, 0.25W	01121	CB1015
A10R411	315-0121-00		RES., FXD, CMPSN: 120 OHM, 5%, 0.25W	01121	CB1215
A10R412	315-0100-00		RES., FXD, CMPSN: 10 OHM, 5%, 0.25W	01121	CB1005
A10R414	315-0270-00		RES., FXD, CMPSN: 27 OHM, 5%, 0.25W	01121	CB2705
A10R415	315-0911-00		RES., FXD, CMPSN: 910 OHM, 5%, 0.25W	01121	CB9115
A10R417	315-0751-00		RES., FXD, CMPSN: 750 OHM, 5%, 0.25W	01121	CB7515
A10R418	315-0360-00		RES., FXD, CMPSN: 36 OHM, 5%, 0.25W	01121	CB3605
A10R421	315-0430-00		RES., FXD, CMPSN: 43 OHM, 5%, 0.25W	01121	CB4305
A10R422	315-0430-00		RES., FXD, CMPSN: 43 OHM, 5%, 0.25W	01121	CB4305
A10R423	315-0511-00		RES., FXD, CMPSN: 510 OHM, 5%, 0.25W	01121	CB5115
A10R424	315-0392-00		RES., FXD, CMPSN: 3.9K OHM, 5%, 0.25W	01121	CB3925
A10R426	315-0101-00		RES., FXD, CMPSN: 100 OHM, 5%, 0.25W	01121	CB1015
A10R427	321-0158-00		RES., FXD, FILM: 432 OHM, 1%, 0.125W	91637	MFF1816G432R0F
A10R428	321-0159-00		RES., FXD, FILM: 442 OHM, 1%, 0.125W	91637	MFF1816G442R0F
A10R429	315-0471-00		RES., FXD, CMPSN: 470 OHM, 5%, 0.25W	01121	CB4715
A10R430	315-0822-00		RES., FXD, CMPSN: 8.2K OHM, 5%, 0.25W	01121	CB8225
A10R431	307-0107-00		RES., FXD, CMPSN: 5.6 OHM, 5%, 0.25W	01121	CB56G5
A10R432	307-0107-00		RES., FXD, CMPSN: 5.6 OHM, 5%, 0.25W	01121	CB56G5
A10R433	315-0331-00		RES., FXD, CMPSN: 330 OHM, 5%, 0.25W	01121	CB3315
A10R435	315-0202-00		RES., FXD, CMPSN: 2K OHM, 5%, 0.25W	01121	CB2025

Component No.	Tektronix Part No.	Serial/Model No. Eff Dscont	Name & Description	Mfr Code	Mfr Part Number
A10R436	315-0620-00		RES.,FXD,CMPSN:62 OHM,5%,0.25W	01121	CB6205
A10R437	315-0911-00		RES.,FXD,CMPSN:910 OHM,5%,0.25W	01121	CB9115
A10R438	315-0751-00		RES.,FXD,CMPSN:750 OHM,5%,0.25W	01121	CB7515
A10R440	315-0220-00		RES.,FXD,CMPSN:22 OHM,5%,0.25W	01121	CB2205
A10R442	315-0202-00		RES.,FXD,CMPSN:2K OHM,5%,0.25W	01121	CB2025
A10R444	315-0750-00		RES.,FXD,CMPSN:75 OHM,5%,0.25W	01121	CB7505
A10R445	315-0911-00		RES.,FXD,CMPSN:910 OHM,5%,0.25W	01121	CB9115
A10R446	315-0751-00		RES.,FXD,CMPSN:750 OHM,5%,0.25W	01121	CB7515
A10R447	301-0433-00		RES.,FXD,CMPSN:43K OHM,5%,0.50W	01121	EB4335
A10R448	315-0473-00		RES.,FXD,CMPSN:47K OHM,5%,0.25W	01121	CB4735
A10R450	301-0433-00		RES.,FXD,CMPSN:43K OHM,5%,0.50W	01121	EB4335
A10R453	315-0510-00		RES.,FXD,CMPSN:51 OHM,5%,0.25W	01121	CB5105
A10R454	315-0514-00		RES.,FXD,CMPSN:510K OHM,5%,0.25W	01121	CB5145
A10R456	315-0302-00		RES.,FXD,CMPSN:3K OHM,5%,0.25W	01121	CB3025
A10R457	315-0100-00		RES.,FXD,CMPSN:10 OHM,5%,0.25W	01121	CB1005
A10R458	315-0100-00		RES.,FXD,CMPSN:10 OHM,5%,0.25W	01121	CB1005
A10R459	315-0103-00		RES.,FXD,CMPSN:10K OHM,5%,0.25W	01121	CB1035
A10R460	321-0207-00		RES.,FXD,FILM:1.4K OHM,1%,0.125W	91637	MFF1816G14000F
A10R461	321-0197-00		RES.,FXD,FILM:1.1K OHM,1%,0.125W	91637	MFF1816G11000F
A10R462	321-0203-00		RES.,FXD,FILM:1.27K OHM,1%,0.125W	91637	MFF1816G12700F
A10R463	321-0201-00		RES.,FXD,FILM:1.21K OHM,1%,0.125W	91637	MFF1816G12100F
A10R464	315-0242-00		RES.,FXD,CMPSN:2.4K OHM,5%,0.25W	01121	CB2425
A10R466	315-0101-00		RES.,FXD,CMPSN:100 OHM,5%,0.25W	01121	CB1015
A10R467	315-0681-00		RES.,FXD,CMPSN:680 OHM,5%,0.25W	01121	CB6815
A10R468	315-0820-00		RES.,FXD,CMPSN:82 OHM,5%,0.25W	01121	CB8205
A10R469	315-0113-00		RES.,FXD,CMPSN:11K OHM,5%,0.25W	01121	CB1135
A10R470	315-0201-00		RES.,FXD,CMPSN:200 OHM,5%,0.25W	01121	CB2015
A10R471	315-0432-00		RES.,FXD,CMPSN:4.3K OHM,5%,0.25W	01121	CB4325
A10R472	315-0221-00		RES.,FXD,CMPSN:220 OHM,5%,0.25W	01121	CB2215
A10R473	315-0562-00		RES.,FXD,CMPSN:5.6K OHM,5%,0.25W	01121	CB5625
A10R474	315-0182-00		RES.,FXD,CMPSN:1.8K OHM,5%,0.25W	01121	CB1825
A10R476	315-0392-00		RES.,FXD,CMPSN:3.9K OHM,5%,0.25W	01121	CB3925
A10R477	315-0392-00		RES.,FXD,CMPSN:3.9K OHM,5%,0.25W	01121	CB3925
A10R478	315-0392-00		RES.,FXD,CMPSN:3.9K OHM,5%,0.25W	01121	CB3925
A10R479	315-0752-00		RES.,FXD,CMPSN:7.5K OHM,5%,0.25W	01121	CB7525
A10R480	315-0822-00		RES.,FXD,CMPSN:8.2K OHM,5%,0.25W	01121	CB8225
A10R481	321-0191-00		RES.,FXD,FILM:953 OHM,1%,0.125W	91637	MFF1816G953R0F
A10R482	311-1238-00		RES.,VAR, NONWIR:5K OHM,10%,0.50W	73138	72-27-0
A10R483	315-0392-00		RES.,FXD,CMPSN:3.9K OHM,5%,0.25W	01121	CB3925
A10R484	315-0431-00		RES.,FXD,CMPSN:430 OHM,5%,0.25W	01121	CB4315
A10R485	315-0431-00		RES.,FXD,CMPSN:430 OHM,5%,0.25W	01121	CB4315
A10R487	301-0360-00		RES.,FXD,CMPSN:36 OHM,5%,0.5W	01121	EB3605
A10R490	315-0241-00		RES.,FXD,CMPSN:240 OHM,5%,0.25W	01121	CB2415
A10R491	315-0201-00		RES.,FXD,CMPSN:200 OHM,5%,0.25W	01121	CB2015
A10R492	315-0822-00		RES.,FXD,CMPSN:8.2K OHM,5%,0.25W	01121	CB8225
A10R493	315-0822-00		RES.,FXD,CMPSN:8.2K OHM,5%,0.25W	01121	CB8225
A10R494	315-0151-00		RES.,FXD,CMPSN:150 OHM,5%,0.25W	01121	CB1515
A10R495	315-0151-00		RES.,FXD,CMPSN:150 OHM,5%,0.25W	01121	CB1515
A10R496	315-0124-00		RES.,FXD,CMPSN:120K OHM,5%,0.25W	01121	CB1245
A10R497	315-0241-00		RES.,FXD,CMPSN:240 OHM,5%,0.25W	01121	CB2415
A10R501	315-0101-00		RES.,FXD,CMPSN:100 OHM,5%,0.25W	01121	CB1015
A10R503	315-0100-00		RES.,FXD,CMPSN:10 OHM,5%,0.25W	01121	CB1005
A10R504	315-0100-00		RES.,FXD,CMPSN:10 OHM,5%,0.25W	01121	CB1005
A10R505	315-0434-00		RES.,FXD,CMPSN:430K OHM,5%,0.25W	01121	CB4345
A10R506	315-0434-00		RES.,FXD,CMPSN:430K OHM,5%,0.25W	01121	CB4345
A10R507	315-0823-00		RES.,FXD,CMPSN:82K OHM,5%,0.25W	01121	CB8235
A10R508	315-0823-00		RES.,FXD,CMPSN:82K OHM,5%,0.25W	01121	CB8235

# Replaceable Electrical Parts—2215 Service

Component No.	Tektronix Part No.	Serial/Model No. Eff Dscont	Name & Description	Mfr Code	Mfr Part Number
A10R511	311-1646-00		RES., VAR, NONWIR: TRMR, 2M OHM, 0.5W	01121	E4A205
A10R512	311-1646-00		RES., VAR, NONWIR: TRMR, 2M OHM, 0.5W	01121	E4A205
A10R513	315-0102-00		RES., FXD, CMPSN: 1K OHM, 5%, 0.25W	01121	CB1025
A10R514	315-0102-00		RES., FXD, CMPSN: 1K OHM, 5%, 0.25W	01121	CB1025
A10R517	315-0103-00		RES., FXD, CMPSN: 10K OHM, 5%, 0.25W	01121	CB1035
A10R518	315-0102-00		RES., FXD, CMPSN: 1K OHM, 5%, 0.25W	01121	CB1025
A10R519	315-0113-00		RES., FXD, CMPSN: 11K OHM, 5%, 0.25W	01121	CB1135
A10R525	315-0274-00		RES., FXD, CMPSN: 270K OHM, 5%, 0.25W	01121	CB2745
A10R526	315-0274-00		RES., FXD, CMPSN: 270K OHM, 5%, 0.25W	01121	CB2745
A10R527	315-0473-00		RES., FXD, CMPSN: 47K OHM, 5%, 0.25W	01121	CB4735
A10R528	315-0473-00		RES., FXD, CMPSN: 47K OHM, 5%, 0.25W	01121	CB4735
A10R603	315-0512-00		RES., FXD, CMPSN: 5.1K OHM, 5%, 0.25W	01121	CB5125
A10R605	315-0512-00		RES., FXD, CMPSN: 5.1K OHM, 5%, 0.25W	01121	CB5125
A10R607	315-0512-00		RES., FXD, CMPSN: 5.1K OHM, 5%, 0.25W	01121	CB5125
A10R608	315-0512-00		RES., FXD, CMPSN: 5.1K OHM, 5%, 0.25W	01121	CB5125
A10R610	315-0512-00		RES., FXD, CMPSN: 5.1K OHM, 5%, 0.25W	01121	CB5125
A10R611	315-0682-00		RES., FXD, CMPSN: 6.8K OHM, 5%, 0.25W	01121	CB6825
A10R612	315-0163-00		RES., FXD, CMPSN: 16K OHM, 5%, 0.25W	01121	CB1635
A10R614	315-0203-00		RES., FXD, CMPSN: 20K OHM, 5%, 0.25W	01121	CB2035
A10R615	315-0621-00		RES., FXD, CMPSN: 620 OHM, 5%, 0.25W	01121	CB6215
A10R618	315-0221-00		RES., FXD, CMPSN: 220 OHM, 5%, 0.25W	01121	CB2215
A10R619	315-0621-00		RES., FXD, CMPSN: 620 OHM, 5%, 0.25W	01121	CB6215
A10R620	315-0102-00		RES., FXD, CMPSN: 1K OHM, 5%, 0.25W	01121	CB1025
A10R622	315-0302-00		RES., FXD, CMPSN: 3K OHM, 5%, 0.25W	01121	CB3025
A10R623	315-0681-00		RES., FXD, CMPSN: 680 OHM, 5%, 0.25W	01121	CB6815
A10R637	321-0322-00		RES., FXD, FILM: 22.1K OHM, 1%, 0.125W	91637	MFF1816G22101F
A10R638	321-0319-00		RES., FXD, FILM: 20.5K OHM, 1%, 0.125W	91637	MFF1816G20501F
A10R639	315-0153-00		RES., FXD, CMPSN: 15K OHM, 5%, 0.25W	01121	CB1535
A10R640	315-0512-00		RES., FXD, CMPSN: 5.1K OHM, 5%, 0.25W	01121	CB5125
A10R642	315-0222-00		RES., FXD, CMPSN: 2.2K OHM, 5%, 0.25W	01121	CB2225
A10R649	315-0512-00		RES., FXD, CMPSN: 5.1K OHM, 5%, 0.25W	01121	CB5125
A10R651	315-0201-00		RES., FXD, CMPSN: 200 OHM, 5%, 0.25W	01121	CB2015
A10R666	315-0820-00		RES., FXD, CMPSN: 82 OHM, 5%, 0.25W	01121	CB8205
A10R668	315-0820-00		RES., FXD, CMPSN: 82 OHM, 5%, 0.25W	01121	CB8205
A10R670	315-0100-00		RES., FXD, CMPSN: 10 OHM, 5%, 0.25W	01121	CB1005
A10R673	315-0681-00		RES., FXD, CMPSN: 680 OHM, 5%, 0.25W	01121	CB6815
A10R674	315-0621-00		RES., FXD, CMPSN: 620 OHM, 5%, 0.25W	01121	CB6215
A10R701	321-0235-00		RES., FXD, FILM: 2.74K OHM, 1%, 0.125W	91637	MFF1816G27400F
A10R702	315-0392-00		RES., FXD, CMPSN: 3.9K OHM, 5%, 0.25W	01121	CB3925
A10R703	315-0154-00		RES., FXD, CMPSN: 150K OHM, 5%, 0.25W	01121	CB1545
A10R704	315-0621-00		RES., FXD, CMPSN: 620 OHM, 5%, 0.25W	01121	CB6215
A10R705	315-0752-00		RES., FXD, CMPSN: 7.5K OHM, 5%, 0.25W	01121	CB7525
A10R706	315-0202-00		RES., FXD, CMPSN: 2K OHM, 5%, 0.25W	01121	CB2025
A10R707	315-0132-00		RES., FXD, CMPSN: 1.3K OHM, 5%, 0.25W	01121	CB1325
A10R708	321-0271-00		RES., FXD, FILM: 6.49K OHM, 1%, 0.125W	91637	MFF1816G64900F
A10R709	311-1560-00		RES., VAR, NONWIR: 5K OHM, 20%, 0.50W	73138	91-82-0
A10R711	315-0272-00		RES., FXD, CMPSN: 2.7K OHM, 5%, 0.25W	01121	CB2725
A10R712	315-0512-00		RES., FXD, CMPSN: 5.1K OHM, 5%, 0.25W	01121	CB5125
A10R745	315-0221-00		RES., FXD, CMPSN: 220 OHM, 5%, 0.25W	01121	CB2215
A10R746	321-0134-00		RES., FXD, FILM: 243 OHM, 1%, 0.125W	91637	MFF1816G243R0F
A10R748	321-0230-00		RES., FXD, FILM: 2.43K OHM, 1%, 0.125W	91637	MFF1816G24300F
A10R749	321-0271-00		RES., FXD, FILM: 6.49K OHM, 1%, 0.125W	91637	MFF1816G64900F
A10R751	321-0180-00		RES., FXD, FILM: 732 OHM, 1%, 0.125W	91637	MFF1816G732R0F
A10R752	311-1560-00		RES., VAR, NONWIR: 5K OHM, 20%, 0.50W	73138	91-82-0
A10R753	321-0217-00		RES., FXD, FILM: 1.78K OHM, 1%, 0.125W	91637	MFF1816G17800F
A10R754	315-0100-00		RES., FXD, CMPSN: 10 OHM, 5%, 0.25W	01121	CB1005
A10R756	315-0681-00		RES., FXD, CMPSN: 680 OHM, 5%, 0.25W	01121	CB6815

Replaceable Electrical Parts—2215 Service

Component No.	Tektronix Part No.	Serial/Model No. Eff Dscont	Name & Description	Mfr Code	Mfr Part Number
A10R757	315-0103-00		RES., FXD, CMPSN:10K OHM, 5%, 0.25W	01121	CB1035
A10R758	311-1559-00		RES., VAR, NONWIR:10K OHM, 20%, 0.50W	73138	91-81-0
A10R760	315-0681-00		RES., FXD, CMPSN:680 OHM, 5%, 0.25W	01121	CB6815
A10R761	321-0180-00		RES., FXD, FILM:732 OHM, 1%, 0.125W	91637	MFF1816G732R0F
A10R762	321-0216-00		RES., FXD, FILM:1.74K OHM, 1%, 0.125W	91637	MFF1816G17400F
A10R763	321-0217-00		RES., FXD, FILM:1.78K OHM, 1%, 0.125W	91637	MFF1816G17800F
A10R765	321-0204-00		RES., FXD, FILM:1.3K OHM, 1%, 0.125W	91637	MFF1816G13000F
A10R766	321-0271-00		RES., FXD, FILM:6.49K OHM, 1%, 0.125W	91637	MFF1816G64900F
A10R768	321-0154-00		RES., FXD, FILM:392 OHM, 1%, 0.125W	91637	MFF1816G392R0F
A10R771	321-0182-00		RES., FXD, FILM:768 OHM, 1%, 0.125W	91637	MFF1816G768R0F
A10R772	315-0273-00		RES., FXD, CMPSN:27K OHM, 5%, 0.25W	01121	CB2735
A10R775	323-0312-00		RES., FXD, FILM:17.4K OHM, 1%, 0.50W	91637	MFF1226G17401F
A10R776	321-0189-00		RES., FXD, FILM:909 OHM, 1%, 0.125W	91637	MFF1816G909R0F
A10R777	315-0470-00		RES., FXD, CMPSN:47 OHM, 5%, 0.25W	01121	CB4705
A10R778	315-0101-00		RES., FXD, CMPSN:100 OHM, 5%, 0.25W	01121	CB1015
A10R779	315-0273-00		RES., FXD, CMPSN:27K OHM, 5%, 0.25W	01121	CB2735
A10R780	321-0209-00		RES., FXD, FILM:1.47K OHM, 1%, 0.125W	91637	MFF1816G14700F
A10R781	321-0201-00		RES., FXD, FILM:1.21K OHM, 1%, 0.125W	91637	MFF1816G12100F
A10R782	315-0273-00		RES., FXD, CMPSN:27K OHM, 5%, 0.25W	01121	CB2735
A10R785	323-0312-00		RES., FXD, FILM:17.4K OHM, 1%, 0.50W	91637	MFF1226G17401F
A10R786	321-0189-00		RES., FXD, FILM:909 OHM, 1%, 0.125W	91637	MFF1816G909R0F
A10R787	315-0470-00		RES., FXD, CMPSN:47 OHM, 5%, 0.25W	01121	CB4705
A10R788	315-0101-00		RES., FXD, CMPSN:100 OHM, 5%, 0.25W	01121	CB1015
A10R789	315-0273-00		RES., FXD, CMPSN:27K OHM, 5%, 0.25W	01121	CB2735
A10R792	321-0265-00		RES., FXD, FILM:5.62K OHM, 1%, 0.125W	91637	MFF1816G56200F
A10R793	321-0382-00		RES., FXD, FILM:93.1K OHM, 1%, 0.125W	91637	MFF1816G93101F
A10R796	315-0100-00		RES., FXD, CMPSN:10 OHM, 5%, 0.25W	01121	CB1005
A10R797	315-0100-00		RES., FXD, CMPSN:10 OHM, 5%, 0.25W	01121	CB1005
A10R798	315-0100-00		RES., FXD, CMPSN:10 OHM, 5%, 0.25W	01121	CB1005
A10R799	315-0100-00		RES., FXD, CMPSN:10 OHM, 5%, 0.25W	01121	CB1005
A10R801	301-0472-00		RES., FXD, CMPSN:4.7K OHM, 5%, 0.50W	01121	EB4725
A10R802	301-0472-00		RES., FXD, CMPSN:4.7K OHM, 5%, 0.50W	01121	EB4725
A10R803	315-0102-00		RES., FXD, CMPSN:1K OHM, 5%, 0.25W	01121	CB1025
A10R809	315-0134-00		RES., FXD, CMPSN:130K OHM, 5%, 0.25W	01121	CB1345
A10R810	315-0103-00		RES., FXD, CMPSN:10K OHM, 5%, 0.25W	01121	CB1035
A10R811	315-0683-00		RES., FXD, CMPSN:68K OHM, 5%, 0.25W	01121	CB6835
A10R812	315-0182-00		RES., FXD, CMPSN:1.8K OHM, 5%, 0.25W	01121	CB1825
A10R813	315-0473-00		RES., FXD, CMPSN:47K OHM, 5%, 0.25W	01121	CB4735
A10R814	321-0394-00		RES., FXD, FILM:124K OHM, 1%, 0.125W	91637	MFF1816G12402F
A10R816	321-0118-00		RES., FXD, FILM:165 OHM, 1%, 0.125W	91637	MFF1816G165R0F
A10R817	321-0157-00		RES., FXD, FILM:422 OHM, 1%, 0.125W	91637	MFF1816G422R0F
A10R820	315-0102-00		RES., FXD, CMPSN:1K OHM, 5%, 0.25W	01121	CB1025
A10R821	315-0104-00		RES., FXD, CMPSN:100K OHM, 5%, 0.25W	01121	CB1045
A10R822	315-0511-00		RES., FXD, CMPSN:510 OHM, 5%, 0.25W	01121	CB5115
A10R825	315-0104-00		RES., FXD, CMPSN:100K OHM, 5%, 0.25W	01121	CB1045
A10R826	315-0102-00		RES., FXD, CMPSN:1K OHM, 5%, 0.25W	01121	CB1025
A10R827	321-0379-00		RES., FXD, FILM:86.6K OHM, 1%, 0.125W	91637	MFF1816G86601F
A10R828	321-0291-00		RES., FXD, FILM:10.5K OHM, 1%, 0.125W	91637	MFF1816G10501F
A10R829	321-0197-00		RES., FXD, FILM:1.1K OHM, 1%, 0.125W	91637	MFF1816G11000F
A10R830	315-0123-00		RES., FXD, CMPSN:12K OHM, 5%, 0.25W	01121	CB1235
A10R831	315-0431-00		RES., FXD, CMPSN:430 OHM, 5%, 0.25W	01121	CB4315
A10R834	315-0304-00		RES., FXD, CMPSN:300K OHM, 5%, 0.25W	01121	CB3045
A10R835	315-0395-00		RES., FXD, CMPSN:3.9M OHM, 5%, 0.25W	01121	CB3955
A10R836	315-0821-00		RES., FXD, CMPSN:820 OHM, 5%, 0.25W	01121	CB8215
A10R837	315-0302-00		RES., FXD, CMPSN:3K OHM, 5%, 0.25W	01121	CB3025
A10R839	315-0472-00		RES., FXD, CMPSN:4.7K OHM, 5%, 0.25W	01121	CB4725
A10R840	321-0241-00		RES., FXD, FILM:3.16K OHM, 1%, 0.125W	91637	MFF1816G31600F

Replaceable Electrical Parts—2215 Service

Component No.	Tektronix Part No.	Serial/Model No. Eff Dscont	Name & Description	Mfr Code	Mfr Part Number
A10R841	321-0149-00		RES., FXD, FILM: 348 OHM, 1%, 0.125W	91637	MFF1816G348R0F
A10R841	315-0821-00		RES., FXD, CMPSN: 820 OHM, 5%, 0.25W	01121	CB8215
A10R842	321-0261-00		RES., FXD, FILM: 5.11K OHM, 1%, 0.125W	91637	MFF1816G51100F
A10R844	321-0230-00		RES., FXD, FILM: 2.43K OHM, 1%, 0.125W	91637	MFF1816G24300F
A10R845	321-0221-00		RES., FXD, FILM: 1.96K OHM, 1%, 0.125W	91637	MFF1816G19600F
A10R846	321-0332-00		RES., FXD, FILM: 28K OHM, 1%, 0.125W	91637	MFF1816G28001F
A10R847	315-0102-00		RES., FXD, CMPSN: 1K OHM, 5%, 0.25W	01121	CB1025
A10R849	315-0270-00		RES., FXD, CMPSN: 27 OHM, 5%, 0.25W	01121	CB2705
A10R850	315-0471-00		RES., FXD, CMPSN: 470 OHM, 5%, 0.25W	01121	CB4715
A10R851	315-0222-00		RES., FXD, CMPSN: 2.2K OHM, 5%, 0.25W	01121	CB2225
A10R852	315-0104-00		RES., FXD, CMPSN: 100K OHM, 5%, 0.25W	01121	CB1045
A10R854	315-0180-00	XB012543	RES., FXD, CMPSN: 18 OHM, 5%, 0.25W	01121	CB1805
A10R856	315-0470-00		RES., FXD, CMPSN: 47 OHM, 5%, 0.25W	01121	CB4705
A10R860	311-1558-00		RES., VAR, NONWIR: 20K OHM, 20%, 0.50W	73138	91-80-0
A10R861	315-0203-00		RES., FXD, CMPSN: 20K OHM, 5%, 0.25W	01121	CB2035
A10R863	315-0474-00		RES., FXD, CMPSN: 470K OHM, 5%, 0.25W	01121	CB4745
A10R864	315-0472-03		RES., FXD, CMPSN: 4.7K OHM, 5%, 0.25W	01121	CB4725
A10R865	315-0470-03		RES., FXD, CMPSN: 47 OHM, 5%, 0.25W	01121	CB4705
A10R867	315-0511-02		RES., FXD, CMPSN: 510 OHM, 25W, 5%, A-B ONLY	01121	CB5115
A10R868	315-0226-01		RES., FXD, CMPSN: 22M OHM, 5%, 0.25W	01121	CB2265
A10R870	311-1555-00		RES., VAR, NONWIR: 100K OHM, 20%, 0.5W	73138	91-77-0
A10R871	315-0471-00		RES., FXD, CMPSN: 470 OHM, 5%, 0.25W	01121	CB4715
A10R872	315-0102-00		RES., FXD, CMPSN: 1K OHM, 5%, 0.25W	01121	CB1025
A10R873	315-0513-00		RES., FXD, CMPSN: 51K OHM, 5%, 0.25W	01121	CB5135
A10R874	315-0433-00		RES., FXD, CMPSN: 43K OHM, 5%, 0.25W	01121	CB4335
A10R875	311-1550-00		RES., VAR, NONWIR: 2M OHM, 20%, 0.50W	73138	91-72-0
A10R876	315-0471-00		RES., FXD, CMPSN: 470 OHM, 5%, 0.25W	01121	CB4715
A10R877	315-0183-00		RES., FXD, CMPSN: 18K OHM, 5%, 0.25W	01121	CB1835
A10R878	301-0105-00		RES., FXD, CMPSN: 1M OHM, 5%, 0.50W	01121	EB1055
A10R879	301-0105-00		RES., FXD, CMPSN: 1M OHM, 5%, 0.50W	01121	EB1055
A10R880	301-0105-00		RES., FXD, CMPSN: 1M OHM, 5%, 0.50W	01121	EB1055
A10R881	301-0105-00		RES., FXD, CMPSN: 1M OHM, 5%, 0.50W	01121	EB1055
A10R882	301-0105-00		RES., FXD, CMPSN: 1M OHM, 5%, 0.50W	01121	EB1055
A10R883	311-1933-00		RES., VAR, NONWIR: PNL, 5M OHM, 10%, 0.50W	01121	17M095
A10R884	301-0105-00		RES., FXD, CMPSN: 1M OHM, 5%, 0.50W	01121	EB1055
A10R886	315-0471-00		RES., FXD, CMPSN: 470 OHM, 5%, 0.25W	01121	CB4715
A10R887	311-1555-00		RES., VAR, NONWIR: 100K OHM, 20%, 0.5W	73138	91-77-0
A10R911	301-0184-00		RES., FXD, CMPSN: 180K OHM, 5%, 0.50W	01121	EB1845
A10R912	315-0104-00		RES., FXD, CMPSN: 100K OHM, 5%, 0.25W	01121	CB1045
A10R914	301-0184-00		RES., FXD, CMPSN: 180K OHM, 5%, 0.50W	01121	EB1845
A10R915	321-0230-00		RES., FXD, FILM: 2.43K OHM, 1%, 0.125W	91637	MFF1816G24300F
A10R916	315-0223-00		RES., FXD, CMPSN: 22K OHM, 5%, 0.25W	01121	CB2235
A10R917	315-0154-00		RES., FXD, CMPSN: 150K OHM, 5%, 0.25W	01121	CB1545
A10R918	315-0753-00		RES., FXD, CMPSN: 75K OHM, 5%, 0.25W	01121	CB7535
A10R920	301-0105-00		RES., FXD, CMPSN: 1M OHM, 5%, 0.50W	01121	EB1055
A10R925	315-0510-00		RES., FXD, CMPSN: 51 OHM, 5%, 0.25W	01121	CB5105
A10R926	301-0471-00		RES., FXD, CMPSN: 470 OHM, 5%, 0.50W	01121	EB4715
A10R940	315-0470-00		RES., FXD, CMPSN: 47 OHM, 5%, 0.25W	01121	CB4705
A10R941	308-0677-00		RES., FXD, WW: 1 OHM, 5%, 2W	75042	BWH-1R000J
A10R942	315-0470-00		RES., FXD, CMPSN: 47 OHM, 5%, 0.25W	01121	CB4705
A10R945	321-0234-00		RES., FXD, FILM: 2.67K OHM, 1%, 0.125W	91637	MFF1816G26700F
A10R946	311-1248-00		RES., VAR, NONWIR: 500 OHM, 10%, 0.50W	73138	72-23-0
A10R947	321-0304-00		RES., FXD, FILM: 14.3K OHM, 1%, 0.125W	91637	MFF1816G14301F
A10R948	315-0102-00		RES., FXD, CMPSN: 1K OHM, 5%, 0.25W	01121	CB1025
A10R950	315-0102-00		RES., FXD, CMPSN: 1K OHM, 5%, 0.25W	01121	CB1025
A10R951	301-0472-00		RES., FXD, CMPSN: 4.7K OHM, 5%, 0.50W	01121	EB4725
A10R952	311-1562-00		RES., VAR, NONWIR: 2K OHM, 20%, 0.50W	73138	91-84-0

Component No.	Tektronix Part No.	Serial/Model No. Eff Dscont	Name & Description	Mfr Code	Mfr Part Number
A10R953	315-0361-00		RES., FXD, CMPSN: 360 OHM, 5%, 0.25W	01121	CB3615
A10R954	315-0102-00		RES., FXD, CMPSN: 1K OHM, 5%, 0.25W	01121	CB1025
A10R956	301-0622-00		RES., FXD, CMPSN: 6.2K OHM, 5%, 0.50W	01121	EB6225
A10R990	315-0101-00		RES., FXD, CMPSN: 100 OHM, 5%, 0.25W	01121	CB1015
A10R992	315-0682-03		RES., FXD, CMPSN: 6.8K OHM, 5%, 0.25 W	01121	CB6825
A10R994	315-0682-03		RES., FXD, CMPSN: 6.8K OHM, 5%, 0.25 W	01121	CB6825
A10R995	315-0101-03		RES., FXD, CMPSN: 100 OHM, 5%, 0.25W	01121	CB1015
A10RT356	307-0125-00		RES., THERMAL: 500 OHM, 10%, 25 DEG C	50157	2D1595
A10S901	260-1849-00		SWITCH, PUSH: DPDT, 4A, 250VAC, W/BRKT	31918	OBD
A10T448	120-1401-00		XFMR, TRIG:	54937	OBD
A10T925	120-1384-00		TRANSFORMER, RF: TOROID, 2 WINDS	80009	120-1384-00
A10T940	120-1348-00		XFMR, PWR, SDN&SU: HIGH VOLTAGE	80009	120-1348-00
A10T942	120-1347-00		TRANSFORMER, RF: DRIVER SATURATING POT CORE	80009	120-1347-00
A10TP444	214-0579-00		TERM, TEST POINT: BRS CD PL	80009	214-0579-00
A10TP500	214-0579-00		TERM, TEST POINT: BRS CD PL	80009	214-0579-00
A10TP501	214-0579-00		TERM, TEST POINT: BRS CD PL	80009	214-0579-00
A10TP854	214-0579-00		TERM, TEST POINT: BRS CD PL	80009	214-0579-00
A10TP915	214-0579-00		TERM, TEST POINT: BRS CD PL	80009	214-0579-00
A10TP920	214-0579-00		TERM, TEST POINT: BRS CD PL	80009	214-0579-00
A10TP934	214-0579-00		TERM, TEST POINT: BRS CD PL	80009	214-0579-00
A10TP951	214-0579-00		TERM, TEST POINT: BRS CD PL	80009	214-0579-00
A10TP952	214-0579-00		TERM, TEST POINT: BRS CD PL	80009	214-0579-00
A10U170	156-1294-00		MICROCIRCUIT, LI: FIVE NPN TRANSISTOR ARRAY	80009	156-1294-00
A10U197	156-0048-00		MICROCIRCUIT, LI: FIVE NPN TRANSISTOR ARRAY	02735	CA3046
A10U270	156-1294-00		MICROCIRCUIT, LI: FIVE NPN TRANSISTOR ARRAY	80009	156-1294-00
A10U305	156-0728-00		MICROCIRCUIT, DI: QUAD 2-INP POS AND GATES	27014	DM74LS09
A10U310	156-0721-00	B010100 B012542	MICROCIRCUIT, DI: ST POS-NAND GATES W/TP OUT	27014	DM74LS132N
A10U310	156-0721-02	B012543	MICROCIRCUIT, DI: QUAD 2-IN NAND SCHMITT TRI	04713	SN74LS132NDS
A10U315	156-0384-00		MICROCIRCUIT, DI: QUAD 2-INPUT NAND GATE	80009	156-0384-00
A10U317	156-0388-00		MICROCIRCUIT, DI: DUAL D-TYPE FLIP-FLOP	80009	156-0388-00
A10U421	156-1294-00		MICROCIRCUIT, LI: FIVE NPN TRANSISTOR ARRAY	80009	156-1294-00
A10U460	156-0534-00		MICROCIRCUIT, LI: DUAL DIFF AMPL, 14 LD DIP	80009	156-0534-00
A10U480	156-0205-00		MICROCIRCUIT, DI: QUAD 2-INPUT NOR GATE	04713	MC10102 (P OR L)
A10U507	156-0158-00		MICROCIRCUIT, LI: DUAL OPERATIONAL AMPLIFIER	18324	MC1458V
A10U603	156-1611-00		MICROCIRCUIT, DI: DUAL D TYPE EDGE-TRIGGERED	07263	74F74
A10U607	156-0180-00		MICROCIRCUIT, DI: QUAD 2-INPUT NAND GATE	01295	SN74S00(N OR J)
A10U620	156-0875-02		MICROCIRCUIT, DI: DUAL 2-W/2 INP AOI GATES	01295	SN74LS51
A10U640	156-0405-00		MICROCIRCUIT, DI: DUAL RETRIG MONOSTABLE MV	07263	9602 (PC OR DC)
A10U825	156-0515-00		MICROCIRCUIT, DI: TRIPLE 3-CHAN MUX	80009	156-0515-00
A10U835	156-1191-00		MICROCIRCUIT, LI: DUAL BI-FET OP-AMPL, 8 DIP	01295	TL072CP
A10U931	156-0885-00		MICROCIRCUIT, LI: OPTOELECTRONIC ISOLATOR	04713	SOC123A
A10U985	156-1263-00		MICROCIRCUIT, LI: VOLTAGE REGULATOR	27014	LM341P-5.0TB
A10U990	152-0791-00		SEMICONV DEVICE: V MULTR, 4KV IN, 8KV DC OUT	14099	SCMA10921
A10VR483	152-0662-00		SEMICONV DEVICE: ZENER, 0.4W, 5V, 1%	04713	SZG195
A10VR644	152-0278-00		SEMICONV DEVICE: ZENER, 0.4W, 3V, 5%	04713	SZG35009K20
A10VR657	152-0317-00		SEMICONV DEVICE: ZENER, 0.25W, 6.2V, 5%	04713	SZG20012
A10VR781	152-0243-00		SEMICONV DEVICE: ZENER, 0.4W, 15V, 5%	14552	TD3810983
A10VR809	152-0127-00		SEMICONV DEVICE: ZENER, 0.4W, 7.5V, 5%	04713	SZG35009K2
A10VR847	152-0662-00		SEMICONV DEVICE: ZENER, 0.4W, 5V, 1%	04713	SZG195
A10VR901	307-0456-00		RES, V SENSITIVE:	03508	M0V-V250LA15A
A10VR913	152-0304-00		SEMICONV DEVICE: ZENER, 0.4W, 20V, 5%	15238	Z5411
A10VR914	152-0149-00		SEMICONV DEVICE: ZENER, 0.4W, 10V, 5%	04713	SZG35009K3
A10VR915	152-0149-00		SEMICONV DEVICE: ZENER, 0.4W, 10V, 5%	04713	SZG35009K3
A10VR938	152-0788-00		SEMICONV DEVICE: TRANSIENT SUPPRESSOR	24444	5KP45
A10VR951	152-0317-00		SEMICONV DEVICE: ZENER, 0.25W, 6.2V, 5%	04713	SZG20012
A10W170	131-0566-00		BUS CONDUCTOR: DUMMY RES, 2.375, 22 AWG	55210	L-2007-1
A10W197	131-0566-00		BUS CONDUCTOR: DUMMY RES, 2.375, 22 AWG	55210	L-2007-1

**Replaceable Electrical Parts—2215 Service**

Component No.	Tektronix Part No.	Serial/Model No. Eff Dscont	Name & Description	Mfr Code	Mfr Part Number
A10W198	131-0566-00		BUS CONDUCTOR:DUMMY RES,2.375,22 AWG	55210	L-2007-1
A10W199	131-0566-00		BUS CONDUCTOR:DUMMY RES,2.375,22 AWG	55210	L-2007-1
A10W297	131-0566-00		BUS CONDUCTOR:DUMMY RES,2.375,22 AWG	55210	L-2007-1
A10W298	131-0566-00		BUS CONDUCTOR:DUMMY RES,2.375,22 AWG	55210	L-2007-1
A10W299	131-0566-00		BUS CONDUCTOR:DUMMY RES,2.375,22 AWG	55210	L-2007-1
A10W300	131-0566-00		BUS CONDUCTOR:DUMMY RES,2.375,22 AWG	55210	L-2007-1
A10W301	131-0566-00		BUS CONDUCTOR:DUMMY RES,2.375,22 AWG	55210	L-2007-1
A10W308	131-0566-00		BUS CONDUCTOR:DUMMY RES,2.375,22 AWG	55210	L-2007-1
A10W309	131-0566-00		BUS CONDUCTOR:DUMMY RES,2.375,22 AWG	55210	L-2007-1
A10W310	131-0566-00		BUS CONDUCTOR:DUMMY RES,2.375,22 AWG	55210	L-2007-1
A10W311	131-0566-00		BUS CONDUCTOR:DUMMY RES,2.375,22 AWG	55210	L-2007-1
A10W312	131-0566-00		BUS CONDUCTOR:DUMMY RES,2.375,22 AWG	55210	L-2007-1
A10W314	131-0566-00		BUS CONDUCTOR:DUMMY RES,2.375,22 AWG	55210	L-2007-1
A10W315	131-0566-00		BUS CONDUCTOR:DUMMY RES,2.375,22 AWG	55210	L-2007-1
A10W380	131-0566-00		BUS CONDUCTOR:DUMMY RES,2.375,22 AWG	55210	L-2007-1
A10W392	131-0566-00		BUS CONDUCTOR:DUMMY RES,2.375,22 AWG	55210	L-2007-1
A10W397	131-0566-00		BUS CONDUCTOR:DUMMY RES,2.375,22 AWG	55210	L-2007-1
A10W399	131-0566-00		BUS CONDUCTOR:DUMMY RES,2.375,22 AWG	55210	L-2007-1
A10W418	131-0566-00		BUS CONDUCTOR:DUMMY RES,2.375,22 AWG	55210	L-2007-1
A10W421	131-0566-00		BUS CONDUCTOR:DUMMY RES,2.375,22 AWG	55210	L-2007-1
A10W422	131-0566-00		BUS CONDUCTOR:DUMMY RES,2.375,22 AWG	55210	L-2007-1
A10W430	131-0566-00		BUS CONDUCTOR:DUMMY RES,2.375,22 AWG	55210	L-2007-1
A10W431	131-0566-00		BUS CONDUCTOR:DUMMY RES,2.375,22 AWG	55210	L-2007-1
A10W432	131-0566-00		BUS CONDUCTOR:DUMMY RES,2.375,22 AWG	55210	L-2007-1
A10W444	131-0566-00		BUS CONDUCTOR:DUMMY RES,2.375,22 AWG	55210	L-2007-1
A10W447	131-0566-00		BUS CONDUCTOR:DUMMY RES,2.375,22 AWG	55210	L-2007-1
A10W448	131-0566-00		BUS CONDUCTOR:DUMMY RES,2.375,22 AWG	55210	L-2007-1
A10W470	131-0566-00		BUS CONDUCTOR:DUMMY RES,2.375,22 AWG	55210	L-2007-1
A10W472	131-0566-00		BUS CONDUCTOR:DUMMY RES,2.375,22 AWG	55210	L-2007-1
A10W507	131-0566-00		BUS CONDUCTOR:DUMMY RES,2.375,22 AWG	55210	L-2007-1
A10W508	131-0566-00		BUS CONDUCTOR:DUMMY RES,2.375,22 AWG	55210	L-2007-1
A10W519	131-0566-00		BUS CONDUCTOR:DUMMY RES,2.375,22 AWG	55210	L-2007-1
A10W564	131-0566-00		BUS CONDUCTOR:DUMMY RES,2.375,22 AWG	55210	L-2007-1
A10W571	131-0566-00		BUS CONDUCTOR:DUMMY RES,2.375,22 AWG	55210	L-2007-1
A10W606	131-0566-00		BUS CONDUCTOR:DUMMY RES,2.375,22 AWG	55210	L-2007-1
A10W616	131-0566-00		BUS CONDUCTOR:DUMMY RES,2.375,22 AWG	55210	L-2007-1
A10W640	131-0566-00		BUS CONDUCTOR:DUMMY RES,2.375,22 AWG	55210	L-2007-1
A10W646	131-0566-00		BUS CONDUCTOR:DUMMY RES,2.375,22 AWG	55210	L-2007-1
A10W650	131-0566-00		BUS CONDUCTOR:DUMMY RES,2.375,22 AWG	55210	L-2007-1
A10W652	131-0566-00		BUS CONDUCTOR:DUMMY RES,2.375,22 AWG	55210	L-2007-1
A10W674	131-0566-00		BUS CONDUCTOR:DUMMY RES,2.375,22 AWG	55210	L-2007-1
A10W696	131-0566-00		BUS CONDUCTOR:DUMMY RES,2.375,22 AWG	55210	L-2007-1
A10W704	131-0566-00		BUS CONDUCTOR:DUMMY RES,2.375,22 AWG	55210	L-2007-1
A10W763	131-0566-00		BUS CONDUCTOR:DUMMY RES,2.375,22 AWG	55210	L-2007-1
A10W764	131-0566-00		BUS CONDUCTOR:DUMMY RES,2.375,22 AWG	55210	L-2007-1
A10W835	131-0566-00		BUS CONDUCTOR:DUMMY RES,2.375,22 AWG	55210	L-2007-1
A10W836	131-0566-00		BUS CONDUCTOR:DUMMY RES,2.375,22 AWG	55210	L-2007-1
A10W840	131-0566-00		BUS CONDUCTOR:DUMMY RES,2.375,22 AWG	55210	L-2007-1
A10W841	131-0566-00		BUS CONDUCTOR:DUMMY RES,2.375,22 AWG	55210	L-2007-1
A10W842	131-0566-00		BUS CONDUCTOR:DUMMY RES,2.375,22 AWG	55210	L-2007-1
A10W843	131-0566-00		BUS CONDUCTOR:DUMMY RES,2.375,22 AWG	55210	L-2007-1
A10W844	131-0566-00		BUS CONDUCTOR:DUMMY RES,2.375,22 AWG	55210	L-2007-1
A10W845	131-0566-00		BUS CONDUCTOR:DUMMY RES,2.375,22 AWG	55210	L-2007-1
A10W846	131-0566-00		BUS CONDUCTOR:DUMMY RES,2.375,22 AWG	55210	L-2007-1
A10W847	131-0566-00		BUS CONDUCTOR:DUMMY RES,2.375,22 AWG	55210	L-2007-1
A10W877	131-0566-00		BUS CONDUCTOR:DUMMY RES,2.375,22 AWG	55210	L-2007-1
A10W878	131-0566-00		BUS CONDUCTOR:DUMMY RES,2.375,22 AWG	55210	L-2007-1



Component No.	Tektronix Part No.	Serial/Model No. Eff Dscont	Name & Description	Mfr Code	Mfr Part Number
A10W887	131-0566-00		BUS CONDUCTOR:DUMMY RES,2.375,22 AWG	55210	L-2007-1
A10W964	131-0566-00		BUS CONDUCTOR:DUMMY RES,2.375,22 AWG	55210	L-2007-1
A10W965	131-0566-00		BUS CONDUCTOR:DUMMY RES,2.375,22 AWG	55210	L-2007-1
A10W966	131-0566-00		BUS CONDUCTOR:DUMMY RES,2.375,22 AWG	55210	L-2007-1
A10W967	131-0566-00		BUS CONDUCTOR:DUMMY RES,2.375,22 AWG	55210	L-2007-1
A10W968	131-0566-00		BUS CONDUCTOR:DUMMY RES,2.375,22 AWG	55210	L-2007-1
A10W969	131-0566-00		BUS CONDUCTOR:DUMMY RES,2.375,22 AWG	55210	L-2007-1
A10W975	131-0566-00		BUS CONDUCTOR:DUMMY RES,2.375,22 AWG	55210	L-2007-1
A10W976	131-0566-00		BUS CONDUCTOR:DUMMY RES,2.375,22 AWG	55210	L-2007-1
A10W982	131-0566-00		BUS CONDUCTOR:DUMMY RES,2.375,22 AWG	55210	L-2007-1
A10W985	131-0566-00		BUS CONDUCTOR:DUMMY RES,2.375,22 AWG	55210	L-2007-1
A10W986	131-0566-00		BUS CONDUCTOR:DUMMY RES,2.375,22 AWG	55210	L-2007-1
A10W1010	131-1817-00		LINK,TERM CONNE:22 AWG,2.25" LONG	80009	131-1817-00
			THRU		
A10W1039	131-1817-00		LINK,TERM CONNE:22 AWG,2.25" LONG	80009	131-1817-00

Replaceable Electrical Parts—2215 Service

Component No.	Tektronix Part No.	Serial/Model No. Eff Dscnt	Name & Description	Mfr Code	Mfr Part Number
All	-----		CKT BOARD ASSY:FRONT PANEL		
A11C101	281-0862-00		CAP.,FXD,CER DI:0.001UF,+80-20%,100V	20932	401-ES-100-AD102
A11C202	285-0515-00		CAP.,FXD,PLSTC:0.022UF,20%,400V	56289	192P22304
A11C265	281-0773-00		CAP.,FXD,CER DI:0.01UF,10%,100V	04222	GC70-1C103K
A11C313	281-0773-00		CAP.,FXD,CER DI:0.01UF,10%,100V	04222	GC70-1C103K
A11C314	281-0773-00		CAP.,FXD,CER DI:0.01UF,10%,100V	04222	GC70-1C103K
A11C315	281-0773-00		CAP.,FXD,CER DI:0.01UF,10%,100V	04222	GC70-1C103K
A11C402	283-0006-00		CAP.,FXD,CER DI:0.02UF,+80-20%,500V	72982	0841545Z5V00203Z
A11C403	283-0331-00		CAP.,FXD,CER DI:43PF,2%,100V	72982	805-505A430G
A11C404	283-0342-00		CAP.,FXD,CER DI:6.5PF,0.5%,2000V	91418	HV6R5D2024R0
A11C531	281-0773-00		CAP.,FXD,CER DI:0.01UF,10%,100V	04222	GC70-1C103K
A11C650	281-0773-00		CAP.,FXD,CER DI:0.01UF,10%,100V	04222	GC70-1C103K
A11C725	290-0745-00		CAP.,FXD,ELCLT:22UF,+50-10%,25V	56289	502D225
A11C726	281-0775-00		CAP.,FXD,CER DI:0.1UF,20%,50V	72982	8005D9AABZ5U104M
A11CR536	152-0141-02		SEMICONV DEVICE:SILICON,30V,150MA	01295	1N4152R
A11CR538	152-0141-02		SEMICONV DEVICE:SILICON,30V,150MA	01295	1N4152R
A11CR701	152-0141-02		SEMICONV DEVICE:SILICON,30V,150MA	01295	1N4152R
A11CR702	152-0141-02		SEMICONV DEVICE:SILICON,30V,150MA	01295	1N4152R
A11CR703	152-0141-02		SEMICONV DEVICE:SILICON,30V,150MA	01295	1N4152R
A11CR705	152-0141-02		SEMICONV DEVICE:SILICON,30V,150MA	01295	1N4152R
A11CR706	152-0141-02		SEMICONV DEVICE:SILICON,30V,150MA	01295	1N4152R
A11DS618	150-1029-00		LT EMITTING DIO:GREEN,565NM,35MA	53184	XC209G
A11J1000	131-0608-00	-----	TERMINAL,PIN:0.365 L X 0.025 PH BRZ GOLD (QTY 4)	22526	47357
A11J2000	131-0787-00	-----	CONTACT,ELEC:0.64 INCH LONG (QTY 10)	22526	47359
A11R100	307-0107-00		RES.,FXD,CMPSN:5.6 OHM,5%,0.25W	01121	CB56G5
A11R101	315-0750-00		RES.,FXD,CMPSN:75 OHM,5%,0.25W	01121	CB7505
A11R102	315-0105-00		RES.,FXD,CMPSN:1M OHM,5%,0.25W	01121	CB1055
A11R190	311-2147-00		RES.,VAR,NONWIR:PNL,5K OHM,20%,0.50W	12697	CM41769
A11R191	321-0257-00		RES.,FXD,FILM:4.64K OHM,1%,0.125W	91637	MFF1816G46400F
A11R200	307-0107-00		RES.,FXD,CMPSN:5.6 OHM,5%,0.25W	01121	CB56G5
A11R201	315-0750-00		RES.,FXD,CMPSN:75 OHM,5%,0.25W	01121	CB7505
A11R202	315-0105-00		RES.,FXD,CMPSN:1M OHM,5%,0.25W	01121	CB1055
A11R290	311-2147-00		RES.,VAR,NONWIR:PNL,5K OHM,20%,0.50W	12697	CM41769
A11R291	321-0257-00		RES.,FXD,FILM:4.64K OHM,1%,0.125W	91637	MFF1816G46400F
A11R395	311-2147-00		RES.,VAR,NONWIR:PNL,5K OHM,20%,0.50W	12697	CM41769
A11R401	315-0820-00		RES.,FXD,CMPSN:82 OHM,5%,0.25W	01121	CB8205
A11R402	321-0807-00		RES.,FXD,FILM:900K OHM,1%,0.125W	91637	HFF1104F90002F
A11R403	321-0617-00		RES.,FXD,FILM:111K OHM,1%,0.125W	91637	MFF1816G11102F
A11R404	321-0468-00		RES.,FXD,FILM:732K OHM,1%,0.125W	24546	NA4D7323F
A11R405	315-0101-00		RES.,FXD,CMPSN:100 OHM,5%,0.25W	01121	CB1015
A11R455	311-2149-00		RES.,VAR,NONWIR:PNL,250 OHM,20%,0.50W	12697	CM43491
A11R530	315-0124-00		RES.,FXD,CMPSN:120K OHM,5%,0.25W	01121	CB1245
A11R531	315-0124-00		RES.,FXD,CMPSN:120K OHM,5%,0.25W	01121	CB1245
A11R532	315-0434-00		RES.,FXD,CMPSN:430K OHM,5%,0.25W	01121	CB4345
A11R536	315-0182-00		RES.,FXD,CMPSN:1.8K OHM,5%,0.25W	01121	CB1825
A11R537	321-0239-00		RES.,FXD,FILM:3.01K OHM,1%,0.125W	91637	MFF1816G30100F
A11R538	321-0126-00		RES.,FXD,FILM:200 OHM,1%,0.125W	91637	MFF1816G200R0F
A11R557	311-2148-00		RES.,VAR,NONWIR:PNL,20K OHM,20%,0.50W	12697	CM41770
A11R645	315-0912-00		RES.,FXD,CMPSN:9.1K OHM,5%,0.25W	01121	CB9125
A11R646	315-0123-00		RES.,FXD,CMPSN:12K OHM,5%,0.25W	01121	CB1235
A11R726	311-2147-00		RES.,VAR,NONWIR:PNL,5K OHM,20%,0.50W	12697	CM41769
A11R807	311-2147-00		RES.,VAR,NONWIR:PNL,5K OHM,20%,0.50W	12697	CM41769
A11R808	315-0512-00		RES.,FXD,CMPSN:5.1K OHM,5%,0.25W	01121	CB5125
A11R891	311-1562-00		RES.,VAR,NONWIR:2K OHM,20%,0.50W	73138	91-84-0
A11R975	301-0131-00		RES.,FXD,CMPSN:130 OHM,5%,0.50W	01121	EB1315

Component No.	Tektronix Part No.	Serial/Model No.		Name & Description	Mfr	
		Eff	Dscont		Code	Mfr Part Number
A11S101	260-2033-00			SWITCH, SLIDE: DPTT, 125V, 0.5A	82389	OBD
A11S201	260-2033-00			SWITCH, SLIDE: DPTT, 125V, 0.5A	82389	OBD
A11S264	260-2075-00			SWITCH, PUSH: SPDT, 50VDC, 500M AMP	80009	260-2075-00
A11S305	260-2033-00			SWITCH, SLIDE: DPTT, 125V, 0.5A	82389	OBD
A11S315	260-2033-00			SWITCH, SLIDE: DPTT, 125V, 0.5A	82389	OBD
A11S317	260-2033-00			SWITCH, SLIDE: DPTT, 125V, 0.5A	82389	OBD
A11S390	260-2076-00			SWITCH, PUSH: SPST, MOMENTARY, 50VDC, 500M AMP	80009	260-2076-00
A11S401	260-2033-00			SWITCH, SLIDE: DPTT, 125V, 0.5A	82389	OBD
A11S440	260-2033-00			SWITCH, SLIDE: DPTT, 125V, 0.5A	82389	OBD
A11S464	260-2032-00			SWITCH, SLIDE: DPDT, 125V, 0.5A	82389	OBD
A11S564	260-2032-00			SWITCH, SLIDE: DPDT, 125V, 0.5A	82389	OBD
A11S611	260-2033-00			SWITCH, SLIDE: DPTT, 125V, 0.5A	82389	OBD
A11S650	260-2033-00			SWITCH, SLIDE: DPTT, 125V, 0.5A	82389	OBD
A11U535	156-0067-00			MICROCIRCUIT, LI: OPERATIONAL AMPLIFIER	02735	85145
A11W264	131-0566-00			BUS CONDUCTOR: DUMMY RES, 2.375, 22 AWG	55210	L-2007-1
A11W265	131-0566-00			BUS CONDUCTOR: DUMMY RES, 2.375, 22 AWG	55210	L-2007-1
A11W630	131-0566-00			BUS CONDUCTOR: DUMMY RES, 2.375, 22 AWG	55210	L-2007-1
A11W636	131-0566-00			BUS CONDUCTOR: DUMMY RES, 2.375, 22 AWG	55210	L-2007-1
A11W638	131-0566-00			BUS CONDUCTOR: DUMMY RES, 2.375, 22 AWG	55210	L-2007-1
A11W702	131-0566-00			BUS CONDUCTOR: DUMMY RES, 2.375, 22 AWG	55210	L-2007-1

Replaceable Electrical Parts—2215 Service

Component No.	Tektronix Part No.	Serial/Model No. Eff Dscont	Name & Description	Mfr Code	Mfr Part Number
A12	-----		CKT BOARD ASSY:ATTEN/SWEEP		
A12C104	281-0078-00		CAP.,VAR,AIR DI:1.4-7.3PF,750V	74970	189-0503-G75
A12C105	281-0214-00		CAP.,VAR,CER DI:0.5-3PF,400V	80031	2502AOR503VP02F0
A12C107	283-0154-00		CAP.,FXD,CER DI:22PF,5%,50V	72982	8111B061COG220J
A12C110	281-0078-00		CAP.,VAR,AIR DI:1.4-7.3PF,750V	74970	189-0503-075
A12C111	281-0214-00		CAP.,VAR,CER DI:0.5-3PF,400V	80031	2502AOR503VP02F0
A12C112	283-0108-00		CAP.,FXD,CER DI:220PF,10%,200V	56289	272C13
A12C119	283-0158-00		CAP.,FXD,CER DI:1PF,10%,50V	72982	8101B057COK0109B
A12C121	283-0000-00		CAP.,FXD,CER DI:0.001UF,+100-0%,500V	59660	831-519-Z5U-102P
A12C123	281-0775-00		CAP.,FXD,CER DI:0.1UF,20%,50V	72982	8005D9AABZ5U104M
A12C125	283-0330-00		CAP.,FXD,CER DI:100PF,5%,50V	51642	150-050-NP0-101J
A12C132	290-0808-00		CAP.,FXD,ELCTLT:2.7UF,10%,20V	56289	162D275X9020CD2
A12C133	283-0000-00		CAP.,FXD,CER DI:0.001UF,+100-0%,500V	59660	831-519-Z5U-102P
A12C134	283-0000-00		CAP.,FXD,CER DI:0.001UF,+100-0%,500V	59660	831-519-Z5U-102P
A12C136	283-0220-00		CAP.,FXD,CER DI:0.01UF,20%,50V	72982	8121N075X7R0103M
A12C137	283-0220-00		CAP.,FXD,CER DI:0.01UF,20%,50V	72982	8121N075X7R0103M
A12C139	283-0160-00		CAP.,FXD,CER DI:1.5PF,10%,50V	72982	8101A058COK159B
A12C140	281-0775-00		CAP.,FXD,CER DI:0.1UF,20%,50V	72982	8005D9AABZ5U104M
A12C141	283-0175-00		CAP.,FXD,CER DI:10PF,5%,200V	72982	8101B210C0G0100J
A12C142	283-0201-00		CAP.,FXD,CER DI:27PF,10%,200V	72982	8101B210X7R0270K
A12C144	281-0775-00		CAP.,FXD,CER DI:0.1UF,20%,50V	72982	8005D9AABZ5U104M
A12C204	281-0078-00		CAP.,VAR,AIR DI:1.4-7.3PF,750V	74970	189-0503-075
A12C205	281-0214-00		CAP.,VAR,CER DI:0.5-3PF,400V	80031	2502AOR503VP02F0
A12C207	283-0154-00		CAP.,FXD,CER DI:22PF,5%,50V	72982	8111B061COG220J
A12C210	281-0078-00		CAP.,VAR,AIR DI:1.4-7.3PF,750V	74970	189-0503-075
A12C211	281-0214-00		CAP.,VAR,CER DI:0.5-3PF,400V	80031	2502AOR503VP02F0
A12C212	283-0108-00		CAP.,FXD,CER DI:220PF,10%,200V	56289	272C13
A12C219	283-0158-00		CAP.,FXD,CER DI:1PF,10%,50V	72982	8101B057COK0109B
A12C221	283-0000-00		CAP.,FXD,CER DI:0.001UF,+100-0%,500V	59660	831-519-Z5U-102P
A12C225	283-0330-00		CAP.,FXD,CER DI:100PF,5%,50V	51642	150-050-NP0-101J
A12C232	290-0808-00		CAP.,FXD,ELCTLT:2.7UF,10%,20V	56289	162D275X9020CD2
A12C233	283-0000-00		CAP.,FXD,CER DI:0.001UF,+100-0%,500V	59660	831-519-Z5U-102P
A12C234	283-0000-00		CAP.,FXD,CER DI:0.001UF,+100-0%,500V	59660	831-519-Z5U-102P
A12C236	283-0220-00		CAP.,FXD,CER DI:0.01UF,20%,50V	72982	8121N075X7R0103M
A12C237	283-0220-00		CAP.,FXD,CER DI:0.01UF,20%,50V	72982	8121N075X7R0103M
A12C239	283-0160-00		CAP.,FXD,CER DI:1.5PF,10%,50V	72982	8101A058COK159B
A12C241	283-0175-00		CAP.,FXD,CER DI:10PF,5%,200V	72982	8101B210C0G0100J
A12C242	283-0201-00		CAP.,FXD,CER DI:27PF,10%,200V	72982	8101B210X7R0270K
A12C244	281-0775-00		CAP.,FXD,CER DI:0.1UF,20%,50V	72982	8005D9AABZ5U104M
A12C625	283-0631-00		CAP.,FXD,MICA D:95PF,1%,100V	00853	D151E950F0
A12C626	281-0202-00		CAP.,VAR,PLSTC:1.5-5.5PF,100V	80031	2807C1R406MM02F
A12C628A,B,C,D	295-0194-00		CAP SET,MATCHED:2 EA 1.0UF,1.5%,50V	90201	TTX 100 + 100
A12C630	281-0811-00		CAP.,FXD,CER DI:10PF,10%,100V	72982	8035D2AADC1G100K
A12C632	283-0158-00		CAP.,FXD,CER DI:1PF,10%,50V	72982	8101B057COK0109B
A12C636	283-0024-00		CAP.,FXD,CER DI:0.1UF,+80-20%,50V	72982	8121N083Z5U104Z
A12C675	283-0631-00		CAP.,FXD,MICA D:95PF,1%,100V	00853	D151E950F0
A12C676	281-0202-00		CAP.,VAR,PLSTC:1.5-5.5PF,100V	80031	2807C1R406MM02F
A12C677	281-0775-00		CAP.,FXD,CER DI:0.1UF,20%,50V	72982	8005D9AABZ5U104M
A12C679	281-0775-00		CAP.,FXD,CER DI:0.1UF,20%,50V	72982	8005D9AABZ5U104M
A12C680	281-0811-00		CAP.,FXD,CER DI:10PF,10%,100V	72982	8035D2AADC1G100K
A12C720	281-0763-00		CAP.,FXD,CER DI:47PF,10%,100V	72982	8035D9AADC1G470K
A12C732	281-0756-00		CAP.,FXD,CER DI:2.2PF,0.5%,200V	12969	CGB2R2DFN
A12C734	281-0151-00		CAP.,VAR,CER DI:1-3PF,100V	72982	518-600A1-3
A12C736	281-0756-00		CAP.,FXD,CER DI:2.2PF,0.5%,200V	12969	CGB2R2DFN
A12C738	283-0023-00		CAP.,FXD,CER DI:0.1UF,+80-20%,12V	91418	MX0104Z1205R5
A12C741	283-0023-00		CAP.,FXD,CER DI:0.1UF,+80-20%,12V	91418	MX0104Z1205R5
A12CR119	152-0246-00		SEMICONV DEVICE:SW,SI,40V,200MA	03508	DE140

Component No.	Tektronix Part No.	Serial/Model No. Eff Dscont	Name & Description	Mfr Code	Mfr Part Number
A12CR219	152-0246-00		SEMICON D DEVICE:SW,SI,40V,200MA	03508	DE140
A12CR626	152-0245-00		SEMICON D DEVICE:SILICON,10NA AT 5V	80009	152-0245-00
A12CR630	152-0141-02		SEMICON D DEVICE:SILICON,30V,150MA	01295	1N4152R
A12CR676	152-0245-00		SEMICON D DEVICE:SILICON,10NA AT 5V	80009	152-0245-00
A12CR680	152-0141-02		SEMICON D DEVICE:SILICON,30V,150MA	01295	1N4152R
A12P1010	131-0608-00		TERMINAL,PIN:0.365 L X 0.025 PH BRZ GOLD (QTY 4)	22526	47357
A12P2000	136-0328-02		SOCKET,PIN TERM:HORIZONTAL (QTY OF 10)	00779	86282-2
A12P2010	131-0608-00		TERMINAL,PIN:0.365 L X 0.025 PH BRZ GOLD (QTY 4)	22526	47357
A12P6000	131-0608-00		TERMINAL,PIN:0.365 L X 0.025 PH BRZ GOLD (QTY 10)	22526	47357
A12P7000	131-0608-00		TERMINAL,PIN:0.365 L X 0.025 PH BRZ GOLD (QTY 7)	22526	47357
A12Q122	151-1124-00		TRANSISTOR:JFE,N-CHAN,SI,SEL	22229	F2942
A12Q125	151-0711-00		TRANSISTOR:SILICON,NPN	04713	SPS8224
A12Q133	151-0711-00		TRANSISTOR:SILICON,NPN	04713	SPS8224
A12Q134	151-0712-00		TRANSISTOR:SILICON,NPN	04713	SPS8223
A12Q139	151-0216-00		TRANSISTOR:SILICON,PNP	04713	SPS8803
A12Q222	151-1124-00		TRANSISTOR:JFE,N-CHAN,SI,SEL	22229	F2942
A12Q225	151-0711-00		TRANSISTOR:SILICON,NPN	04713	SPS8224
A12Q233	151-0711-00		TRANSISTOR:SILICON,NPN	04713	SPS8224
A12Q234	151-0712-00		TRANSISTOR:SILICON,NPN	04713	SPS8223
A12Q239	151-0216-00		TRANSISTOR:SILICON,PNP	04713	SPS8803
A12Q629	151-0188-00		TRANSISTOR:SILICON,PNP	04713	SPS6868K
A12Q630A,B	151-1042-00		SEMICON D VC SE:MATCHED PAIR FET	27014	SF50031
A12Q631	151-0190-00		TRANSISTOR:SILICON,NPN	07263	S032677
A12Q634	151-0736-00		TRANSISTOR:SILICON,NPN	04713	SPS8317
A12Q680A,B	151-1042-00		SEMICON D VC SE:MATCHED PAIR FET	27014	SF50031
A12Q681	151-0190-00		TRANSISTOR:SILICON,NPN	07263	S032677
A12Q684	151-0736-00		TRANSISTOR:SILICON,NPN	04713	SPS8317
A12Q720	151-0190-00		TRANSISTOR:SILICON,NPN	07263	S032677
A12Q730	151-0712-00		TRANSISTOR:SILICON,NPN	04713	SPS8223
A12Q731	151-0712-00		TRANSISTOR:SILICON,NPN	04713	SPS8223
A12Q736	151-0711-00		TRANSISTOR:SILICON,NPN	04713	SPS8224
A12R103	315-0240-00		RES.,FXD,CMPSN:24 OHM,5%,0.25W	01121	CB2405
A12R105	321-0807-01		RES.,FXD,FILM:900K OHM,0.5%,0.125W	91637	MFF1816G90002D
A12R106	317-0330-00		RES.,FXD,CMPSN:33 OHM,5%,0.125W	01121	BB3305
A12R107	321-1389-01		RES.,FXD,FILM:111K OHM,0.5%,0.125W	91637	MFF1816G11102D
A12R108	315-0620-00		RES.,FXD,CMPSN:62 OHM,5%,0.25W	01121	CB6205
A12R110	315-0101-00		RES.,FXD,CMPSN:100 OHM,5%,0.25W	01121	CB1015
A12R111	321-0790-01		RES.,FXD,FILM:990K OHM,0.5%,0.125W	91637	HFF1104C99002D
A12R112	315-0120-00		RES.,FXD,CMPSN:12 OHM,5%,0.25W	01121	CB1205
A12R114	321-1289-01		RES.,FXD,FILM:10.1K OHM,0.5%,0.125W	91637	MFF1816G10101D
A12R115	315-0910-00		RES.,FXD,CMPSN:91 OHM,5%,0.25W	01121	CB9105
A12R116	321-0385-04		RES.,FXD,FILM:100K OHM,0.1%,0.125W	91637	MFF1816D10002B
A12R117	321-0807-04		RES.,FXD,FILM:900K OHM,0.1%,0.125W	24546	NC55C9003B
A12R119	315-0107-00		RES.,FXD,CMPSN:100M OHM,5%,0.25W	01121	CB1075
A12R120	315-0104-00		RES.,FXD,CMPSN:100K OHM,5%,0.25W	01121	CB1045
A12R121	315-0435-00		RES.,FXD,CMPSN:4.3M OHM,5%,0.25W	01121	CB4355
A12R122	301-0122-00		RES.,FXD,CMPSN:1.2K OHM,5%,0.50W	01121	EB1225
A12R123	315-0100-00		RES.,FXD,CMPSN:10 OHM,5%,0.25W	01121	CB1005
A12R124	315-0102-00		RES.,FXD,CMPSN:1K OHM,5%,0.25W	01121	CB1025
A12R125	321-0131-00		RES.,FXD,FILM:226 OHM,1%,0.125W	91637	MFF1816G226R0F
A12R126	321-0126-00		RES.,FXD,FILM:200 OHM,1%,0.125W	91637	MFF1816G200R0F
A12R127	315-0470-00		RES.,FXD,CMPSN:47 OHM,5%,0.25W	01121	CB4705

Replaceable Electrical Parts—2215 Service

Component No.	Tektronix Part No.	Serial/Model No. Eff Dscont	Name & Description	Mfr Code	Mfr Part Number
A12R128	315-0102-00		RES.,FXD,CMPSN:1K OHM,5%,0.25W	01121	CB1025
A12R130	315-0182-00		RES.,FXD,CMPSN:1.8K OHM,5%,0.25W	01121	CB1825
A12R131	321-0254-00		RES.,FXD,FILM:4.32K OHM,1%,0.125W	91637	MFF1816G43200F
A12R132	321-0229-00		RES.,FXD,FILM:2.37K OHM,1%,0.125W	91637	MFF1816G23700F
A12R133	315-0101-00		RES.,FXD,CMPSN:100 OHM,5%,0.25W	01121	CB1015
A12R134	315-0680-00		RES.,FXD,CMPSN:68 OHM,5%,0.25W	01121	CB6805
A12R135	315-0472-00		RES.,FXD,CMPSN:4.7K OHM,5%,0.25W	01121	CB4725
A12R136	307-0106-00		RES.,FXD,CMPSN:4.7 OHM,5%,0.25W	01121	CB47G5
A12R137	315-0100-00		RES.,FXD,CMPSN:10 OHM,5%,0.25W	01121	CB1005
A12R138	311-1559-00		RES.,VAR,NONWIR:10K OHM,20%,0.50W	73138	91-81-0
A12R139	307-0710-00		RES NTWK,FXD,FI:ATTENUATOR	80009	307-0710-00
A12R140	315-0132-00		RES.,FXD,CMPSN:1.3K OHM,5%,0.25W	01121	CB1325
A12R141	311-2133-00		RES.,VAR,NONWIR:PNL,500 OHM,20%,0.50W	W12697	CM41766
A12R142	315-0304-00		RES.,FXD,CMPSN:300K OHM,5%,0.25W	01121	CB3045
A12R143	315-0301-00		RES.,FXD,CMPSN:300 OHM,5%,0.25W	01121	CB3015
A12R144	315-0111-00		RES.,FXD,CMPSN:110 OHM,5%,0.25W	01121	CB1115
A12R145	311-1562-00		RES.,VAR,NONWIR:2K OHM,20%,0.50W	73138	91-84-0
A12R146	311-0607-00		RES.,VAR,NONWIR:10K OHM,10%,0.50W	73138	82-25-2
A12R147	315-0393-00		RES.,FXD,CMPSN:39K OHM,5%,0.25W	01121	CB3935
A12R148	315-0111-00		RES.,FXD,CMPSN:110 OHM,5%,0.25W	01121	CB1115
A12R149	315-0101-00		RES.,FXD,CMPSN:100 OHM,5%,0.25W	01121	CB1015
A12R203	315-0240-00		RES.,FXD,CMPSN:24 OHM,5%,0.25W	01121	CB2405
A12R205	321-0807-01		RES.,FXD,FILM:900K OHM,0.5%,0.125W	91637	MFF1816G90002D
A12R206	317-0330-00		RES.,FXD,CMPSN:33 OHM,5%,0.125W	01121	BB3305
A12R207	321-1389-01		RES.,FXD,FILM:111K OHM,0.5%,0.125W	91637	MFF1816G11102D
A12R208	315-0620-00		RES.,FXD,CMPSN:62 OHM,5%,0.25W	01121	CB6205
A12R210	315-0101-00		RES.,FXD,CMPSN:100 OHM,5%,0.25W	01121	CB1015
A12R211	321-0790-01		RES.,FXD,FILM:990K OHM,0.5%,0.125W	91637	HFF1104G99002D
A12R212	315-0120-00		RES.,FXD,CMPSN:12 OHM,5%,0.25W	01121	CB1205
A12R214	321-1289-01		RES.,FXD,FILM:10.1K OHM,0.5%,0.125W	91637	MFF1816G10101D
A12R215	315-0910-00		RES.,FXD,CMPSN:91 OHM,5%,0.25W	01121	CB9105
A12R216	321-0385-04		RES.,FXD,FILM:100K OHM,0.1%,0.125W	91637	MFF1816D10002B
A12R217	321-0807-04		RES.,FXD,FILM:900K OHM,0.1%,0.125W	24546	NC55C9003B
A12R219	315-0107-00		RES.,FXD,CMPSN:100M OHM,5%,0.25W	01121	CB1075
A12R220	315-0104-00		RES.,FXD,CMPSN:100K OHM,5%,0.25W	01121	CB1045
A12R221	315-0435-00		RES.,FXD,CMPSN:4.3M OHM,5%,0.25W	01121	CB4355
A12R222	301-0122-00		RES.,FXD,CMPSN:1.2K OHM,5%,0.50W	01121	EB1225
A12R225	321-0131-00		RES.,FXD,FILM:226 OHM,1%,0.125W	91637	MFF1816G226R0F
A12R226	321-0126-00		RES.,FXD,FILM:200 OHM,1%,0.125W	91637	MFF1816G200R0F
A12R227	315-0470-00		RES.,FXD,CMPSN:47 OHM,5%,0.25W	01121	CB4705
A12R231	321-0254-00		RES.,FXD,FILM:4.32K OHM,1%,0.125W	91637	MFF1816G43200F
A12R232	321-0229-00		RES.,FXD,FILM:2.37K OHM,1%,0.125W	91637	MFF1816G23700F
A12R233	315-0101-00		RES.,FXD,CMPSN:100 OHM,5%,0.25W	01121	CB1015
A12R234	315-0680-00		RES.,FXD,CMPSN:68 OHM,5%,0.25W	01121	CB6805
A12R235	315-0472-00		RES.,FXD,CMPSN:4.7K OHM,5%,0.25W	01121	CB4725
A12R236	307-0106-00		RES.,FXD,CMPSN:4.7 OHM,5%,0.25W	01121	CB47G5
A12R237	315-0100-00		RES.,FXD,CMPSN:10 OHM,5%,0.25W	01121	CB1005
A12R238	311-1559-00		RES.,VAR,NONWIR:10K OHM,20%,0.50W	73138	91-81-0
A12R239	307-0710-00		RES NTWK,FXD,FI:ATTENUATOR	80009	307-0710-00
A12R240	315-0132-00		RES.,FXD,CMPSN:1.3K OHM,5%,0.25W	01121	CB1325
A12R241	311-2133-00		RES.,VAR,NONWIR:PNL,500 OHM,20%,0.50W	W12697	CM41766
A12R242	315-0304-00		RES.,FXD,CMPSN:300K OHM,5%,0.25W	01121	CB3045
A12R243	315-0301-00		RES.,FXD,CMPSN:300 OHM,5%,0.25W	01121	CB3015
A12R244	315-0111-00		RES.,FXD,CMPSN:110 OHM,5%,0.25W	01121	CB1115
A12R245	311-0609-00		RES.,VAR,NONWIR:2K OHM,10%,0.50W	73138	82-26-1
A12R246	311-0607-00		RES.,VAR,NONWIR:10K OHM,10%,0.50W	73138	82-25-2
A12R247	315-0393-00		RES.,FXD,CMPSN:39K OHM,5%,0.25W	01121	CB3935

Component No.	Tektronix Part No.	Serial/Model No. Eff Dscont	Name & Description	Mfr Code	Mfr Part Number
A12R248	315-0111-00		RES., FXD, CMPSN: 110 OHM, 5%, 0.25W	01121	CB1115
A12R249	315-0101-00		RES., FXD, CMPSN: 100 OHM, 5%, 0.25W	01121	CB1015
A12R625	322-0519-01		RES., FXD, FILM: 2.49M OHM, 0.5%, 0.25W	91637	HFF143G24903D
A12R626	307-0780-00		RES NTWK, FXD, FI: TIMING	80009	307-0780-00
A12R627	315-0241-00		RES., FXD, CMPSN: 240 OHM, 5%, 0.25W	01121	CB2415
A12R628	315-0100-00		RES., FXD, CMPSN: 10 OHM, 5%, 0.25W	01121	CB1005
A12R629	311-2151-00		RES., VAR, NONWIR: PNL, 500 OHM, 20%, 0.5W, DPST	12697	OBD
	-----		(PART OF S734)		
A12R630	315-0510-00		RES., FXD, CMPSN: 51 OHM, 5%, 0.25W	01121	CB5105
A12R631	301-0242-00		RES., FXD, CMPSN: 2.4K OHM, 5%, 0.50W	01121	EB2425
A12R632	315-0114-00		RES., FXD, CMPSN: 110K OHM, 5%, 0.25W	01121	CB1145
A12R633	321-0232-00		RES., FXD, FILM: 2.55K OHM, 1%, 0.125W	91637	MFF1816G25500F
A12R634	321-0232-00		RES., FXD, FILM: 2.55K OHM, 1%, 0.125W	91637	MFF1816G25500F
A12R635	315-0102-00		RES., FXD, CMPSN: 1K OHM, 5%, 0.25W	01121	CB1025
A12R636	307-0107-00		RES., FXD, CMPSN: 5.6 OHM, 5%, 0.25W	01121	CB56G5
A12R676	307-0780-00		RES NTWK, FXD, FI: TIMING	80009	307-0780-00
A12R677	307-0107-00		RES., FXD, CMPSN: 5.6 OHM, 5%, 0.25W	01121	CB56G5
A12R678	315-0100-00		RES., FXD, CMPSN: 10 OHM, 5%, 0.25W	01121	CB1005
A12R679	307-0107-00		RES., FXD, CMPSN: 5.6 OHM, 5%, 0.25W	01121	CB56G5
A12R680	315-0510-00		RES., FXD, CMPSN: 51 OHM, 5%, 0.25W	01121	CB5105
A12R681	301-0242-00		RES., FXD, CMPSN: 2.4K OHM, 5%, 0.50W	01121	EB2425
A12R682	311-1248-00		RES., VAR, NONWIR: 500 OHM, 10%, 0.50W	73138	72-23-0
A12R683	321-0228-00		RES., FXD, FILM: 2.32K OHM, 1%, 0.125W	91637	MFF1816G23200F
A12R684	321-0232-00		RES., FXD, FILM: 2.55K OHM, 1%, 0.125W	91637	MFF1816G25500F
A12R685	315-0102-00		RES., FXD, CMPSN: 1K OHM, 5%, 0.25W	01121	CB1025
A12R686	315-0682-00		RES., FXD, CMPSN: 6.8K OHM, 5%, 0.25W	01121	CB6825
A12R691	315-0470-00		RES., FXD, CMPSN: 47 OHM, 5%, 0.25W	01121	CB4705
A12R720	315-0221-00		RES., FXD, CMPSN: 220 OHM, 5%, 0.25W	01121	CB2215
A12R721	315-0101-00		RES., FXD, CMPSN: 100 OHM, 5%, 0.25W	01121	CB1015
A12R722	315-0152-00		RES., FXD, CMPSN: 1.5K OHM, 5%, 0.25W	01121	CB1525
A12R723	315-0682-00		RES., FXD, CMPSN: 6.8K OHM, 5%, 0.25W	01121	CB6825
A12R724	315-0392-00		RES., FXD, CMPSN: 3.9K OHM, 5%, 0.25W	01121	CB3925
A12R725	315-0822-00		RES., FXD, CMPSN: 8.2K OHM, 5%, 0.25W	01121	CB8225
A12R728	315-0822-00		RES., FXD, CMPSN: 8.2K OHM, 5%, 0.25W	01121	CB8225
A12R729	321-0159-00		RES., FXD, FILM: 442 OHM, 1%, 0.125W	91637	MFF1816G442R0F
A12R730	315-0561-00		RES., FXD, CMPSN: 560 OHM, 5%, 0.25W	01121	CB5615
A12R731	315-0911-00		RES., FXD, CMPSN: 910 OHM, 5%, 0.25W	01121	CB9115
A12R732	321-0206-00		RES., FXD, FILM: 1.37K OHM, 1%, 0.125W	91637	MFF1816G13700F
A12R733	311-1562-00		RES., VAR, NONWIR: 2K OHM, 20%, 0.50W	73138	91-84-0
A12R734	321-0295-00		RES., FXD, FILM: 11.5K OHM, 1%, 0.125W	91637	MFF1816G11501F
A12R736	315-0272-00		RES., FXD, CMPSN: 2.7K OHM, 5%, 0.25W	01121	CB2725
A12R737	315-0362-00		RES., FXD, CMPSN: 3.6K OHM, 5%, 0.25W	01121	CB3625
A12R738	315-0100-00		RES., FXD, CMPSN: 10 OHM, 5%, 0.25W	01121	CB1005
A12R739	315-0560-00		RES., FXD, CMPSN: 56 OHM, 5%, 0.25W	01121	CB5605
A12R741	315-0100-00		RES., FXD, CMPSN: 10 OHM, 5%, 0.25W	01121	CB1005
A12RT144	307-0125-00		RES., THERMAL: 500 OHM, 10%, 25 DEG C	50157	2D1595
A12RT244	307-0125-00		RES., THERMAL: 500 OHM, 10%, 25 DEG C	50157	2D1595
A12S734	-----		(PART OF R629)		
A12S105A, B	260-2025-00		SWITCH, ROTARY: VERTICAL ATTENUATOR	80009	260-2025-00
A12S205A, B	260-2025-00		SWITCH, ROTARY: VERTICAL ATTENUATOR	80009	260-2025-00
A12S630A, B, C	260-2023-00		SWITCH, ROTARY: TIME/DIV A/B	80009	260-2023-00
A12U120	156-1551-00		MICROCIRCUIT, LI: OPNL. AMPL.	02735	90593
A12U145	155-0227-00		MICROCIRCUIT, LI: VERTICAL. PREAMP	80009	155-0227-00
A12U220	156-1551-00		MICROCIRCUIT, LI: OPNL. AMPL.	02735	90593
A12U245	155-0227-00		MICROCIRCUIT, LI: VERTICAL. PREAMP	80009	155-0227-00
A12VR122	152-0168-00		SEMICOND DEVICE: ZENER, 0.4W, 12V, 5%	04713	S2G3009K4
A12VR130	152-0217-00		SEMICOND DEVICE: ZENER, 0.4W, 8.2V, 5%	04713	S2G30

**Replaceable Electrical Parts—2215 Service**

Component No.	Tektronix Part No.	Serial/Model No. Eff Dscont	Name & Description	Mfr Code	Mfr Part Number
A12VR222	152-0168-00		SEMICOND DEVICE:ZENER,0.4W,12V,5%	04713	SZG35009K4
A12VR629	152-0647-00		SEMICOND DEVICE:ZENER,0.4W,6.8V,5%	80009	152-0647-00
A12W116	131-0566-00		BUS CONDUCTOR:DUMMY RES,2.375,22 AWG	55210	L-2007-1



Component No.	Tektronix Part No.	Serial/Model No. Eff Dscont	Name & Description	Mfr Code	Mfr Part Number
A13	-----		CKT BOARD ASSY:ALTERNATE SWEEP		
A13C554	281-0862-00		CAP.,FXD,CER DI:0.001UF,+80-20%,100V	20932	401-ES-100-AD102
A13C556	281-0773-00		CAP.,FXD,CER DI:0.01UF,10%,100V	04222	GC70-1C103K
A13C566	281-0615-00		CAP.,FXD,CER DI:3.9PF,+/-0.5PF,200V	59660	374001C0J0399D
A13C584	281-0773-00		CAP.,FXD,CER DI:0.01UF,10%,100V	04222	GC70-1C103K
A13C585	281-0775-00		CAP.,FXD,CER DI:0.1UF,20%,50V	72982	8005D9AABZ5U104M
A13C657	281-0615-00		CAP.,FXD,CER DI:3.9PF,+/-0.5PF,200V	59660	374001C0J0399D
A13C659	290-0776-00	XB010685	CAP.,FXD,ELCTLT:22UF,+50-10%,10V	55680	10ULA22V-T
A13C664	281-0786-00		CAP.,FXD,CER DI:150PF,10%,100V	72982	8035D2AADX5P151K
A13C690	281-0770-00		CAP.,FXD,CER DI:0.001UF,20%,100V	72982	8035D9AADX5R102M
A13C693	281-0775-00		CAP.,FXD,CER DI:0.1UF,20%,50V	72982	8005D9AABZ5U104M
A13CR662	152-0141-02		SEMICONV DEVICE:SILICON,30V,150MA	01295	1N4152R
A13CR669	152-0141-02		SEMICONV DEVICE:SILICON,30V,150MA	01295	1N4152R
A13CR670	152-0141-02		SEMICONV DEVICE:SILICON,30V,150MA	01295	1N4152R
A13CR671	152-0141-02		SEMICONV DEVICE:SILICON,30V,150MA	01295	1N4152R
A13CR672	152-0141-02		SEMICONV DEVICE:SILICON,30V,150MA	01295	1N4152R
A13Q573	151-0435-00		TRANSISTOR:SILICON,PNP	04713	SPS8335
A13Q592	151-0199-00		TRANSISTOR:SILICON,PNP	04713	SPS6866K
A13Q593	151-0199-00		TRANSISTOR:SILICON,PNP	04713	SPS6866K
A13Q662	151-0190-00		TRANSISTOR:SILICON,NPN	07263	S032677
A13Q664	151-0190-00		TRANSISTOR:SILICON,NPN	07263	S032677
A13Q690	151-0190-00		TRANSISTOR:SILICON,NPN	07263	S032677
A13R552	315-0510-00		RES.,FXD,CMPSN:51 OHM,5%,0.25W	01121	CB5105
A13R553	315-0472-00		RES.,FXD,CMPSN:4.7K OHM,5%,0.25W	01121	CB4725
A13R554	315-0391-00		RES.,FXD,CMPSN:390 OHM,5%,0.25W	01121	CB3915
A13R555	315-0302-00		RES.,FXD,CMPSN:3K OHM,5%,0.25W	01121	CB3025
A13R556	315-0100-00		RES.,FXD,CMPSN:10 OHM,5%,0.25W	01121	CB1005
A13R560	321-0207-00		RES.,FXD,FILM:1.4K OHM,1%,0.125W	91637	MFF1816G14000F
A13R561	321-0197-00		RES.,FXD,FILM:1.1K OHM,1%,0.125W	91637	MFF1816G11000F
A13R562	321-0203-00		RES.,FXD,FILM:1.27K OHM,1%,0.125W	91637	MFF1816G12700F
A13R563	321-0201-00		RES.,FXD,FILM:1.21K OHM,1%,0.125W	91637	MFF1816G12100F
A13R564	315-0242-00		RES.,FXD,CMPSN:2.4K OHM,5%,0.25W	01121	CB2425
A13R566	315-0101-00		RES.,FXD,CMPSN:100 OHM,5%,0.25W	01121	CB1015
A13R567	315-0821-00		RES.,FXD,CMPSN:820 OHM,5%,0.25W	01121	CB8215
A13R569	315-0123-00		RES.,FXD,CMPSN:12K OHM,5%,0.25W	01121	CB1235
A13R571	315-0104-00		RES.,FXD,CMPSN:100K OHM,5%,0.25W	01121	CB1045
A13R573	315-0102-00		RES.,FXD,CMPSN:1K OHM,5%,0.25W	01121	CB1025
A13R574	315-0185-00		RES.,FXD,CMPSN:1.8M OHM,5%,0.25W	01121	CB1855
A13R575	315-0512-00		RES.,FXD,CMPSN:5.1K OHM,5%,0.25W	01121	CB5125
A13R579	315-0511-00		RES.,FXD,CMPSN:510 OHM,5%,0.25W	01121	CB5115
A13R581	321-0191-00		RES.,FXD,FILM:953 OHM,1%,0.125W	91637	MFF1816G953R0F
A13R582	315-0820-00		RES.,FXD,CMPSN:82 OHM,5%,0.25W	01121	CB8205
A13R584	301-0470-00		RES.,FXD,CMPSN:47 OHM,5%,0.50W	01121	EB4705
A13R585	315-0511-00		RES.,FXD,CMPSN:510 OHM,5%,0.25W	01121	CB5115
A13R587	315-0511-00		RES.,FXD,CMPSN:510 OHM,5%,0.25W	01121	CB5115
A13R590	315-0511-00		RES.,FXD,CMPSN:510 OHM,5%,0.25W	01121	CB5115
A13R591	315-0361-00		RES.,FXD,CMPSN:360 OHM,5%,0.25W	01121	CB3615
A13R593	315-0242-00		RES.,FXD,CMPSN:2.4K OHM,5%,0.25W	01121	CB2425
A13R594	315-0361-00		RES.,FXD,CMPSN:360 OHM,5%,0.25W	01121	CB3615
A13R641	315-0102-00		RES.,FXD,CMPSN:1K OHM,5%,0.25W	01121	CB1025
A13R644	315-0752-00	B010100 B010684	RES.,FXD,CMPSN:7.5K OHM,5%,0.25W	01121	CB7525
A13R644	315-0102-00	B010685	RES.,FXD,CMPSN:1K OHM,5%,0.25W	01121	CB1025
A13R648	315-0331-00		RES.,FXD,CMPSN:330 OHM,5%,0.25W	01121	CB3315
A13R650	315-0392-00		RES.,FXD,CMPSN:3.9K OHM,5%,0.25W	01121	CB3925
A13R652	315-0162-00		RES.,FXD,CMPSN:1.6K OHM,5%,0.25W	01121	CB1625
A13R653	321-0271-00		RES.,FXD,FILM:6.49K OHM,1%,0.125W	91637	MFF1816G64900F
A13R654	311-1238-00		RES.,VAR,NONWTR:5K OHM,10%,0.50W	73138	72-27-0

Replaceable Electrical Parts—2215 Service

Component No.	Tektronix Part No.	Serial/Model No. Eff Dscont	Name & Description	Mfr Code	Mfr Part Number
A13R655	321-0304-00		RES., FXD, FILM: 14.3K OHM, 1%, 0.125W	91637	MFF1816G14301F
A13R656	315-0332-00		RES., FXD, CMPSN: 3.3K OHM, 5%, 0.25W	01121	CB3325
A13R657	315-0473-00		RES., FXD, CMPSN: 47K OHM, 5%, 0.25W	01121	CB4735
A13R660	315-0471-00		RES., FXD, CMPSN: 470 OHM, 5%, 0.25W	01121	CB4715
A13R661	321-0307-00		RES., FXD, FILM: 15.4K OHM, 1%, 0.125W	91637	MFF1816G15401F
A13R662	315-0162-00		RES., FXD, CMPSN: 1.6K OHM, 5%, 0.25W	01121	CB1625
A13R663	315-0102-00		RES., FXD, CMPSN: 1K OHM, 5%, 0.25W	01121	CB1025
A13R664	315-0392-00		RES., FXD, CMPSN: 3.9K OHM, 5%, 0.25W	01121	CB3925
A13R665	315-0392-00		RES., FXD, CMPSN: 3.9K OHM, 5%, 0.25W	01121	CB3925
A13R667	315-0622-00		RES., FXD, CMPSN: 6.2K OHM, 5%, 0.25W	01121	CB6225
A13R669	315-0102-00		RES., FXD, CMPSN: 1K OHM, 5%, 0.25W	01121	CB1025
A13R671	315-0302-00		RES., FXD, CMPSN: 3K OHM, 5%, 0.25W	01121	CB3025
A13R672	315-0302-00		RES., FXD, CMPSN: 3K OHM, 5%, 0.25W	01121	CB3025
A13R675	315-0102-00		RES., FXD, CMPSN: 1K OHM, 5%, 0.25W	01121	CB1025
A13R687	321-0322-00		RES., FXD, FILM: 22.1K OHM, 1%, 0.125W	91637	MFF1816G22101F
A13R688	321-0319-00		RES., FXD, FILM: 20.5K OHM, 1%, 0.125W	91637	MFF1816G20501F
A13R689	315-0153-00		RES., FXD, CMPSN: 15K OHM, 5%, 0.25W	01121	CB1535
A13R690	315-0512-00		RES., FXD, CMPSN: 5.1K OHM, 5%, 0.25W	01121	CB5125
A13R693	315-0512-00		RES., FXD, CMPSN: 5.1K OHM, 5%, 0.25W	01121	CB5125
A13R694	315-0512-00		RES., FXD, CMPSN: 5.1K OHM, 5%, 0.25W	01121	CB5125
A13R695	315-0512-00		RES., FXD, CMPSN: 5.1K OHM, 5%, 0.25W	01121	CB5125
A13R696	315-0621-00		RES., FXD, CMPSN: 620 OHM, 5%, 0.25W	01121	CB6215
A13R697	315-0621-00		RES., FXD, CMPSN: 620 OHM, 5%, 0.25W	01121	CB6215
A13U555	156-1349-00		MICROCIRCUIT, LI: DUAL INDEP DIFF AMPL	80009	156-1349-00
A13U585	156-0205-00		MICROCIRCUIT, DI: QUAD 2-INPUT NOR GATE	04713	MC10102 (P OR L)
A13U648	156-1381-00		MICROCIRCUIT, LI: XSTR ARRAY	02735	CA3096AE-17
A13U665	156-0382-00		MICROCIRCUIT, DI: QUAD 2-INPUT NAND GATE	01295	SN74LS00(N OR J)
A13U670	156-0382-00		MICROCIRCUIT, DI: QUAD 2-INPUT NAND GATE	01295	SN74LS00(N OR J)
A13U690	156-0385-00		MICROCIRCUIT, DI: HEX. INVERTER	80009	156-0385-00
A13U693	156-0480-00	B010100 B012542	MICROCIRCUIT, DI: QUAD 2-INPUT AND GATE	01295	SN74LS08(N OR J)
A13U693	156-0480-02	B012543	MICROCIRCUIT, DI: QUAD 2 INP & GATE	01295	SN74LS08NP3
A13U696	156-1611-00		MICROCIRCUIT, DI: DUAL D TYPE EDGE-TRIGGERED	07263	74F74
A13VR584	152-0195-00	B010100 B012542	SEMICONV DEVICE: ZENER, 0.4W, 5.1V, 5%	04713	SZ11755
A13VR584	152-0662-00	B012543	SEMICONV DEVICE: ZENER, 0.4W, 5V, 1%	04713	SZG195
A13W556	131-0566-00		BUS CONDUCTOR: DUMMY RES, 2.375, 22 AWG	55210	L-2007-1
A13W661	131-0566-00		BUS CONDUCTOR: DUMMY RES, 2.375, 22 AWG	55210	L-2007-1
A13W662	131-0566-00		BUS CONDUCTOR: DUMMY RES, 2.375, 22 AWG	55210	L-2007-1
A13W665	131-0566-00		BUS CONDUCTOR: DUMMY RES, 2.375, 22 AWG	55210	L-2007-1
A13W670	131-0566-00		BUS CONDUCTOR: DUMMY RES, 2.375, 22 AWG	55210	L-2007-1
A13W671	131-0566-00		BUS CONDUCTOR: DUMMY RES, 2.375, 22 AWG	55210	L-2007-1
A13W672	131-0566-00		BUS CONDUCTOR: DUMMY RES, 2.375, 22 AWG	55210	L-2007-1
A13W689	131-0566-00		BUS CONDUCTOR: DUMMY RES, 2.375, 22 AWG	55210	L-2007-1
A13W690	131-0566-00		BUS CONDUCTOR: DUMMY RES, 2.375, 22 AWG	55210	L-2007-1
A13W692	131-0566-00		BUS CONDUCTOR: DUMMY RES, 2.375, 22 AWG	55210	L-2007-1
A13W693	131-0566-00		BUS CONDUCTOR: DUMMY RES, 2.375, 22 AWG	55210	L-2007-1
A13W694	131-0566-00		BUS CONDUCTOR: DUMMY RES, 2.375, 22 AWG	55210	L-2007-1
A13W695	131-0566-00		BUS CONDUCTOR: DUMMY RES, 2.375, 22 AWG	55210	L-2007-1
A13W1001	131-0589-00		TERMINAL, PIN: 0.46 L X 0.025 SQ	80009	131-0589-00
	-----		(QTY 27)		

Component No.	Tektronix Part No.	Serial/Model No. Eff	Dscont	Name & Description	Mfr Code	Mfr Part Number
A19	-----			CKT BOARD ASSY:CURRENT LIMIT		
A19C938	285-1222-00			CAP.,FXD,PLSTC:0.068UF,20%,250V	000FG	PME271M568
A19CR932	152-0782-00			SEMICONV DEVICE:RECTIFIER,SILICON,600V	05828	GP20J-009
A19CR934	152-0782-00			SEMICONV DEVICE:RECTIFIER,SILICON,600V	05828	GP20J-009
A19CR935	152-0141-02			SEMICONV DEVICE:SILICON,30V,150MA	01295	1N4152R
A19F937	159-0032-00			FUSE,CARTRIDGE:3AG,0.5A,250V,SLOW-BLOW	71400	MDL 1/2
A19P801	131-1048-00			TERM.QIK DISC:CKT BD MT,0.11 X 0.02	00779	61134-1
A19P802	131-1048-00			TERM.QIK DISC:CKT BD MT,0.11 X 0.02	00779	61134-1
A19P803	131-1048-00			TERM.QIK DISC:CKT BD MT,0.11 X 0.02	00779	61134-1
A19P804	131-1048-00			TERM.QIK DISC:CKT BD MT,0.11 X 0.02	00779	61134-1
A19Q933	151-0736-00			TRANSISTOR:SILICON,NPN	04713	SPS8317
A19Q938	151-1141-00			TRANSISTOR:FE,N-CHANNEL,SI,TO-220	04713	STP3000
A19R933	301-0203-00			RES.,FXD,CMPSN:20K OHM,5%,0.50W	01121	EB2035
A19R935	321-0165-00	B010100	B010435	RES.,FXD,FILM:511 OHM,1%,0.125W	91637	MFF1816G511R0F
A19R935	321-0140-00	B010436		RES.,FXD,FILM:280 OHM,1%,0.125W	91637	MFF1816G280R0F
A19R936	321-0193-00	B010100	B010435	RES.,FXD,FILM:1K OHM,1%,0.125W	91637	MFF1816G10000F
A19R936	321-0152-00	B010436		RES.,FXD,FILM:374 OHM,1%,0.125W	91637	MFF1816G374R0F
A19R937	308-0710-00	B010100	B010435	RES.,FXD,WW:0.27 OHM,10%,1W	75042	BW20-R2700J
A19R937	308-0843-00	B010436		RES.,FXD,WW:0.2 OHM,5%,1.0W	75042	BW20-R2000J
A19R938	301-0203-00			RES.,FXD,CMPSN:20K OHM,5%,0.50W	01121	EB2035
A19R939	308-0123-00			RES.,FXD,WW:20 OHM,5%,5W	05347	C56-20R0J
A19RT935	307-0125-00			RES.,THERMAL:500 OHM,10%,25 DEG C	50157	2D1595
A19VR933	152-0268-00	B010100	B010435	SEMICONV DEVICE:ZENER,0.4W,56V,5%	80009	152-0268-00
A19VR933	152-0286-00	B010436		SEMICONV DEVICE:ZENER,0.4W,75V,5%	80009	152-0286-00
A19VR934	152-0149-00			SEMICONV DEVICE:ZENER,0.4W,10V,5%	04713	SZG35009K3

**Replaceable Electrical Parts—2215 Service**

Component No.	Tektronix Part No.	Serial/Model No. Eff Dscont	Name & Description	Mfr Code	Mfr Part Number
CHASSIS PARTS					
C401	281-0787-00		CAP., FXD, CER DI:15PF, 5%, 500V	72982	0314021COG0150J
DL350	119-1392-00		DELAY LINE, ELEC:100 NANO SEC, 150 OHM	80009	119-1392-00
F901	159-0021-00		FUSE, CARTRIDGE:3AG, 2A, 250V, FAST-BLOW	71400	AGC 2
J1001	131-0126-00		CONNECTOR, RCPT, :BNC, FEMALE	77820	9663-1 NT-34
J2001	131-0126-00		CONNECTOR, RCPT, :BNC, FEMALE	77820	9663-1 NT-34
J4001	131-0955-00		CONN, RCPT, ELEC:BNC, FEMALE	13511	31-279
J8001	131-0955-00		CONN, RCPT, ELEC:BNC, FEMALE	13511	31-279
L925	108-1096-00		COIL, RF:FIXED, 16MH, 25%	54937	5002282
Q938	151-1141-00		TRANSISTOR:FE, N-CHANNEL, SI	81483	94-0109
R647	311-2146-00		RES., VAR, NONWIR:50 OHM, 20%, 0.5W	12697	CM41773
R658	311-1183-00		RES., VAR, WW:2K OHM, 5%, 0.25W	02111	534-9514
V870	154-0838-00		ELECTRON TUBE:CRT, T4652-31-2	80009	154-0838-00

# DIAGRAMS AND CIRCUIT BOARD ILLUSTRATIONS

## Symbols

Graphic symbols and class designation letters are based on ANSI Standard Y32.2-1975.

Logic symbology is based on ANSI Y32.14-1973 in terms of positive logic. Logic symbols depict the logic function performed and may differ from the manufacturer's data.

The overline on a signal name indicates that the signal performs its intended function when it is in the low state.

Abbreviations are based on ANSI Y1.1-1972.

Other ANSI standards that are used in the preparation of diagrams by Tektronix, Inc. are:

Y14.15, 1966 Drafting Practices.  
 Y14.2, 1973 Line Conventions and Lettering.  
 Y10.5, 1968 Letter Symbols for Quantities Used in Electrical Science and Electrical Engineering.

American National Standard Institute  
 1430 Broadway  
 New York, New York 10018

## Component Values

Electrical components shown on the diagrams are in the following units unless noted otherwise:

Capacitors = Values one or greater are in picofarads (pF).  
 Values less than one are in microfarads ( $\mu$ F).  
 Resistors = Ohms ( $\Omega$ ).

The information and special symbols below may appear in this manual.

## Assembly Numbers and Grid Coordinates

Each assembly in the instrument is assigned an assembly number (e.g., A20). The assembly number appears on the circuit board outline on the diagram, in the title for the circuit board component location illustration, and in the lookup table for the schematic diagram and corresponding component locator illustration. The Replaceable Electrical Parts list is arranged by assemblies in numerical sequence; the components are listed by component number \*(see following illustration for constructing a component number).

The schematic diagram and circuit board component location illustration have grids. A lookup table with the grid coordinates is provided for ease of locating the component. Only the components illustrated on the facing diagram are listed in the lookup table. When more than one schematic diagram is used to illustrate the circuitry on a circuit board, the circuit board illustration may only appear opposite the first diagram on which it was illustrated; the lookup table will list the diagram number of other diagrams that the circuitry of the circuit board appears on.

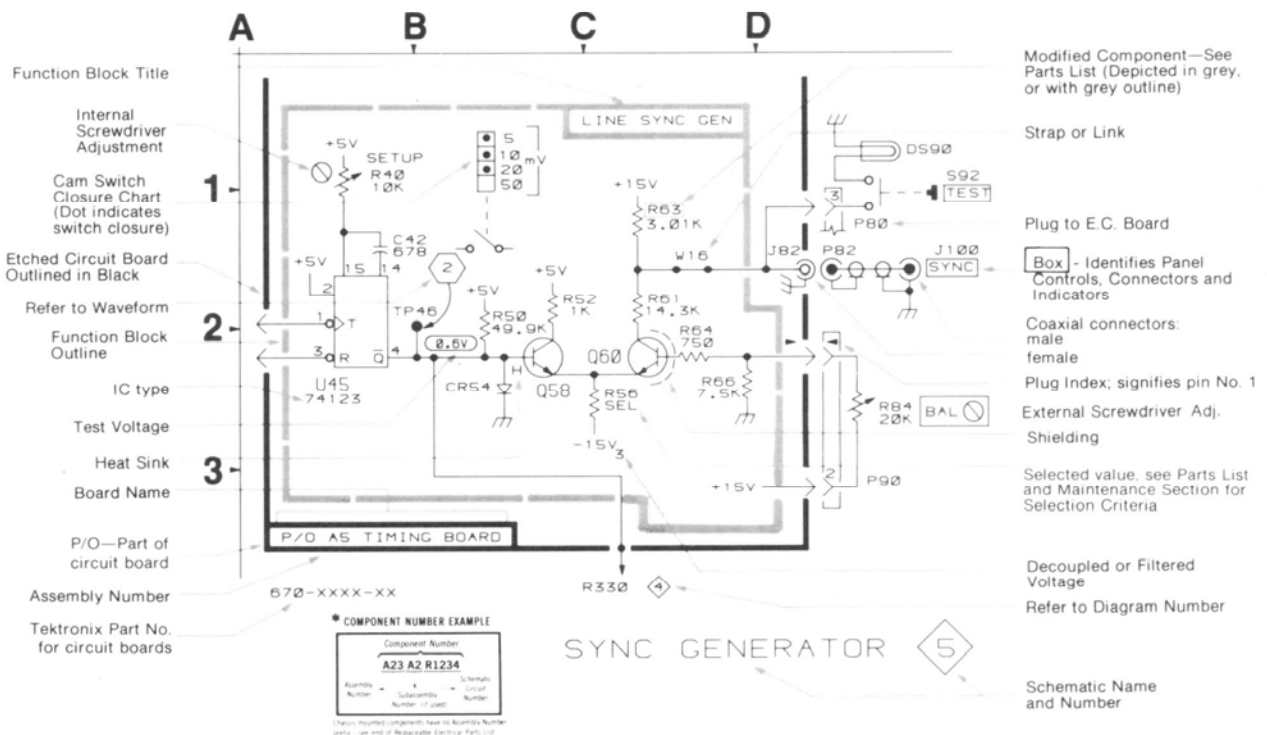

COLOR CODE

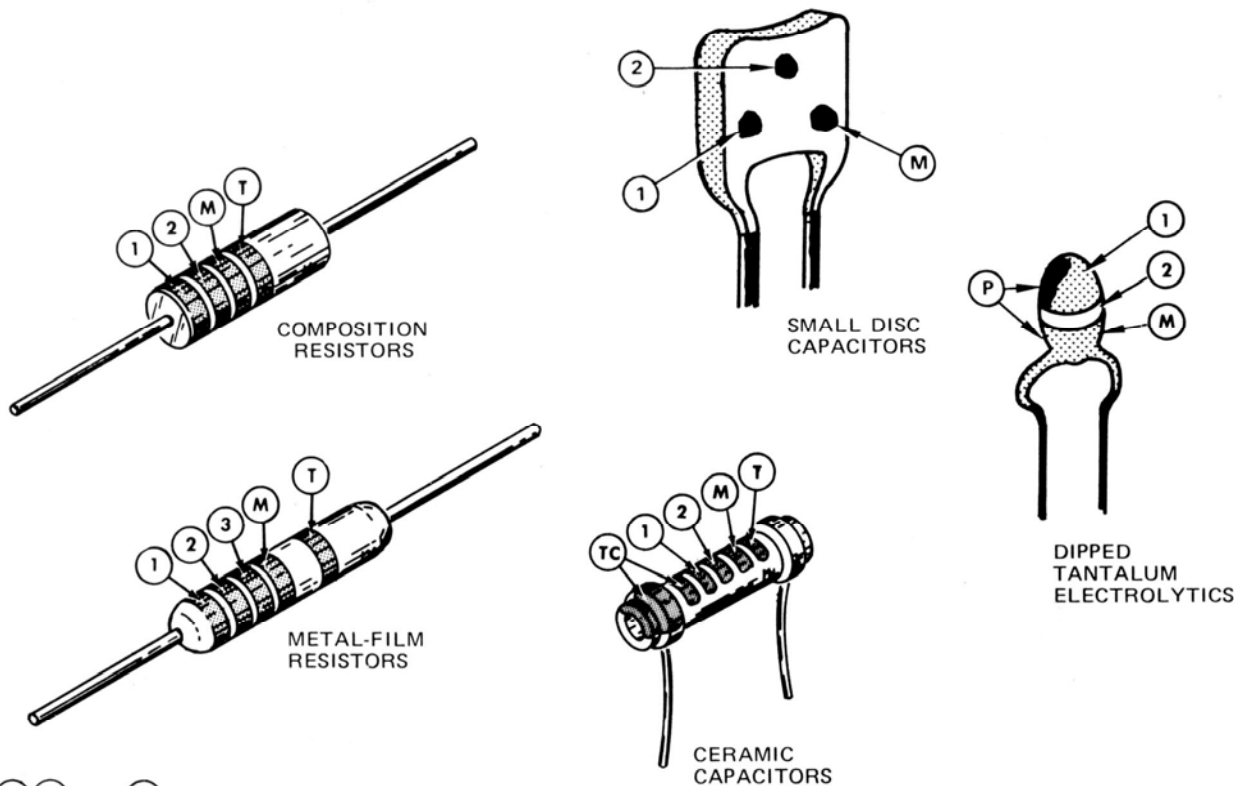

① ② and ③ – 1st, 2nd, and 3rd significant figures

Ⓜ – multiplier      Ⓣ – tolerance

ⓉⓈ – temperature coefficient

Ⓟ – polarity and voltage rating

Ⓣ and/or ⓉⓈ color code may not be present on some capacitors

COLOR	SIGNIFICANT FIGURES	RESISTORS		CAPACITORS			DIPPED TANTALUM VOLTAGE RATING
		MULTIPLIER	TOLERANCE	MULTIPLIER	TOLERANCE		
					over 10 pF	under 10 pF	
BLACK	0	1	----	1	±20%	±2 pF	4 VDC
BROWN	1	10	±1%	10	±1%	±0.1 pF	6 VDC
RED	2	10 <sup>2</sup> or 100	±2%	10 <sup>2</sup> or 100	±2%	----	10 VDC
ORANGE	3	10 <sup>3</sup> or 1 K	±3%	10 <sup>3</sup> or 1000	±3%	----	15 VDC
YELLOW	4	10 <sup>4</sup> or 10 K	±4%	10 <sup>4</sup> or 10,000	+100% –9%	----	20 VDC
GREEN	5	10 <sup>5</sup> or 100 K	±½%	10 <sup>5</sup> or 100,000	±5%	±0.5 pF	25 VDC
BLUE	6	10 <sup>6</sup> or 1 M	±¼%	10 <sup>6</sup> or 1,000,000	----	----	35 VDC
VIOLET	7	----	±1/10%	----	----	----	50 VDC
GRAY	8	----	----	10 <sup>-2</sup> or 0.01	+80% –20%	±0.25 pF	----
WHITE	9	----	----	10 <sup>-1</sup> or 0.1	±10%	±1 pF	3 VDC
GOLD	–	10 <sup>-1</sup> or 0.1	±5%	----	----	----	----
SILVER	–	10 <sup>-2</sup> or 0.01	±10%	----	----	----	----
NONE	–	----	±20%	----	±10%	±1 pF	----

(1861-20A) 2662-48

Figure 9-1. Color codes for resistors and capacitors.

@

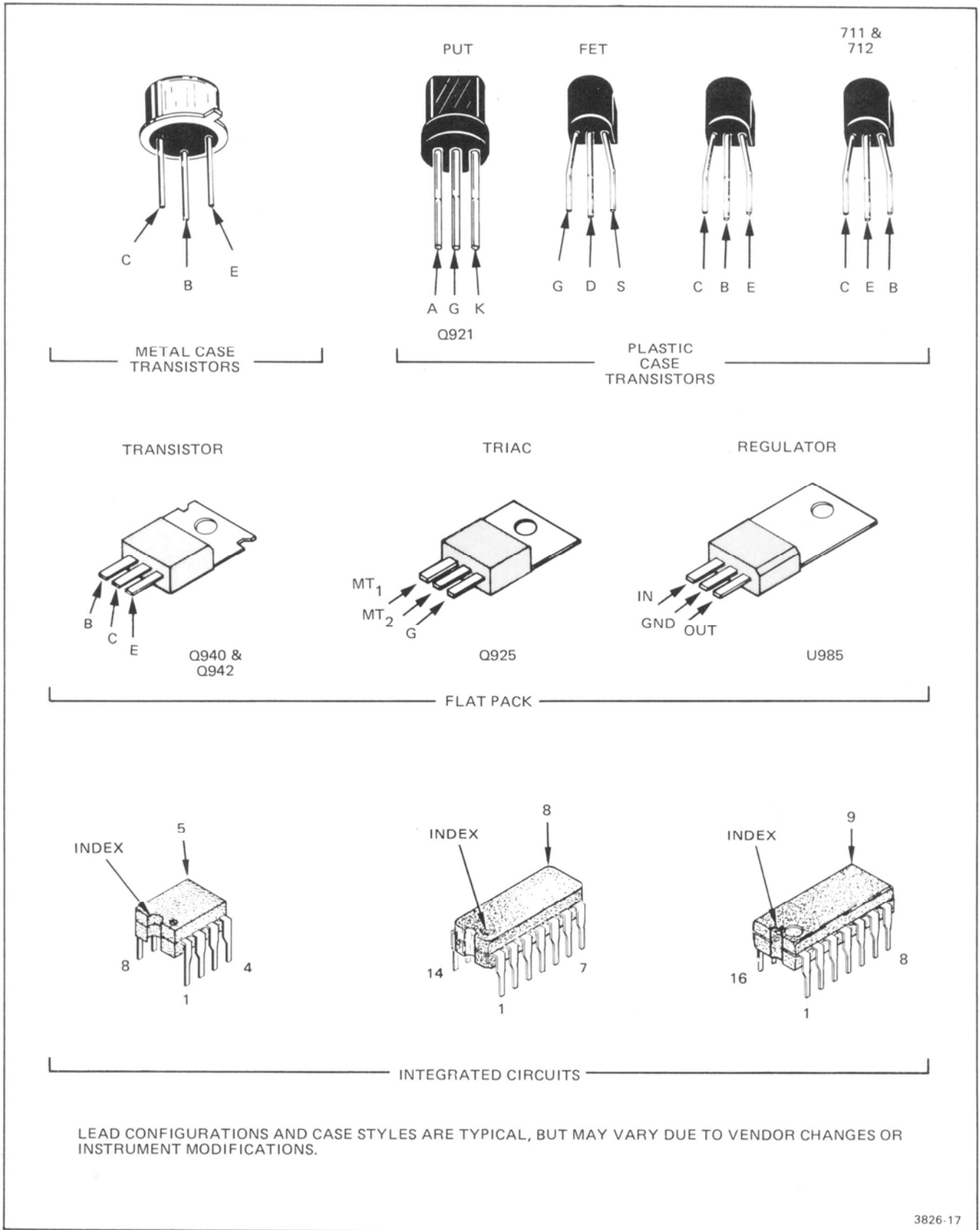

Figure 9-2. Semiconductor lead configurations.

To identify any component mounted on a circuit board and to locate that component in the appropriate schematic diagram

**1. Locate the Circuit Board Illustration**

- a. In the instrument identify the Assembly Number of the circuit board in question. The Assembly Number is usually printed on the upper left corner of the circuit board on the component side.
- b. In the manual locate and pull out tabbed page whose title corresponds with the Assembly Number of the circuit board. Circuit board assembly numbers and board nomenclature are printed on the back side of the tabs (facing the rear of the manual).

**2. Determine the**

- a. Compare th the desired tion.
- b. Scan the tal find the Cir
- c. Determine component

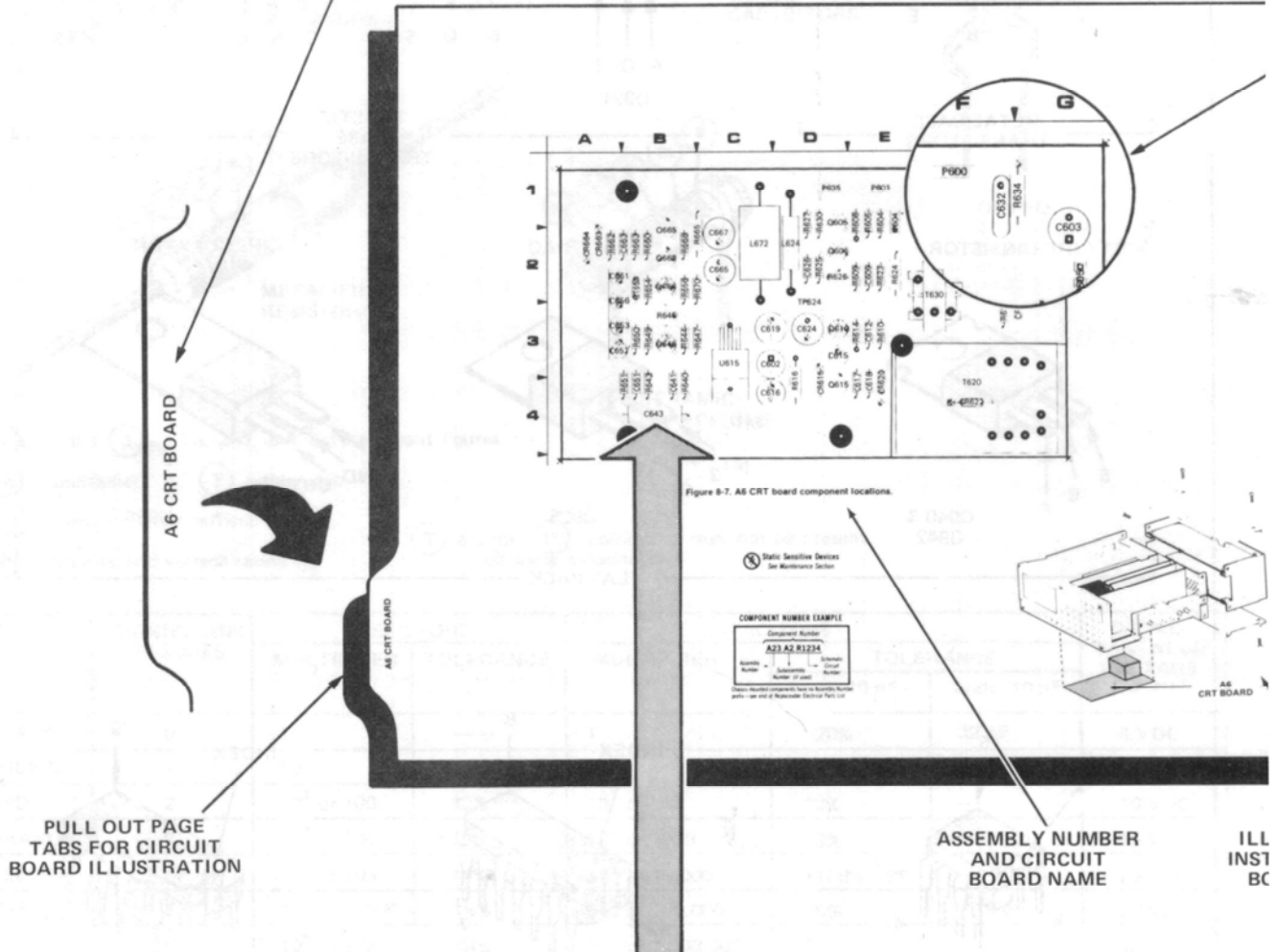

Figure 9-7. A6 CRT board component locations.

PULL OUT PAGE TABS FOR CIRCUIT BOARD ILLUSTRATION

**5. Locate the Component on the Circuit Board**

- a. In the manual, locate and pull out the tabbed page whose title and Assembly Number correspond with the desired circuit board. This information is on the back side of the tabs.
- b. Using the Circuit Number and grid coordinates, locate the component on the Circuit Board Illustration.
- c. In the circuit board location illustration, determine the location of the circuit board in the instrument.
- d. Find the circuit board in the instrument and compare it with its illustration in the manual to locate the desired component on the board.

**4. Determine the Circuit Board Illustration Location**

- a. From the schematic diagram, determine the Assembly Number of the circuit board on which the component is mounted. This information is boxed and underlined in the schematic diagram.
- b. Scan the Component Location Table for the Assembly Number just determined and find the Component Number of the desired component.
- c. Under the BOARD LOCATION column, determine the grid coordinates for the desired component.

Figure 9-3. Locating components on schematic



**Circuit Number**  
 circuit board with its illustration and locate component by area and shape on the illustration adjacent to the Circuit Board Illustration and Unit Number of the desired component.  
 the Schematic Diagram Number in which the component is located.

**3. Loc**  
 a.  
 b.

**A6 CRT BOARD**

COMPONENTS LOCATED ON SCHEMATIC DIAGRAM 10			
C602	C632	Q668	R625
C603	C641		R626
C609	C643	R604	R627
C671	C651	R605	R630
C615		R608	R632
C616	Q606	R609	
C617	Q610	R610	
C618	Q615	R614	
C619	Q645	R616	
C624	Q656	R623	
C626	Q665	R624	

COMPONENTS LOCATED ON SCHEMATIC DIAGRAM 11			
C670	Q670	R677	
C671	Q672	R679	
C673	Q673	R680	
C680			
C681	R671	U617	
P603	R673	U618	
P607	R674	U619	
Q669	R675		

**COMPONENT LOCATION TABLE**

**CRT CIRCUIT DIAGRAM 10**

AN ASSEMBLY					
CIRCUIT NUMBER	SCHEM LOCATION	BOARD LOCATION	CIRCUIT NUMBER	SCHEM LOCATION	BOARD LOCATION
C602	2C	3C	Q656	2F	2B
C603	1C	1G	Q665	1G	1B
C609	4E	2E	Q668	2G	2B
C612	7C	3E			
C615	7C	3D	R604	4C	1E
C616	2C	3C	R605	5D	1E
C617	7D	3D	R608	4E	1D
C618	7E	3E	R609	4E	2D
C619	6E	3C	R610	7B	3E
C624	4F	3D	R614	7C	3D
C626	7G	2D	R616	1C	3D
C632	8G	1F	R623	4D	2E
C643	3D	4B	R625	7F	2D
C651	3E	3B	R626	7F	2D
			R627	7G	1D
			R630	4E	1D
Q606	4E	2D			
Q610	7C	3D	TP624	3B	2D
Q615	7D	3D			
Q645	3E	3B	U615	1D	3C

CHASSIS MOUNTED PARTS					
CIRCUIT NUMBER	SCHEM LOCATION	BOARD LOCATION	CIRCUIT NUMBER	SCHEM LOCATION	BOARD LOCATION
L635	51	CHASSIS	V635	6J	CHASSIS

**CRT CIRCUIT DIAGRAM 10**

**A6 ASSEMBLY**

CIRCUIT NUMBER	SCHEM LOCATION	BOARD LOCATION	CIRCUIT NUMBER	SCHEM LOCATION	BOARD LOCATION
C602	2C	3C	Q656	2F	2B
C603	1C	1G	Q665	1G	1B
C609	4E	2E	Q668	2G	2B
C612	7C	3E			
C615	7C	3D	R604	4C	1E
C616	2C	3C	R605	5D	1E
C617	7D	3D	R608	4E	1D
C618	7E	3E	R609	4E	2D
C619	6E	3C	R610	7B	3E
C624	4F	3D	R614	7C	3D
C626	7G	2D	R616	1C	3D
C632	8G	1F	R623	4D	2E
C643	3D	4B	R625	7F	2D
C651	3E	3B	R626	7F	2D
			R627	7G	1D
			R630	4E	1D
Q606	4E	2D			
Q610	7C	3D	TP624	3B	2D
Q615	7D	3D			
Q645	3E	3B	U615	1D	3C

CHASSIS MOUNTED PARTS					
CIRCUIT NUMBER	SCHEM LOCATION	BOARD LOCATION	CIRCUIT NUMBER	SCHEM LOCATION	BOARD LOCATION
L635	51	CHASSIS	V635	6J	CHASSIS

**A6 CRT BOARD**

COMPONENTS LOCATED ON SCHEMATIC DIAGRAM 10			
C602	C632	Q668	R625
C603	C641		R626
C609	C643	R604	R627
C671	C651	R605	R630
C615		R608	R632
C616	Q606	R609	
C617	Q610	R610	
C618	Q615	R614	
C619	Q645	R616	
C624	Q656	R623	
C626	Q665	R624	

COMPONENTS LOCATED ON SCHEMATIC DIAGRAM 11			
C670	Q670	R677	
C671	Q672	R679	
C673	Q673	R680	
C680			
C681	R671	U617	
P603	R673	U618	
P607	R674	U619	
Q669	R675		

**ILLUSTRATION FOR COMPONENT CIRCUIT BOARD LOCATION**

**Find Component**  
 Determine the Assembly in which the component is located in a corner of the board outline.

**Procedure**  
 For the Assembly Circuit Number of the component, read the grid

**References**  
 Diagrams and circuit board illustrations.



### 3. Locate the Component on the Schematic Diagram

- Locate and pull out tabbed page whose number and title correspond with the Schematic Diagram Number just determined in the table. Schematic diagram nomenclature and numbers are printed on the front side of the tabs (facing the front of the manual).
- Scan the Component Location Table adjacent to the schematic diagram and find the Circuit Number of the desired component.
- Under the SCHEM LOCATION column, read the grid coordinates for the desired component.
- Using the Circuit Number and grid coordinates, locate the component on the schematic diagram.

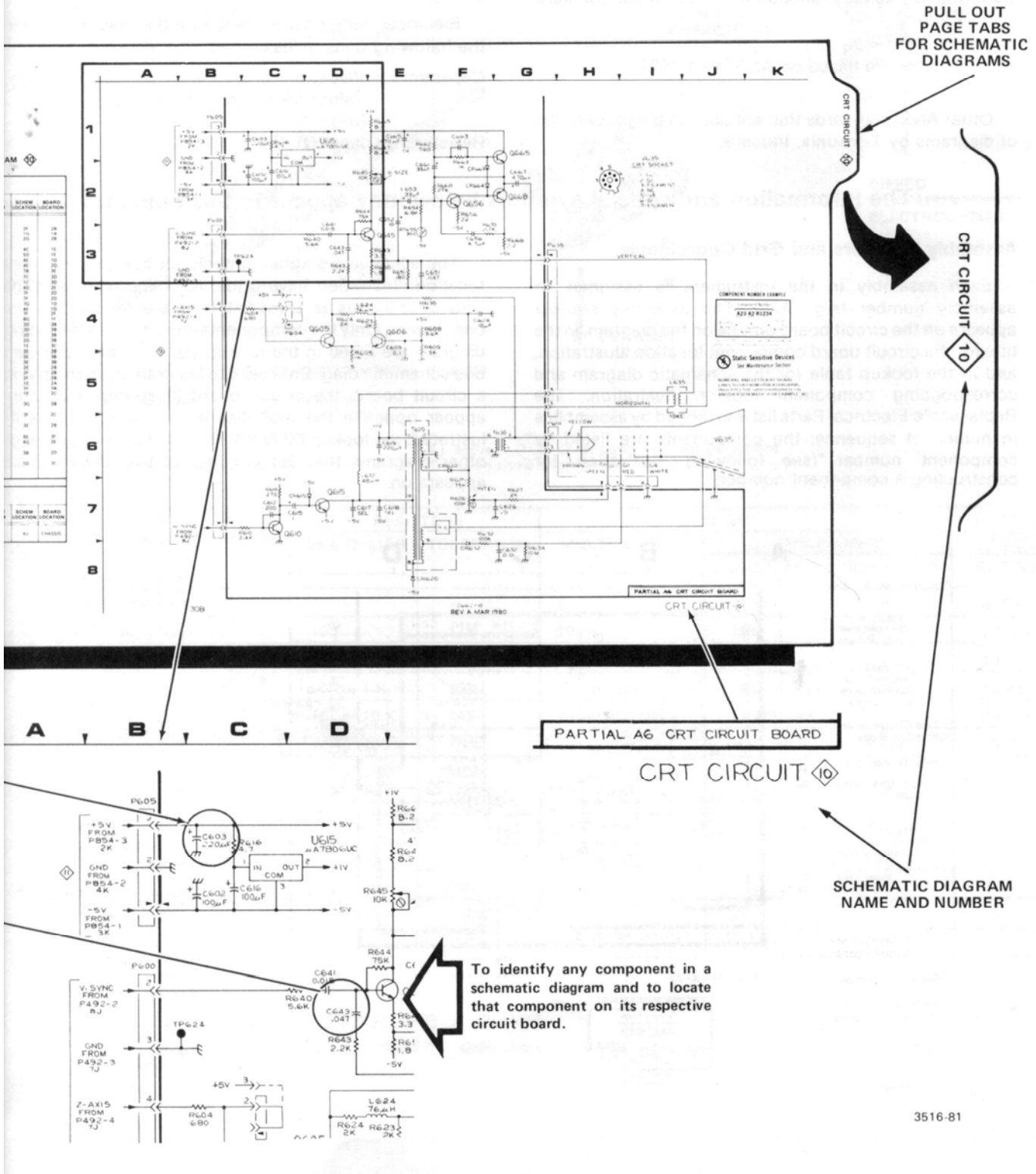

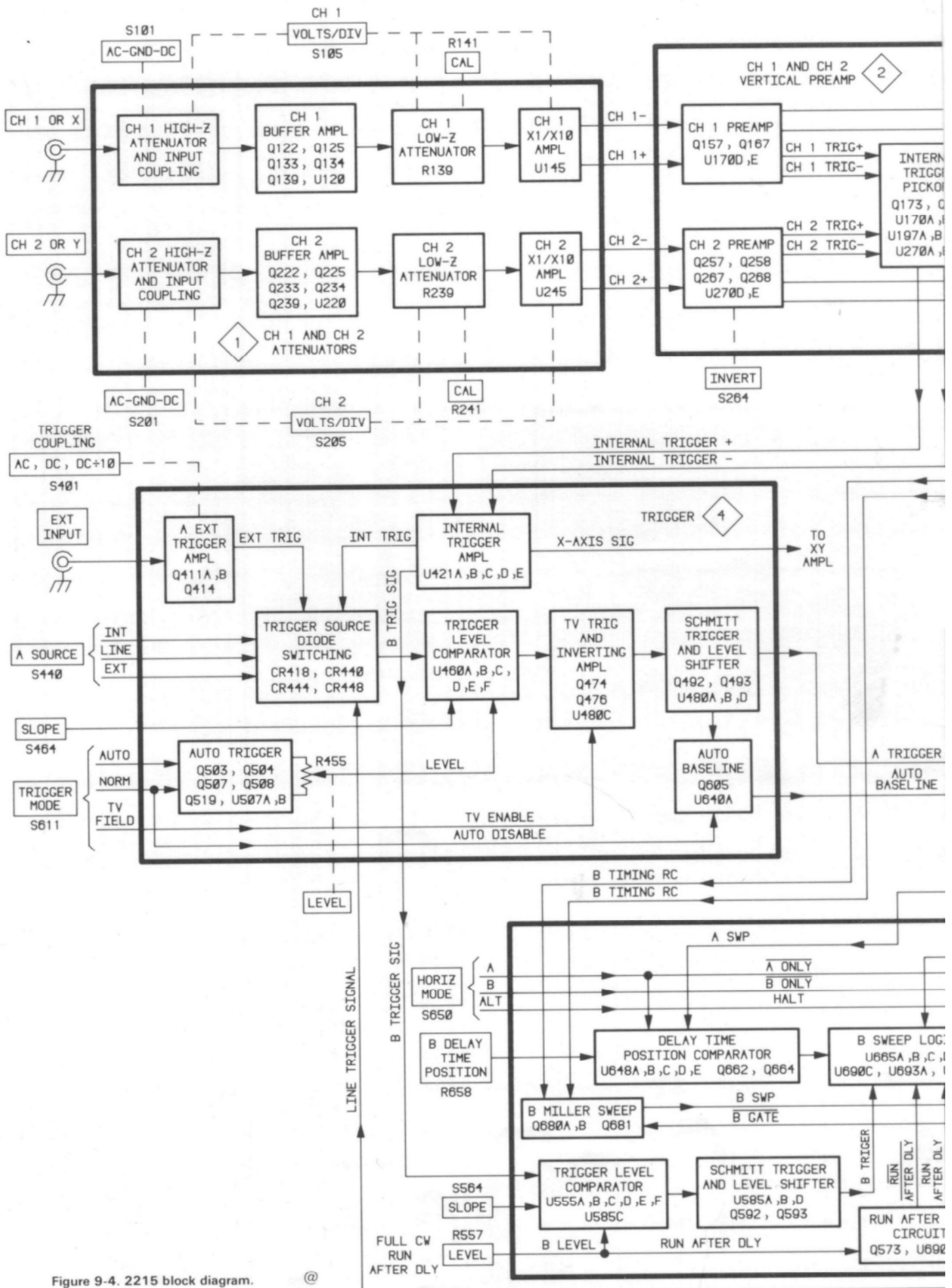
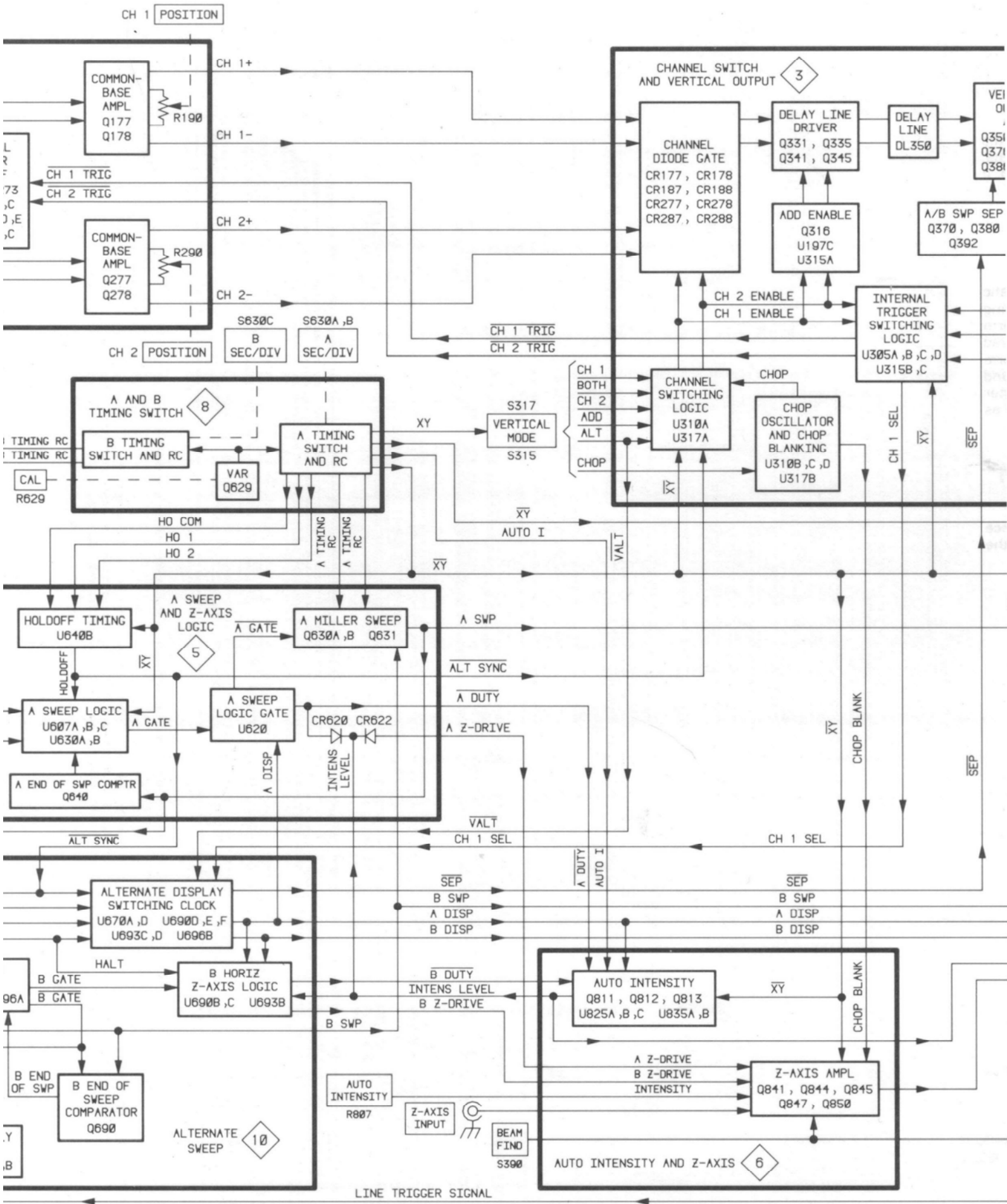
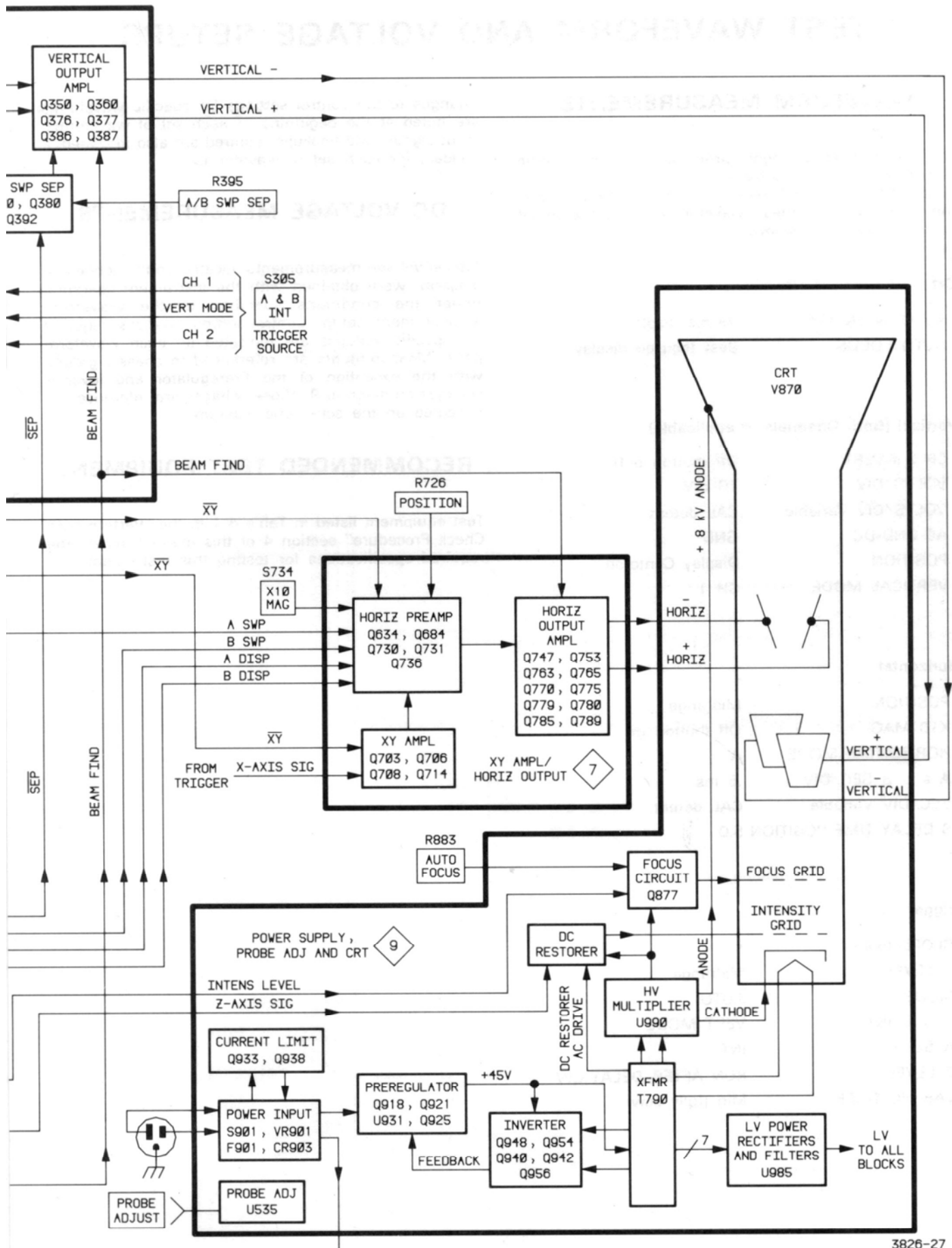

Figure 9-4. 2215 block diagram.





# TEST WAVEFORM AND VOLTAGE SETUPS

## WAVEFORM MEASUREMENTS

On the left-hand pages preceding the schematic diagrams are test waveform illustrations that are intended to aid in troubleshooting the instrument. To test the instrument for these waveforms, make the initial control settings as follows:

### Crt

AUTO INTENSITY	Visible display
AUTO FOCUS	Best focused display

### Vertical (Both Channels, if applicable)

CH 2 INVERT	Off (button out)
VOLTS/DIV	10 mV
VOLTS/DIV Variable	CAL detent
AC-GND-DC	GND
POSITION	Display Centered
VERTICAL MODE	CH 1

### Horizontal

POSITION	Midrange
X10 MAG	Off (button in)
HORIZONTAL MODE	A
A and B SEC/DIV	.5 ms
SEC/DIV Variable	CAL detent
B DELAY TIME POSITION	5.0

### Trigger

SLOPE (both	+
A LEVEL	Midrange
MODE	AUTO
A & B INT	VERT MODE
A SOURCE	INT
B LEVEL	RUN AFTER DELAY-CW
VAR HOLDOFF	Min (fully ccw)

Changes to the control settings for specific waveforms are noted at the beginning of each set of waveforms. Input signals and hookups required are also indicated, if needed, for each set of waveforms.

## DC VOLTAGE MEASUREMENTS

Typical voltage measurements, located on the schematic diagram, were obtained with the instrument operating under the conditions specified in the Waveform Measurement setup. Control-setting changes required for specific voltages are indicated on each waveform page. Measurements are referenced to chassis ground with the exception of the Preregulator and Inverter voltages on diagram 9. Those voltages are referenced as indicated on the schematic diagram.

## RECOMMENDED TEST EQUIPMENT

Test equipment listed in Table 4-1 in the "Performance Check Procedure" section 4 of this manual, meets the required specifications for testing this instrument.

### POWER SUPPLY ISOLATION PROCEDURE

Each regulated supply has numerous feed points to external loads throughout the instrument. The power distribution diagram is used in conjunction with the schematic diagrams to determine those loads that can be isolated by removing service jumpers and those that cannot.

The power distribution diagram is divided into circuit boards. Each power supply feed to a circuit board is indicated by the schematic diagram number on which the voltage appears. The schematic diagram grid location of a service jumper or component is given adjacent to the component number on the power distribution diagram.

If a power supply comes up after lifting one of the main jumpers from the power supply to isolate that supply, it is very probable that a short exist in the circuitry on that supply line. By lifting jumpers farther down the line, the circuit in which a short exist may be located.

Typical resistance values to ground from the regulated supplies output as measured at the supply test points are:

-8.6 V	114 $\Omega$ at TP500
+8.6 V	95 $\Omega$ at W975
+5 V	330 $\Omega$ at W985
+30 V	905 $\Omega$ at W965
+100 V	12.5 k $\Omega$ at W966

Resistance values significantly lower may indicate shorted components in the load. Values will vary between instruments.

Always set the POWER switch to OFF before soldering or unsoldering service jumpers or other components and before attempting to measure component resistance values.

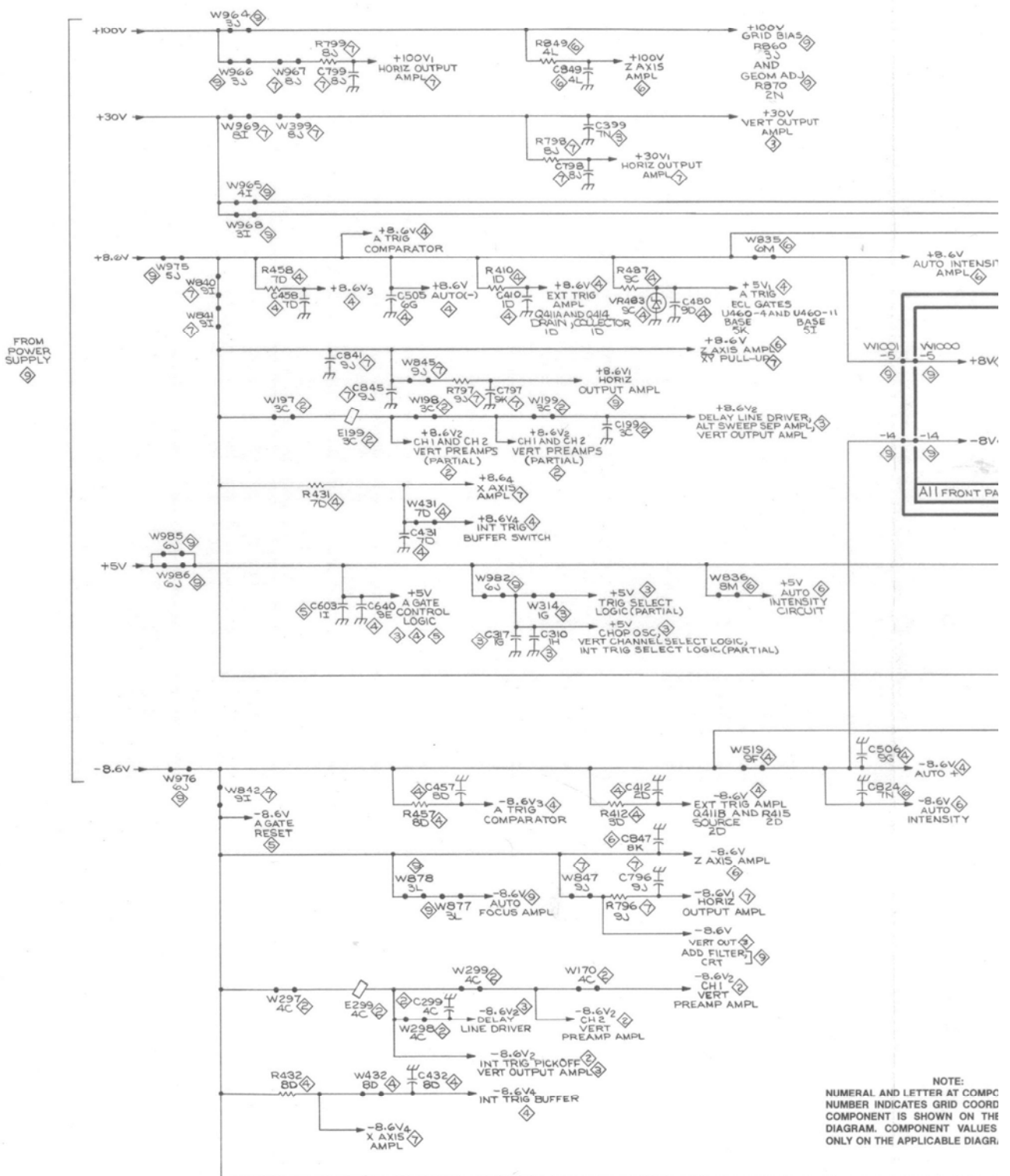



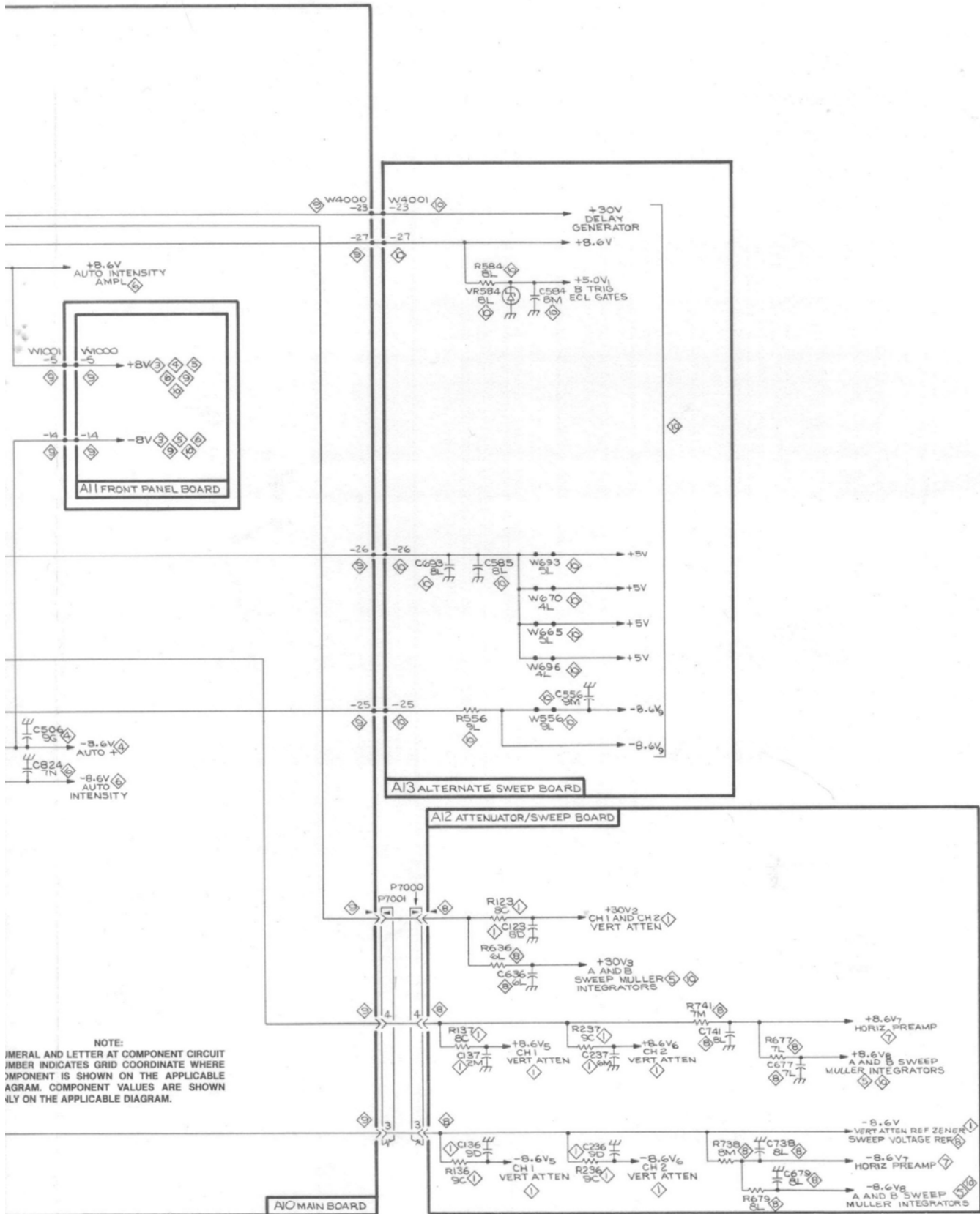

NOTE:  
 NUMERICAL AND LETTER AT COMPONENT CIRCUIT  
 NUMBER INDICATES GRID COORDINATE WHERE  
 COMPONENT IS SHOWN ON THE APPLICABLE  
 DIAGRAM. COMPONENT VALUES ARE SHOWN  
 FULLY ON THE APPLICABLE DIAGRAM.

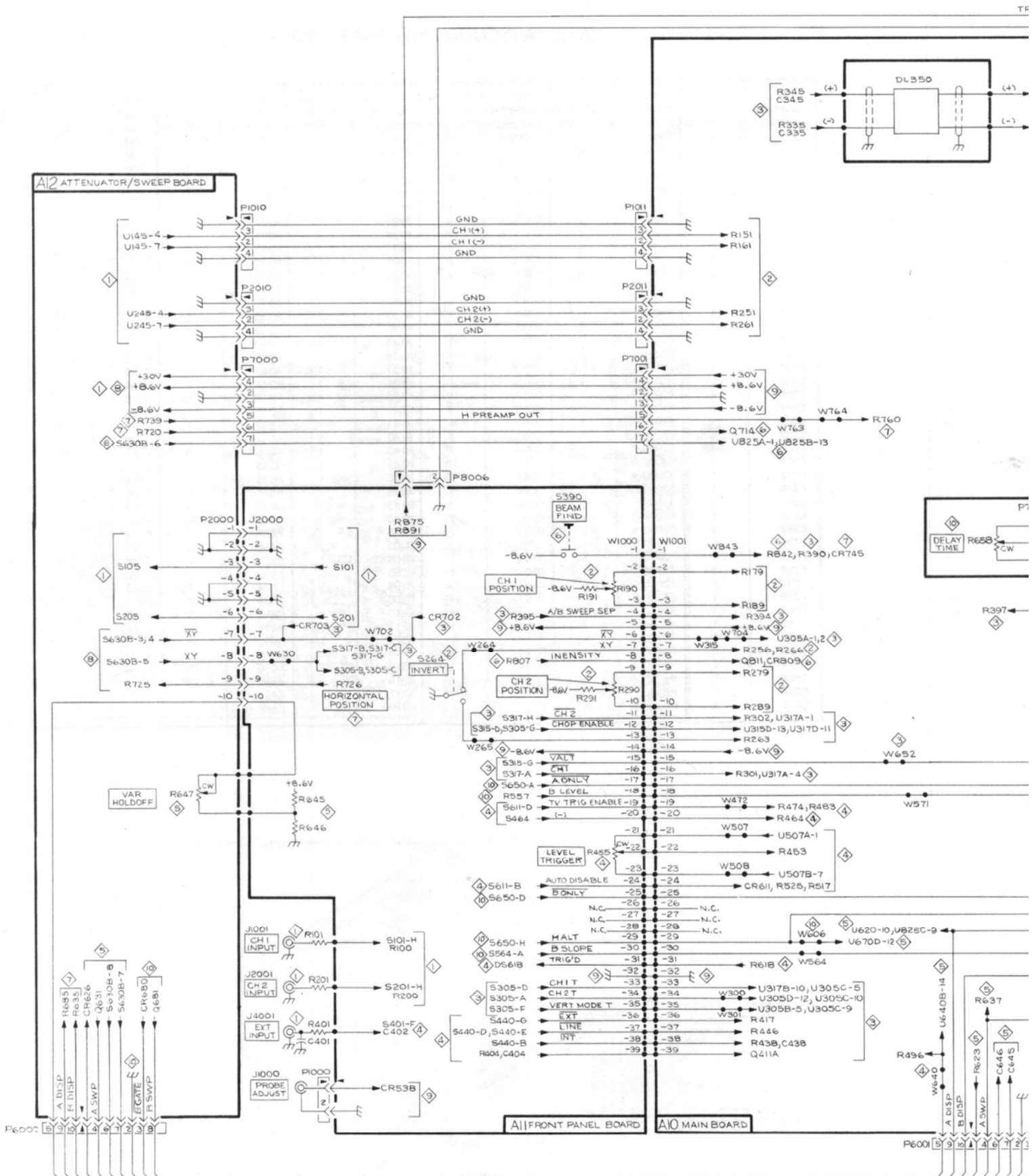

TRACE ROTATION  
GND

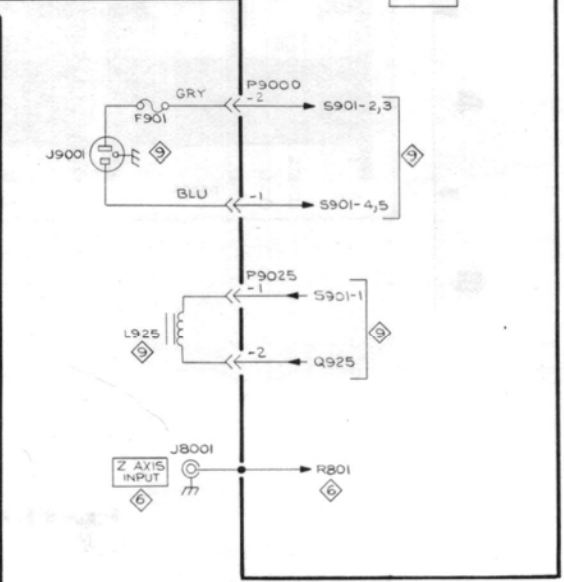
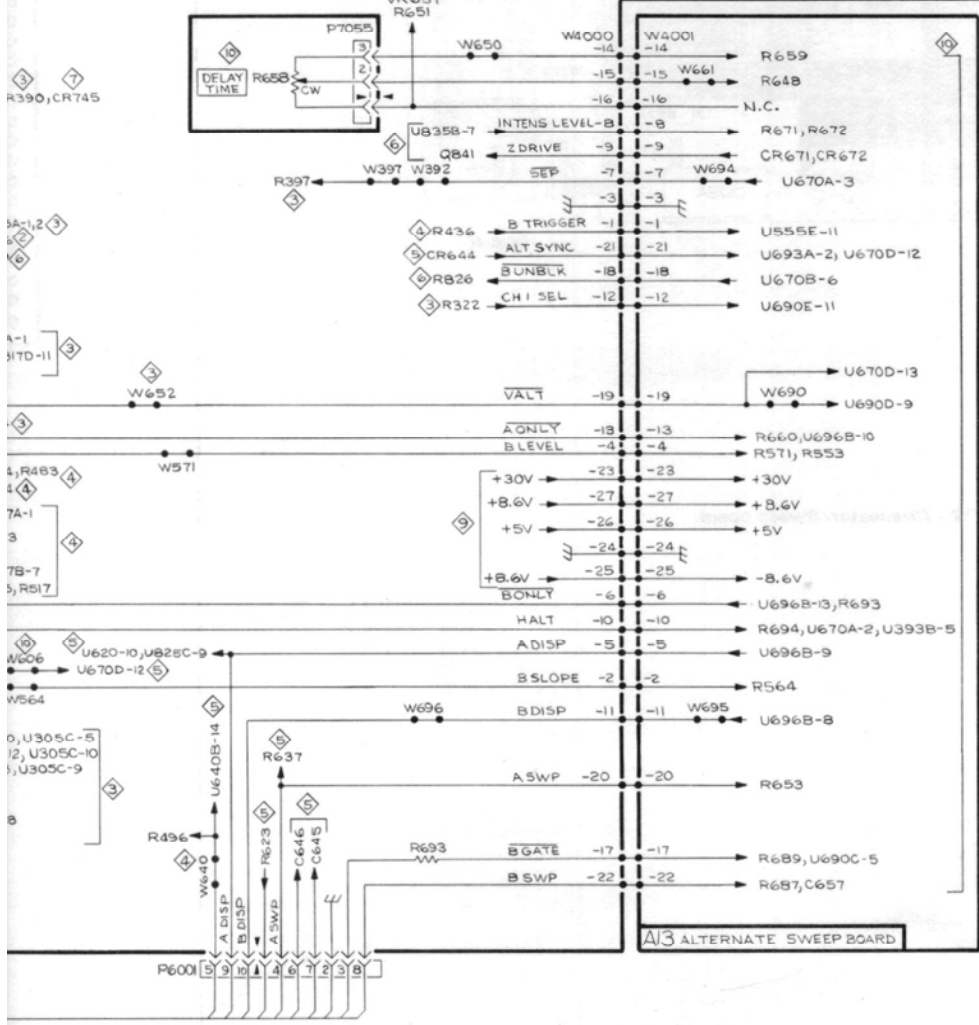
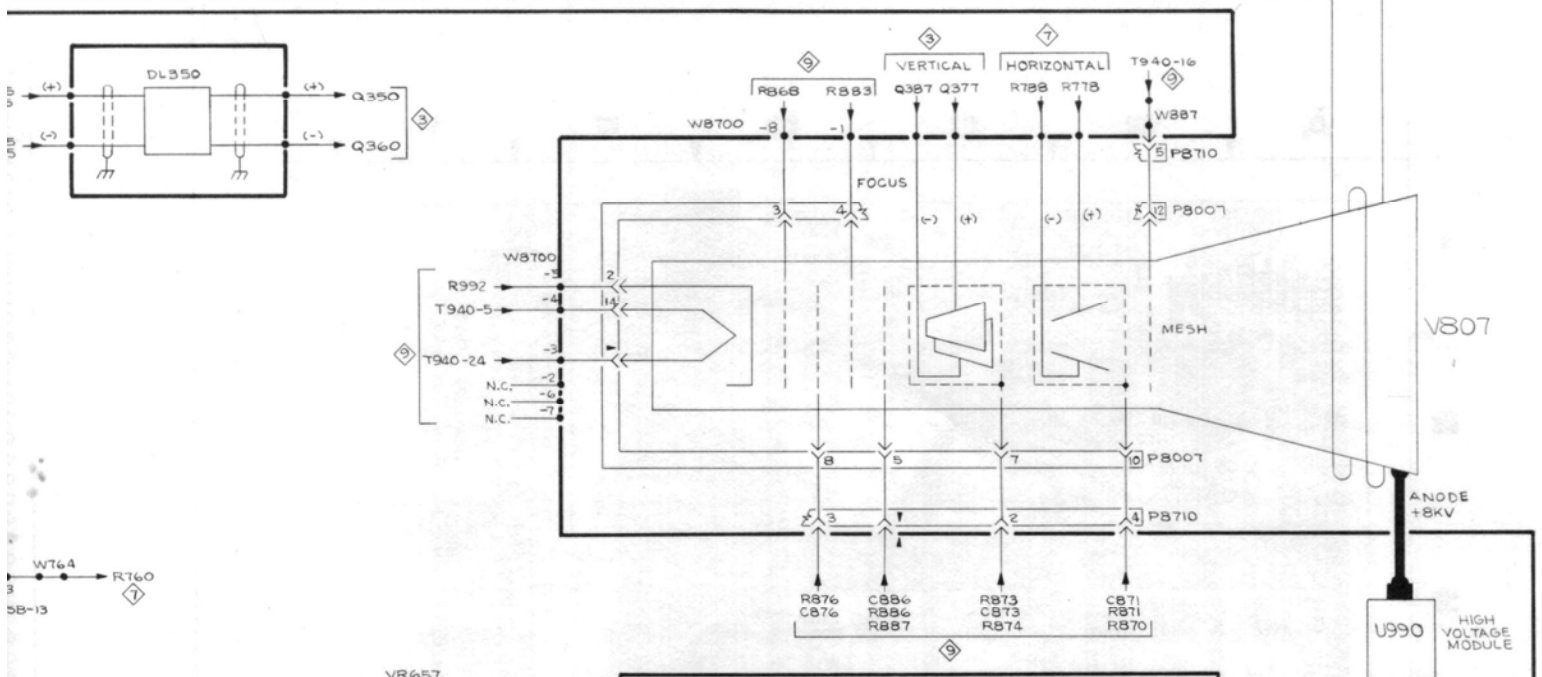

3826-30  
©

CIRCUIT BOARD INTERCONNECTIONS

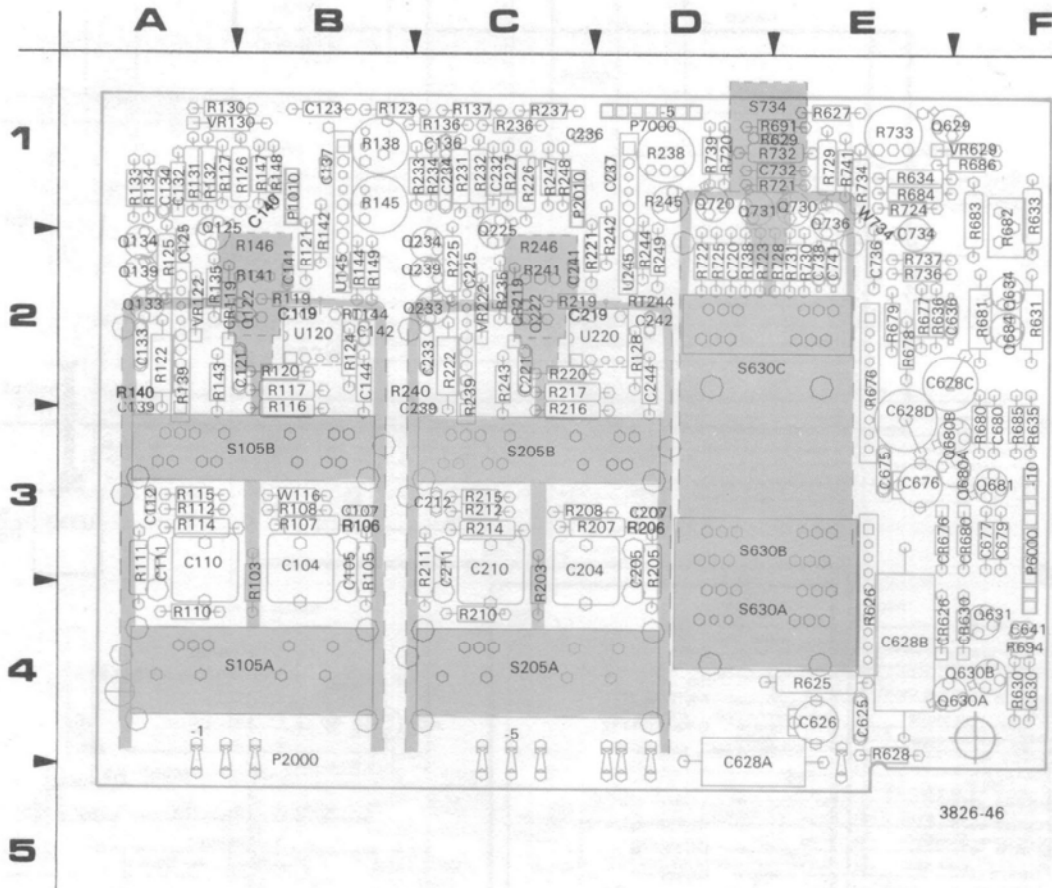
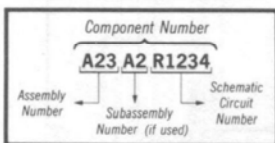

Figure 9-5. A12—Attenuator/Sweep board.

 Static Sensitive Devices  
See Maintenance Section

COMPONENT NUMBER EXAMPLE



Chassis-mounted components have no Assembly Number prefix—see end of Replaceable Electrical Parts List.

## A12—ATTENUATOR/SWEEP BOARD

CIRCUIT NUMBER	SCHEM NUMBER	CIRCUIT NUMBER	SCHEM NUMBER	CIRCUIT NUMBER	SCHEM NUMBER	CIRCUIT NUMBER	SCHEM NUMBER	CIRCUIT NUMBER	SCHEM NUMBER	CIRCUIT NUMBER	SCHEM NUMBER
C104	1	C641	5	P6000-8	10	R119	1	R220	1	R683	7
C105	1	C675	8	P6000-9	7	R120	1	R221	1	R684	7
C107	1	C676	8	P6000-10	7	R121	1	R222	1	R685	7
C110	1	C677	8	P7000-1	8	R122	1	R225	1	R686	8
C111	1	C679	8	P7000-2	8	R123	1	R226	1	R691	8
C112	1	C680	10	P7000-3	8	R124	1	R227	1	R694	5
C119	1	C720	7	P7000-4	8	R125	1	R231	1	R720	7
C121	1	C732	7	P7000-5	7	R126	1	R232	1	R721	7
C123	1	C734	7	P7000-6	7	R127	1	R233	1	R722	7
C125	1	C736	7	P7000-7	8	R128	1	R234	1	R723	7
C132	1	C738	8	Q122	1	R130	1	R235	1	R724	7
C133	1	C741	8	Q125	1	R131	1	R236	1	R725	7
C134	1	CR119	1	Q133	1	R132	1	R237	1	R728	7
C136	1	CR219	1	Q134	1	R133	1	R238	1	R729	7
C137	1	CR626	5	Q139	1	R134	1	R239	1	R730	7
C139	1	CR630	5	Q222	1	R135	1	R240	1	R731	7
C140	1	CR676	10	Q225	1	R136	1	R241	1	R732	7
C141	1	CR680	10	Q233	1	R137	1	R242	1	R733	7
C142	1	P1010-1	1	Q234	1	R138	1	R243	1	R734	7
C144	1	P1010-2	1	Q239	1	R139	1	R244	1	R736	7
C204	1	P1010-3	1	Q629	8	R140	1	R245	1	R737	7
C205	1	P1010-4	1	Q630	5	R141	1	R246	1	R738	8
C207	1	P2000-1	1	Q631	5	R142	1	R247	1	R739	7
C210	1	P2000-2	1	Q634	7	R143	1	R248	1	R741	8
C211	1	P2000-3	1	Q680	10	R144	1	R249	1	RT144	1
C212	1	P2000-4	1	Q681	10	R145	1	R625	8	RT244	1
C219	1	P2000-5	1	Q684	7	R146	1	R626	8	S105	1
C221	1	P2000-6	1	Q720	7	R147	1	R627	8	S205	1
C225	1	P2000-7	8	Q730	7	R148	1	R628	8	S630	8
C232	1	P2000-8	8	Q731	7	R149	1	R629	8	S734	7
C233	1	P2000-9	7	Q736	7	R203	1	R630	5	U120	1
C234	1	P2000-10	5	R103	1	R205	1	R631	5	U145	1
C236	1	P2010-1	1	R105	1	R206	1	R633	7	U220	1
C237	1	P2010-2	1	R106	1	R207	1	R634	7	U245	1
C239	1	P2010-3	1	R107	1	R208	1	R635	7	VR122	1
C241	1	P2010-4	1	R108	1	R210	1	R636	8	VR130	1
C242	1	P6000-1	5	R110	1	R211	1	R676	8	VR222	1
C244	1	P6000-2	10	R111	1	R212	1	R677	8	VR629	8
C625	8	P6000-3	10	R112	1	R214	1	R678	8	W116	1
C626	8	P6000-4	5	R114	1	R215	1	R679	8	W734	7
C628	8	P6000-5	5	R115	1	R216	1	R680	10		
C630	5	P6000-6	5	R116	1	R217	1	R681	10		
C636	8	P6000-7	5	R117	1	R219	1	R682	7		

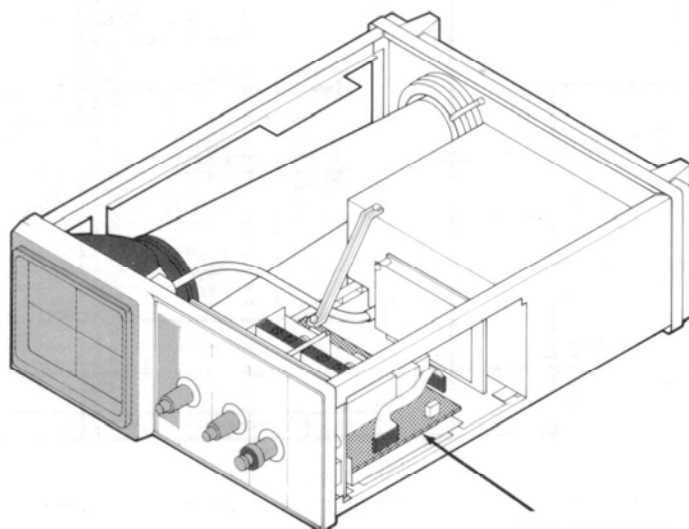

A12—ATTENUATOR/SWEEP

REV OCT 1981

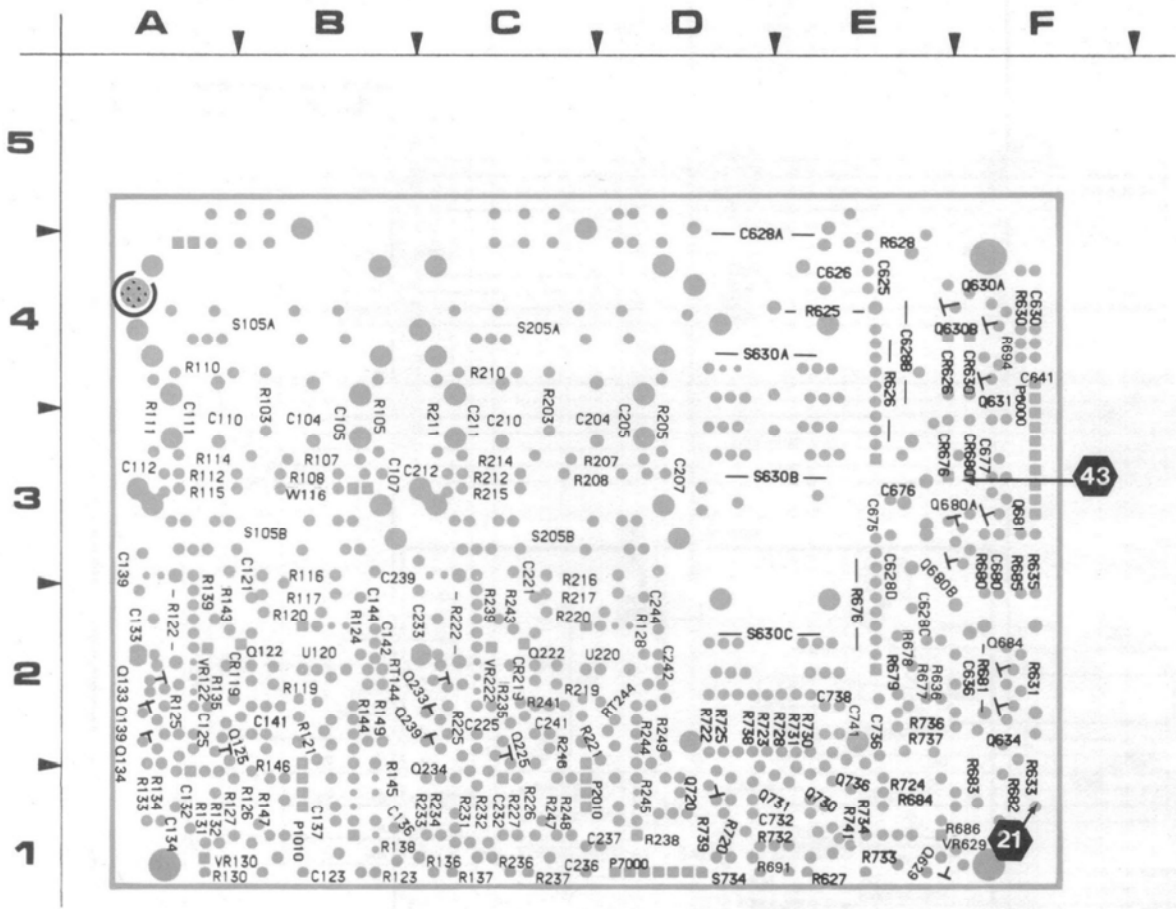

3826-47

Figure 9-6. Circuit view of A12—Attenuator/Sweep board.

 Static Sensitive Devices  
See Maintenance Section

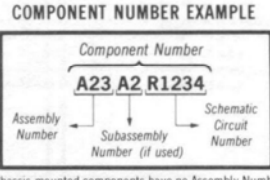

Chassis-mounted components have no Assembly Number prefix—see end of Replaceable Electrical Parts List.

## CH 1 & CH 2 ATTENUATORS



<b>ASSEMBLY A11</b>											
CIRCUIT NUMBER	SCHEM LOCATION	BOARD LOCATION	CIRCUIT NUMBER	SCHEM LOCATION	BOARD LOCATION	CIRCUIT NUMBER	SCHEM LOCATION	BOARD LOCATION	CIRCUIT NUMBER	SCHEM LOCATION	BOARD LOCATION
C101	3C	3B	J2000-2	2C	3B	R100	2B	3A	S101	2B	3B
C102	2C	3B	J2000-3	2C	3B	R102	2C	3B	S201	7B	3C
C202	6B	3C	J2000-4	7C	3C	R200	6B	3C			
			J2000-5	7C	3C	R202	6C	3C			
J2000-1	3C	3A	J2000-6	6C	3C						

*Partial A11 also shown on diagrams 2, 3, 4, 5, 6, 7, 8, 9 and 10.*

<b>ASSEMBLY A12</b>											
CIRCUIT NUMBER	SCHEM LOCATION	BOARD LOCATION	CIRCUIT NUMBER	SCHEM LOCATION	BOARD LOCATION	CIRCUIT NUMBER	SCHEM LOCATION	BOARD LOCATION	CIRCUIT NUMBER	SCHEM LOCATION	BOARD LOCATION
C104	2E	3B	P1010-1	2N	1B	R123	8C	1B	R225	8H	2C
C105	2E	3B	P1010-2	2N	1B	R124	6I	2B	R226	9H	1C
C107	3E	3B	P1010-3	4N	1B	R125	3H	2A	R227	8H	1C
C110	3E	3A	P1010-4	4N	1B	R126	4H	1B	R231	6H	1C
C111	3E	3A	P2000-1	3C	4A	R127	4H	1A	R232	6G	1C
C112	3E	3A	P2000-2	2C	4A	R128	6J	2D	R233	7I	1C
C119	2G	2B	P2000-3	2C	4B	R130	5H	1A	R234	8H	1C
C121	2G	2B	P2000-4	7C	4C	R131	5H	1A	R235	8I	2C
C123	8D	1B	P2000-5	7C	4C	R132	5G	1A	R236	9C	1C
C125	3H	2A	P2000-6	6C	4C	R133	2I	1A	R237	9C	1C
C132	5G	1A	P2010-1	6N	1C	R134	4H	1A	R238	9K	1D
C133	2I	2A	P2010-2	7N	1C	R135	3I	2A	R239	7J	2C
C134	4I	1A	P2010-3	9N	1C	R136	9C	1C	R240	7K	2C
C136	9D	1C	P2010-4	9N	1C	R137	8C	1C	R241	7K	2C
C137	8D	1B				R138	5K	1B	R242	7K	2D
C139	3J	3A	Q122	2H	2B	R139	2J	2A	R243	9K	2C
C140	2N	1B	Q125	4H	1A	R140	3K	2A	R244	8N	2D
C141	2K	2B	Q133	2H	2A	R141	3K	2B	R245	8N	1D
C142	2N	2B	Q134	4H	2A	R142	2K	2B	R246	9K	2C
C144	4L	2B	Q139	3I	2A	R143	4K	2A	R247	9L	1C
C204	7E	3C	Q222	7H	2C	R144	3N	2B	R248	9L	1C
C205	7E	3D	Q225	8H	2C	R145	3N	1B	R249	8N	2D
C207	7E	3D	Q233	7H	2C	R146	4K	2B			
C210	8E	3C	Q234	8H	2C	R147	4L	1B	RT144	3N	2B
C211	7E	3C	Q239	8I	2C	R148	4L	1B	RT244	8N	2D
C212	8E	3C				R149	3N	2B			
C219	7G	2C	R103	2E	3B	R203	6E	4C	S105A	1E	3B
C221	6G	2C	R105	2E	3B	R205	7E	3D	S105B	1K	3B
C225	8H	2C	R106	2E	3B	R206	7E	3D	S205A	5E	3C
C232	6G	1C	R107	3F	3B	R207	7F	3C	S205B	5K	3C
C233	7I	2C	R108	2F	3B	R208	7F	3C			
C234	8I	1C	R110	3E	4A	R210	7E	4C	U120	2G	2B
C236	9D	1C	R111	3E	3A	R211	8E	2C	U145	2L	2B
C237	8D	1D	R112	3E	3A	R212	8E	3C	U220	7G	2D
C239	8J	3C	R114	3F	3A	R214	8F	3C	U245	7L	2D
C241	7K	2C	R115	3F	3A	R215	7F	3C			
C242	7N	2D	R116	2G	3B	R216	7G	3C	VR122	2I	2A
C244	8L	2D	R117	2G	2B	R217	7G	2C	VR130	6H	1A
			R119	2G	2B	R219	7G	2C	VR222	6I	2C
CR119	3H	2A	R120	3G	2B	R220	8G	2C			
CR219	8G	2C	R121	3G	2B	R221	6G	2C	W116	2G	3B
			R122	2H	2A	R222	6H	2C			

*Partial A12 also shown on diagrams 5, 7, 8 and 10.*

<b>CHASSIS MOUNTED PARTS</b>											
CIRCUIT NUMBER	SCHEM LOCATION	BOARD LOCATION	CIRCUIT NUMBER	SCHEM LOCATION	BOARD LOCATION	CIRCUIT NUMBER	SCHEM LOCATION	BOARD LOCATION	CIRCUIT NUMBER	SCHEM LOCATION	BOARD LOCATION
J1001	2A	CHASSIS	R101	2A	CHASSIS						
J2001	7A	CHASSIS	R201	7A	CHASSIS						

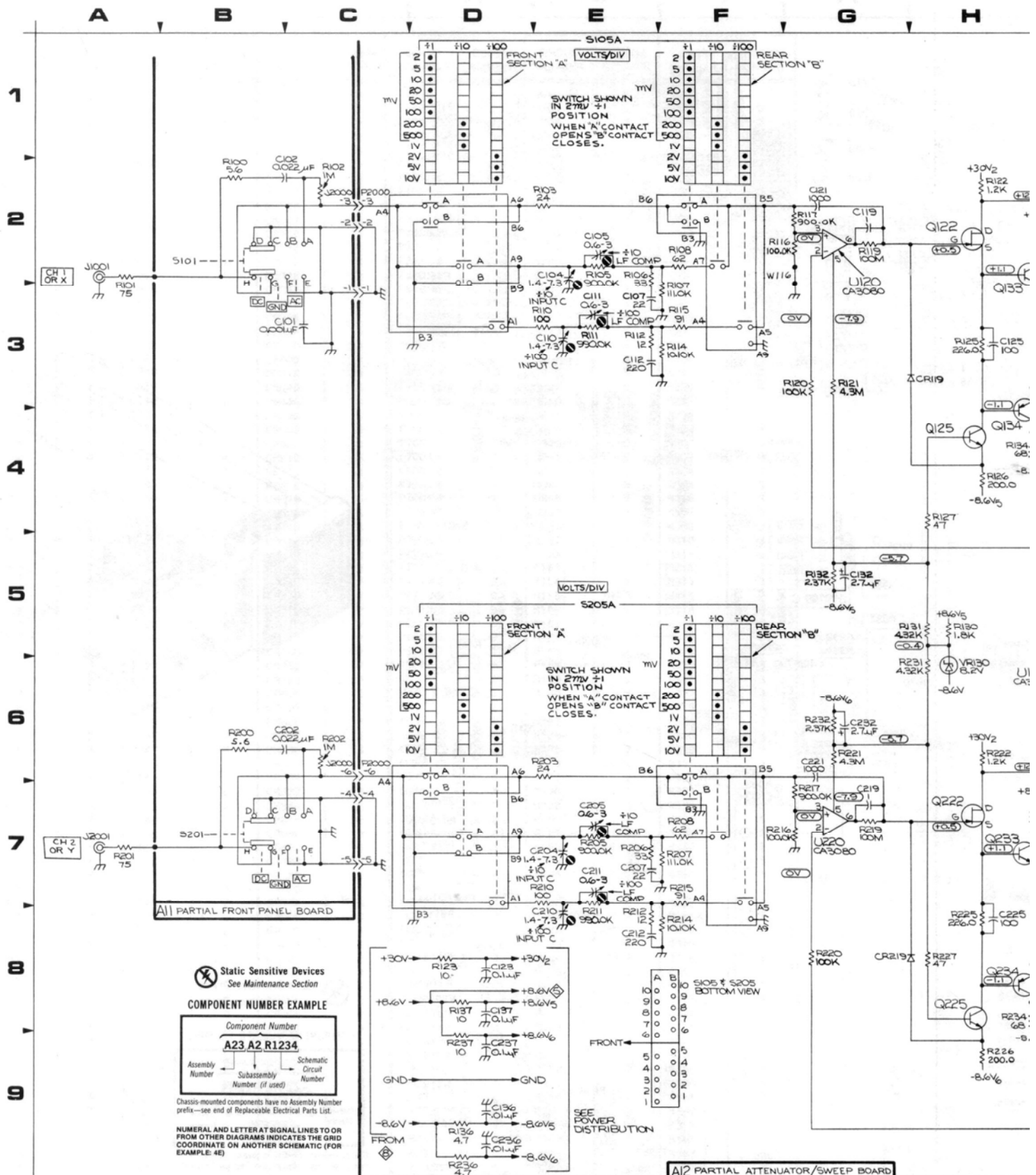



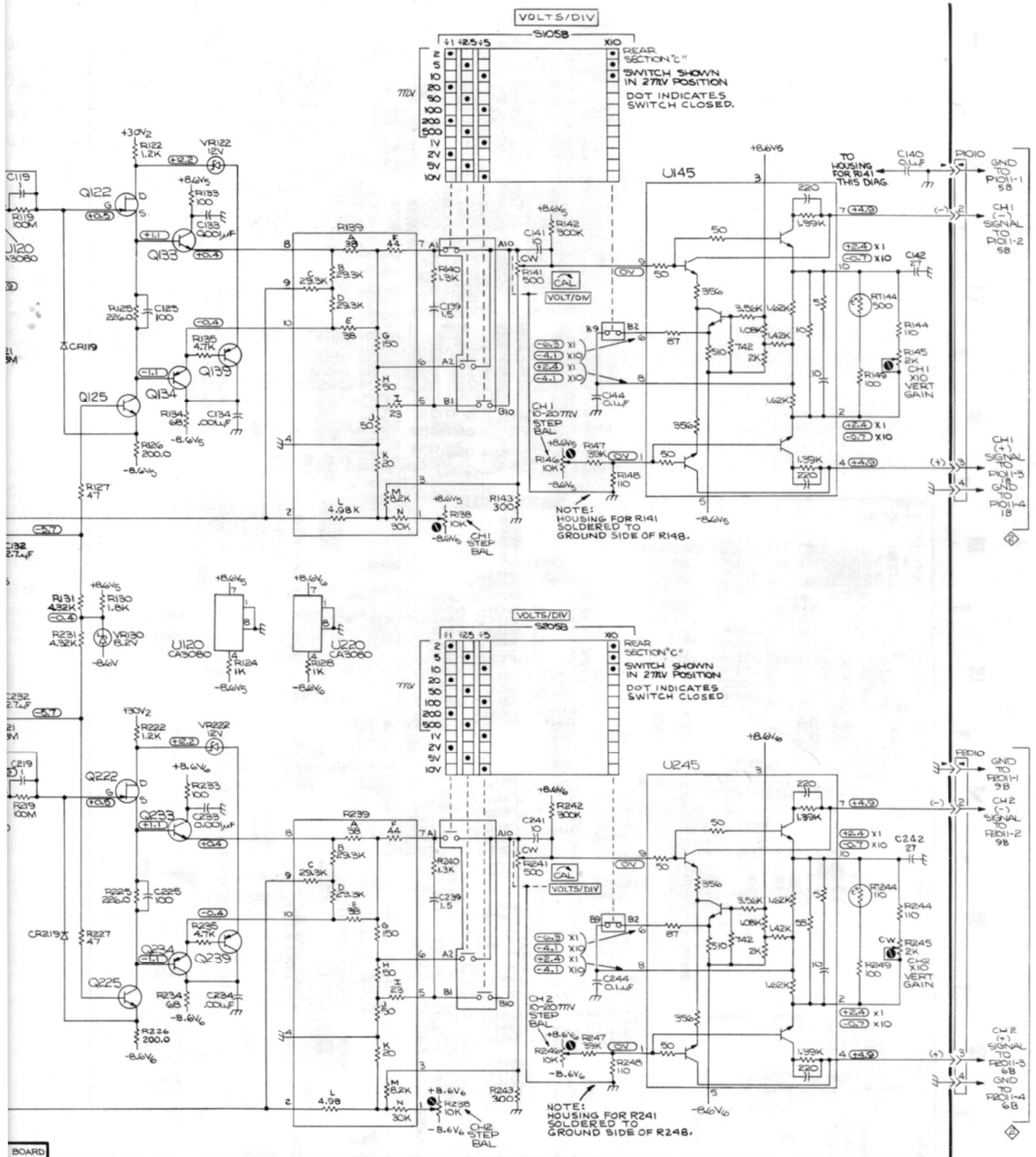

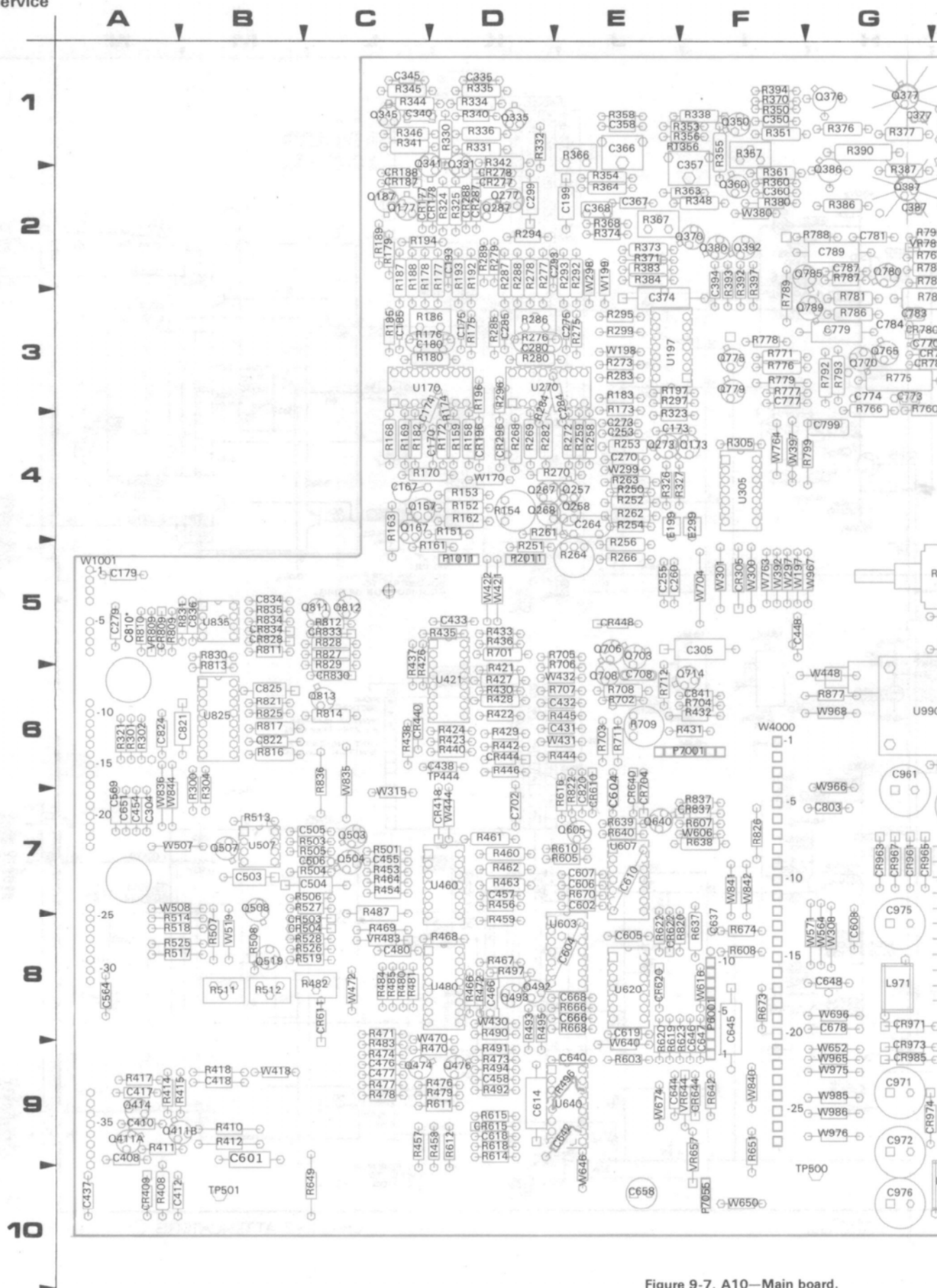
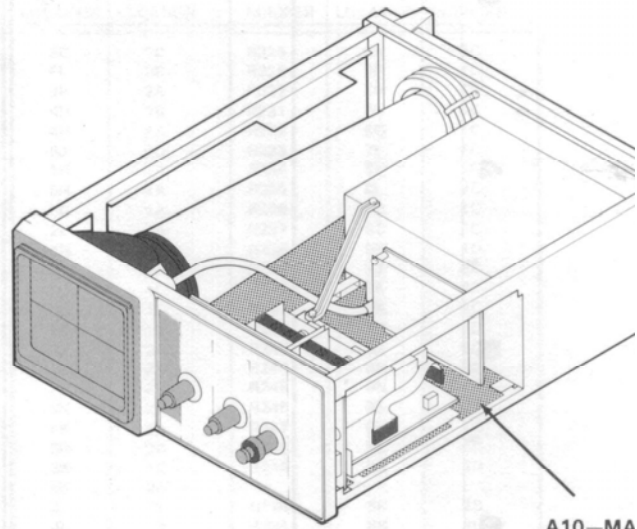
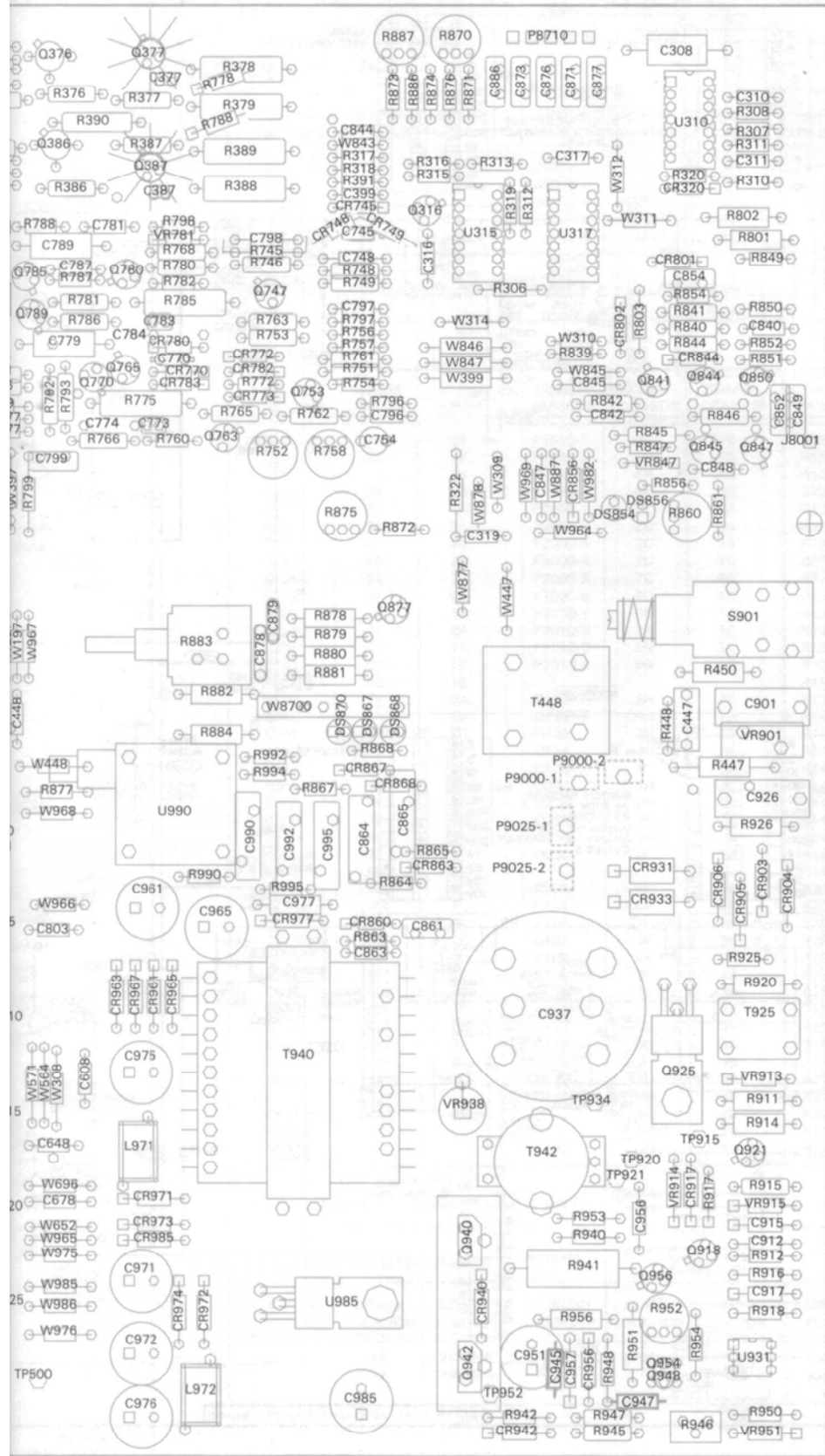

Figure 9-7. A10—Main board.



A10-MA

Static Sensitive Devices  
See Maintenance Section

COMPONENT NUMBER EXAMPLE

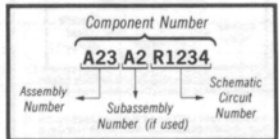

Chassis-mounted components have no Assembly Number prefix—see end of Replaceable Electrical Parts List.

\*See Parts serial num

board.

## A10—MAIN BOARD

CIRCUIT NUMBER	SCHEM NUMBER	CIRCUIT NUMBER	SCHEM NUMBER	CIRCUIT NUMBER	SCHEM NUMBER	CIRCUIT NUMBER	SCHEM NUMBER	CIRCUIT NUMBER	SCHEM NUMBER	CIRCUIT NUMBER	SCHEM NUMBER
C167	2	C610	5	C975	9	DS870	9	Q640	5	R270	2
C170	2	C614	4	C976	9	E199	2	Q703	7	R272	2
C173	2	C618	4	C977	9	E299	2	Q706	7	R273	2
C174	2	C619*	5	C985	9	L971	9	Q708	7	R275	2
C175	2	C637	5	C990	9	L972	9	Q714	7	R276	2
C179	2	C640	4	C992	9	P1011-1	2	Q747	7	R277	2
C180	2	C642	5	C995	9	P1011-2	2	Q753	7	R278	2
C185	2	C644	5	CR177	3	P1011-3	2	Q763	7	R279	2
C193	2	C645	5	CR178	3	P1011-4	2	Q765	7	R280	2
C199	2	C646	5	CR187	3	P2011-1	2	Q770	7	R282	2
C253	2	C647	5	CR188	3	P2011-2	2	Q775	7	R283	2
C255	2	C648	10	CR196	2	P2011-3	2	Q779	7	R284	2
C260	2	C651	10	CR277	3	P2011-4	2	Q780	7	R285	2
C264	2	C658	10	CR278	3	P6001-1	5	Q785	7	R286	2
C270	2	C666	5	CR287	3	P6001-2	10	Q789	7	R287	2
C273	2	C668	5	CR288	3	P6001-3	10	Q811	6	R288	2
C275	2	C678	3	CR296	2	P6001-4	5	Q812	6	R289	2
C279	2	C702	7	CR305	3	P6001-5	5	Q813	6	R292	2
C280	2	C708	7	CR320	3	P6001-6	5	Q841	6	R293	2
C284	2	C745	7	CR409	4	P6001-7	5	Q844	6	R294	2
C285	2	C748	7	CR418	4	P6001-8	10	Q845	6	R295	2
C293	2	C754	7	CR440	4	P6001-9	7	Q847	6	R296	2
C299	2	C770	7	CR444	4	P6001-10	7	Q850	6	R297	2
C304	3	C773	7	CR448	4	P7001-1	9	Q877	9	R299	2
C305	3	C774	7	CR503	4	P7001-2	9	Q918	9	R300	3
C308	3	C777	7	CR504	4	P7001-3	9	Q921	9	R301	3
C310	3	C779	7	CR610	5	P7001-4	9	Q925	9	R302	3
C311	3	C781	7	CR611	4	P7001-5	7	Q940	9	R304	3
C316	3	C783	7	CR615	4	P7001-6	7	Q942	9	R305	3
C317	3	C784	7	CR620	5	P7001-7	6	Q948	9	R306	3
C319	3	C787	7	CR622	5	P7055-1	10	Q954	9	R307	3
C335	3	C789	7	CR640	5	P7055-2	10	Q956	9	R308	3
C340	3	C796	7	CR644	5	P7055-3	10	R151	2	R310	3
C345	3	C797	7	CR704	3	P8710-1	9	R152	2	R311	3
C350	3	C798	7	CR745	7	P8710-2	9	R153	2	R312*	3
C357	3	C799	7	CR748	7	P8710-3	9	R154	2	R313*	3
C358	3	C803	6	CR749	7	P8710-4	9	R158	2	R315	3
C360	3	C810*	6	CR770	7	P8710-5	9	R159	2	R316	3
C366	3	C820	6	CR772	7	P9000-1	9	R161	2	R317	3
C367	3	C821	6	CR773	7	P9000-2	9	R162	2	R318	3
C368	3	C822	6	CR780	7	P9025-1	9	R163	2	R319	3
C374	3	C824	6	CR782	7	P9025-2	9	R168	2	R320	3
C377	3	C825	6	CR783	7	Q157	2	R169	2	R321	3
C387	3	C834	6	CR801	6	Q167	2	R170	2	R322	3
C394	3	C836	6	CR802	6	Q173	2	R172	2	R323	3
C399	3	C840	6	CR809	6	Q177	2	R173	2	R324	3
C408	4	C841	7	CR828	6	Q187	2	R174	2	R325	3
C410	4	C842	6	CR830	6	Q257	2	R175	2	R326	3
C412	4	C844	6	CR833	6	Q258	2	R176	2	R327	3
C417	4	C845	7	CR834	6	Q267	2	R177	2	R330	3
C418	4	C847	6	CR837	6	Q268	2	R178	2	R331	3
C431	4	C848	6	CR844	6	Q273	2	R179	2	R332	3
C432	4	C849	6	CR856	6	Q277	2	R180	2	R334	3
C433	4	C852	6	CR860	9	Q287	2	R182	2	R335	3
C437	4	C854	6	CR863	9	Q316	3	R183	2	R336	3
C438	4	C861	9	CR867	9	Q331	3	R185	2	R338	3
C447	9	C863	9	CR868	9	Q335	3	R186	2	R340	3
C448	9	C864	9	CR903	9	Q341	3	R187	2	R341	3
C454	4	C865	9	CR904	9	Q345	3	R188	2	R342	3
C455	4	C871	9	CR905	9	Q350	3	R189	2	R344	3
C457	4	C873	9	CR906	9	Q360	3	R192	2	R345	3
C458	4	C876	9	CR917	9	Q370	3	R193	2	R346	3
C466	4	C877	9	CR931	9	Q376	3	R194	2	R348	3
C476	4	C878	9	CR933	9	Q377	3	R196	2	R350	3
C477	4	C879	9	CR940	9	Q380	3	R197	2	R351	3
C480	4	C886	9	CR942	9	Q386	3	R250	2	R353	3
C503	4	C901	9	CR956	9	Q387	3	R251	2	R354	3
C504	4	C912	9	CR961	9	Q392	3	R252	2	R355	3
C505	4	C915	9	CR963	9	Q411	4	R253	2	R356	3
C506	4	C917	9	CR965	9	Q414	4	R254	2	R357	3
C564	10	C926	9	CR967	9	Q474	4	R256	2	R358	3
C569	10	C937	9	CR971	9	Q476	4	R258	2	R360	3
C602	5	C945*	9	CR972	9	Q492	4	R259	2	R361	3
C601	10	C947*	9	CR973	9	Q493	4	R261	2	R363	3
C603	6	C951	9	CR974	9	Q503	4	R262	2	R364	3
C604	5	C956	9	CR977	9	Q504	4	R263	2	R366	3
C605	6	C957	9	CR985	9	Q507	4	R264	2	R367	3
C606	5	C961	9	DS854	6	Q508	4	R266	2	R368	3
C607	5	C965	9	DS856	6	Q519	4	R268	2	R370	3
C608	10	C971	9	DS867	9	Q605	4	R269	2	R371	3
		C972	9	DS868	9						

TABLE (CONT)



**A10—MAIN BOARD (CONT)**

CIRCUIT NUMBER	SCHEM NUMBER	CIRCUIT NUMBER	SCHEM NUMBER	CIRCUIT NUMBER	SCHEM NUMBER	CIRCUIT NUMBER	SCHEM NUMBER	CIRCUIT NUMBER	SCHEM NUMBER	CIRCUIT NUMBER	SCHEM NUMBER
R356	3	R483	4	R708	7	R852	6	U480	4	W854	6
R357	3	R484	4	R709	7	R856	6	U507	4	W877	9
R358	3	R485	4	R711	7	R860	9	U603	5	W878	9
R360	3	R487	4	R712	7	R861	9	U607	5	W887	9
R361	3	R490	4	R745	7	R863	9	U620	5	W964	9
R363	3	R491	4	R746	7	R864	9	U640A	4	W965	9
R364	3	R492	4	R748	7	R865	9	U640B	5	W966	9
R366	3	R493	4	R749	7	R867	9	U825	6	W967	7
R367	3	R494	4	R751	7	R868	9	U835	6	W968	9
R368	3	R495	4	R752	7	R870	9	U931	9	W969	7
R376	3	R496	4	R753	7	R871	9	U985	9	W975	9
R377	3	R497	4	R754	7	R872	9	U990	9	W976	9
R378	3	R501	4	R756	7	R873	9	VR483	4	W982	9
R379	3	R503	4	R757	7	R874	9	VR644	5	W985	9
R386	3	R504	4	R758	7	R875	9	VR648	5	W986	9
R387	3	R505	4	R760	7	R876	9	VR781	7	W1001-1	5
R388	3	R506	4	R761	7	R877	9	VR809	6	W1001-2	2
R389	3	R507	4	R762	7	R878	9	VR847	6	W1001-3	2
R390	3	R508	4	R763	7	R879	9	VR901	9	W1001-4	3
R391	3	R511	4	R765	7	R880	9	VR913	9	W1001-5	9
R408	4	R512	4	R766	7	R881	9	VR914	9	W1001-6	3
R410	4	R513	4	R768	7	R882	9	VR915	9	W1001-7	2
R411	4	R514	4	R771	7	R883	9	VR938	9	W1001-8	6
R412	4	R517	4	R772	7	R884	9	VR951	9	W1001-9	2
R414	4	R518	4	R775	7	R886	9	W170	2	W1001-10	2
R415	4	R519	4	R776	7	R887	9	W197	2	W1001-11	3
R417	4	R525	4	R777	7	R911	9	W198	2	W1001-12	3
R418	4	R526	4	R778	7	R912	9	W199	2	W1001-13	2
R421	4	R527	4	R779	7	R914	9	W297	2	W1001-14	9
R422	4	R528	4	R780	7	R915	9	W298	2	W1001-15	3
R423	4	R600	5	R781	7	R916	9	W299	2	W1001-16	3
R424	4	R601	5	R782	7	R917	9	W300	3	W1001-17	5
R426	4	R602	5	R785	7	R918	9	W301	3	W1001-18	5
R427	4	R603	5	R786	7	R920	9	W308	3	W1001-19	4
R428	4	R604	5	R787	7	R925	9	W309	3	W1001-20	4
R429	4	R605	4	R788	7	R926	9	W310	3	W1001-21	4
R430	4	R606	5	R789	7	R940	9	W311	3	W1001-22	4
R431	4	R607	5	R792	7	R941	9	W312	3	W1001-23	4
R432	4	R608	5	R793	7	R942	9	W314	3	W1001-24	4
R433	4	R610	4	R796	7	R945	9	W315	3	W1001-25	5
R435	4	R611	4	R797	7	R946	9	W399	7	W1001-26	5
R437	4	R612	4	R798	7	R947	9	W418	4	W1001-27	5
R438	4	R613	5	R799	7	R948	9	W421	4	W1001-28	5
R440	4	R614	4	R801	6	R950	9	W422	4	W1001-29	5
R442	4	R615	4	R802	6	R951	9	W430	4	W1001-30	5
R444	4	R616	6	R803	6	R952	9	W431	4	W1001-31	4
R445	4	R617	5	R809	6	R953	9	W432	4	W1001-32	9
R446	4	R618	4	R810	6	R954	9	W444	4	W1001-33	3
R447	9	R619	5	R811	6	R956	9	W447	9	W1001-34	3
R448	9	R620	5	R812	6	R990	9	W448	9	W1001-35	3
R450	9	R621	5	R813	6	R992	9	W470	4	W1001-36	4
R453	4	R622	5	R814	6	R994	9	W472	4	W1001-37	4
R454	4	R623	5	R816	6	R995	9	W507	4	W1001-38	4
R456	4	R624	5	R817	6	RT356	3	W508	4	W1001-39	4
R457	4	R632	5	R820	6	S901	9	W519	4	W4000-3	9
R458	4	R637	5	R821	6	T448	9	W600	5	W4000-23	9
R459	4	R638	5	R822	6	T925	9	W601	5	W4000-24	9
R460	4	R639	5	R823	6	T940	9	W606	5	W4000-25	9
R461	4	R640	5	R827	6	T942	9	W607	5	W4000-26	9
R462	4	R641	5	R828	6	TP444	4	W608	5	W8700-1	9
R463	4	R642	5	R829	6	TP500	9	W622	5	W8700-2	9
R464	4	R643	5	R830	6	TP501	9	W640	5	W8700-3	9
R466	4	R644	5	R831	6	TP915	9	W644	5	W8700-4	9
R467	4	R648	5	R834	6	TP920	9	W645	5	W8700-5	9
R468	4	R650	5	R835	6	TP921	9	W652	3	W8700-6	9
R469	4	R652	5	R836	6	TP934	9	W668	5	W8700-7	9
R470	4	R657	5	R837	6	TP940	9	W704	3	W8700-8	9
R471	4	R666	5	R839	6	TP952	9	W763	7		
R472	4	R668	5	R840	6	U170	2	W764	7		
R473	4	R670	5	R841	6	U197	2	W835	6		
R474	4	R701	7	R842	6	U197	3	W836	6		
R476	4	R702	7	R844	6	U270	2	W840	7		
R477	4	R703	7	R845	6	U305	3	W841	7		
R478	4	R704	7	R846	6	U310	3	W842	7		
R479	4	R705	7	R847	6	U315	3	W843	6		
R480	4	R706	7	R849	6	U317	3	W844	6		
R481	4	R707	7	R850	6	U421	4	W845	7		
R482	4			R851	6	U460	4	W846	7		
								W847	7		

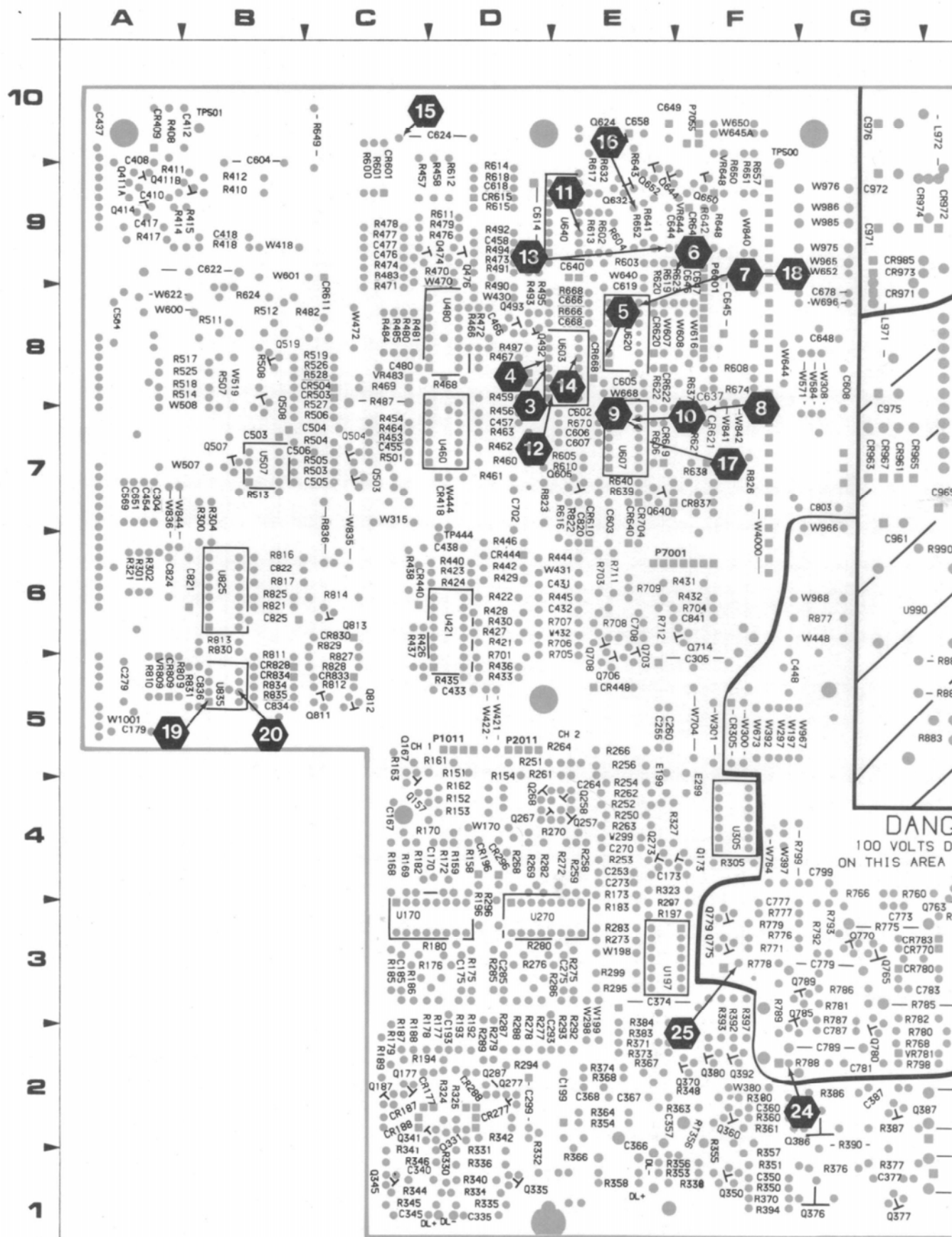

REV DEC 1981

Figure 9-8. Circuit v

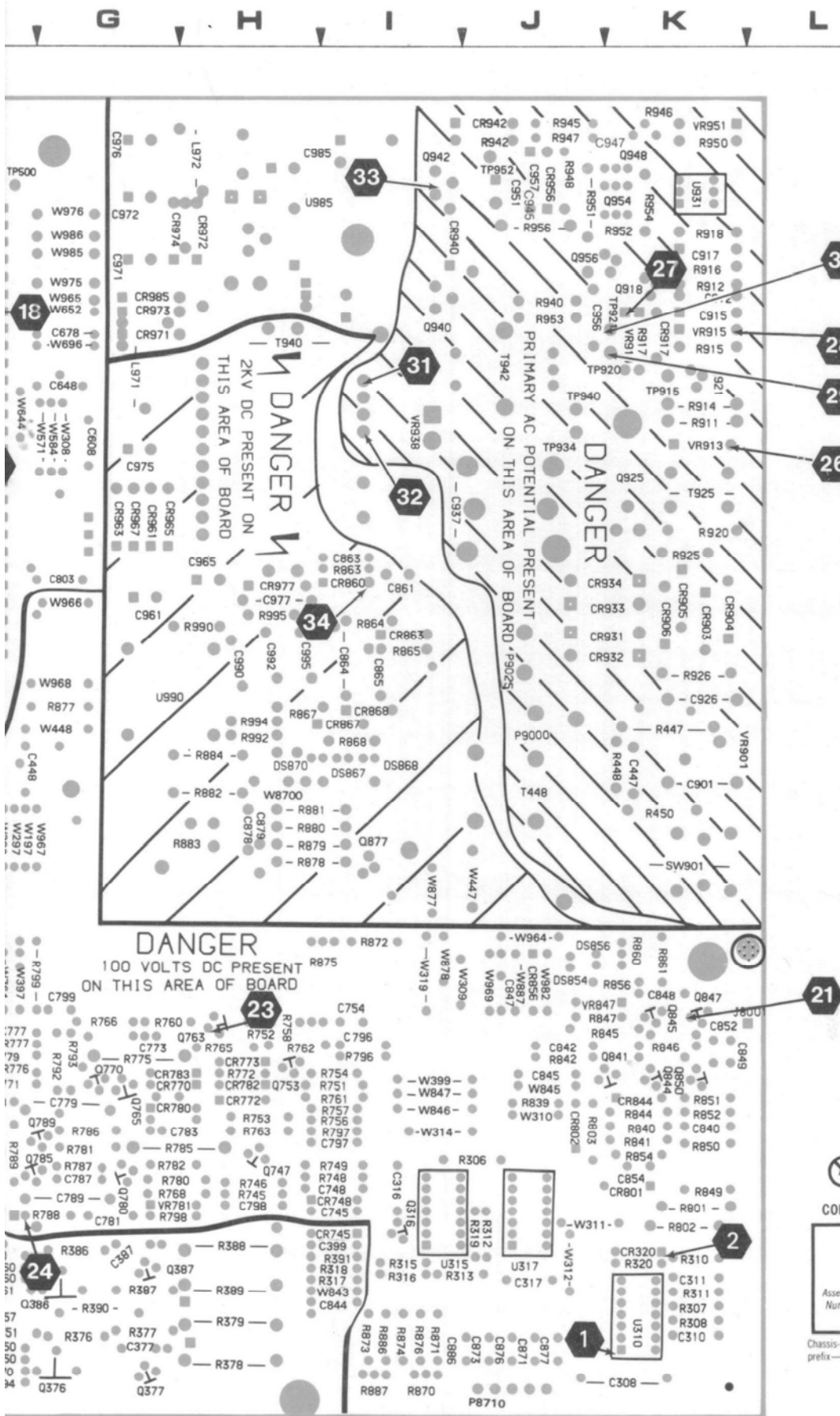

Static Sensitive Devices  
See Maintenance Section

**COMPONENT NUMBER EXAMPLE**

Component Number		
A23	A2	R1234
Assembly Number	Subassembly Number (if used)	Schematic Circuit Number

Chassis-mounted components have no Assembly Number prefix—see end of Replaceable Electrical Parts List.

Figure 9-8. Circuit view of A10—Main board.

## CH 1 & CH 2 VERTICAL PREAMPS



<b>ASSEMBLY A10</b>											
CIRCUIT NUMBER	SCHEM LOCATION	BOARD LOCATION	CIRCUIT NUMBER	SCHEM LOCATION	BOARD LOCATION	CIRCUIT NUMBER	SCHEM LOCATION	BOARD LOCATION	CIRCUIT NUMBER	SCHEM LOCATION	BOARD LOCATION
C167	2F	4C	Q157	1E	4C	R188	5L	2C	R292	7M	2E
C170	3F	4C	Q167	4E	4C	R189	5L	2C	R293	8M	2E
C173	3H	4F	Q173	3H	4F	R192	3M	2D	R294	7L	2D
C174	3J	4C	Q177	1L	2C	R193	3M	2D	R295	5G	3E
C175	1J	3D	Q187	5L	2C	R194	3L	2C	R296	7I	3D
C179	3M	5A	Q257	6E	4E	R196	4I	3D	R297	5G	3E
C180	3F	3C	Q258	7D	4E	R197	5G	3E	R299	5G	3E
C185	5I	3C	Q267	9E	4D	R250	7E	4E			
C193	3L	2D	Q268	8D	4D	R251	6C	5D	U170A	3I	3C
C199	3C	2E	Q273	7H	4E	R252	6C	4E	U170B	4I	3C
C253	8E	4E	Q277	6L	2D	R253	7D	4E	U170C	2I	3C
C255	7B	5E	Q287	9L	2D	R254	7D	4E	U170D	1F	3C
C260	8B	5E				R256	7C	5E	U170E	5F	3C
C264	7C	4E	R151	1C	4D	R258	7F	4E	U197A	5G	3E
C270	7F	4E	R152	2D	4D	R259	7F	4E	U197B	5H	3E
C273	7H	4E	R153	3E	4D	R261	9C	5D	U197D	5H	3E
C275	6I	3E	R154	3D	4D	R262	9C	4E	U197E	5H	3E
C279	8M	5A	R158	2F	4D	R263	8C	4E	U270A	7I	3D
C280	8F	3D	R159	2F	4D	R264	7D	5E	U270B	9I	3D
C284	7J	3E	R161	5C	5D	R266	8C	5E	U270C	6I	3D
C285	9J	3D	R162	3D	4D	R268	8F	4D	U270D	6F	3D
C293	8L	2D	R163	3E	4C	R269	8F	4D	U270E	9F	3D
C299	4C	2D	R168	3F	4C	R270	8F	4D			
			R169	4F	4C	R272	6J	4E	W170	4C	4D
CR196	3I	4D	R170	3F	4C	R273	7H	3E	W197	3C	5F
CR296	7I	4D	R172	2J	4D	R275	6I	3E	W198	3C	3E
			R173	3H	4E	R276	6K	3D	W199	3C	2E
E199	3C	4E	R174	2J	3D	R277	6L	2D	W297	4C	5F
E299	4C	4F	R175	1J	3D	R278	6L	2D	W298	4C	2E
			R176	2L	3C	R279	5L	2D	W299	4C	4E
P1011-1	5B	5D	R177	1L	2D	R280	8F	3D	W1001-2	5M	5A
P1011-2	4B	5D	R178	1L	2C	R282	8I	4D	W1001-3	1M	5A
P1011-3	1B	5D	R179	1L	2C	R283	7F	3E	W1001-7	7B	5A
P1011-4	1B	5D	R180	3F	3C	R284	7J	4D	W1001-9	5M	6A
P2011-1	9B	5D	R182	4I	4C	R285	9J	3D	W1001-10	9M	6A
P2011-2	9B	5D	R183	4G	3E	R286	8K	3D	W1001-13	8B	6A
P2011-3	6B	5D	R185	5I	3C	R287	9L	2D			
P2011-4	6B	5D	R186	3K	3C	R288	9L	2D			
			R187	5L	2C	R289	9L	2D			

*Partial A10 also shown on diagrams 3, 4, 5, 6, 7, 9 and 10.*

<b>ASSEMBLY A11</b>											
CIRCUIT NUMBER	SCHEM LOCATION	BOARD LOCATION	CIRCUIT NUMBER	SCHEM LOCATION	BOARD LOCATION	CIRCUIT NUMBER	SCHEM LOCATION	BOARD LOCATION	CIRCUIT NUMBER	SCHEM LOCATION	BOARD LOCATION
C265	9B	1C	S264	8A	2C	W1000-2	5N	4A	W1000-10	9N	4B
R190	3N	1B	W264	7B	2B	W1000-3	1N	4A	W1000-13	8B	4B
R191	3N	1B	W265	8B	2C	W1000-7	7B	4A			
R290	7N	1C				W1000 9	5N	4B			
R291	7N	1C									

*Partial A11 also shown on diagrams 1, 3, 4, 5, 6, 7, 8, 9 and 10.*



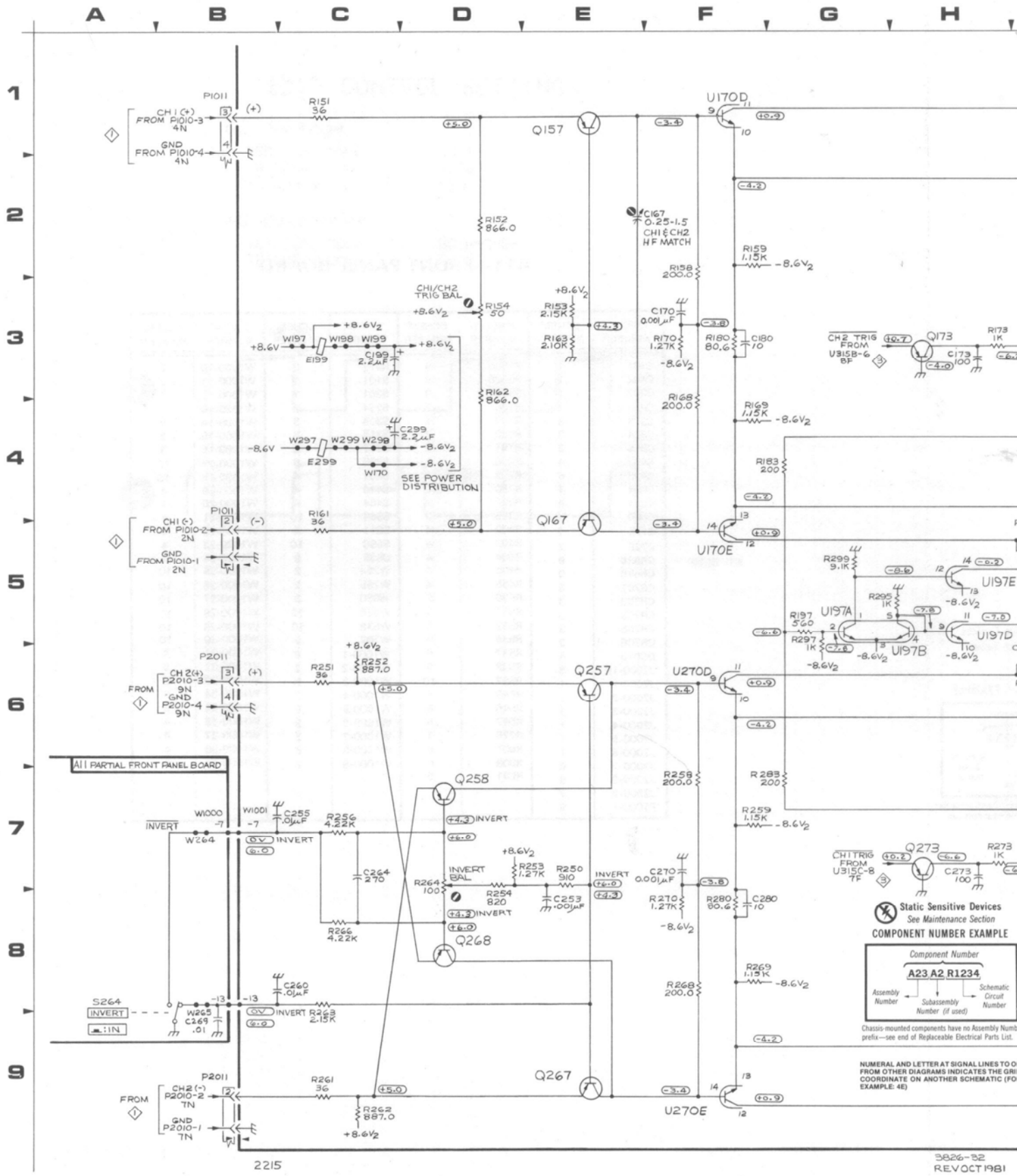

2215

3826-32  
REV OCT 1981

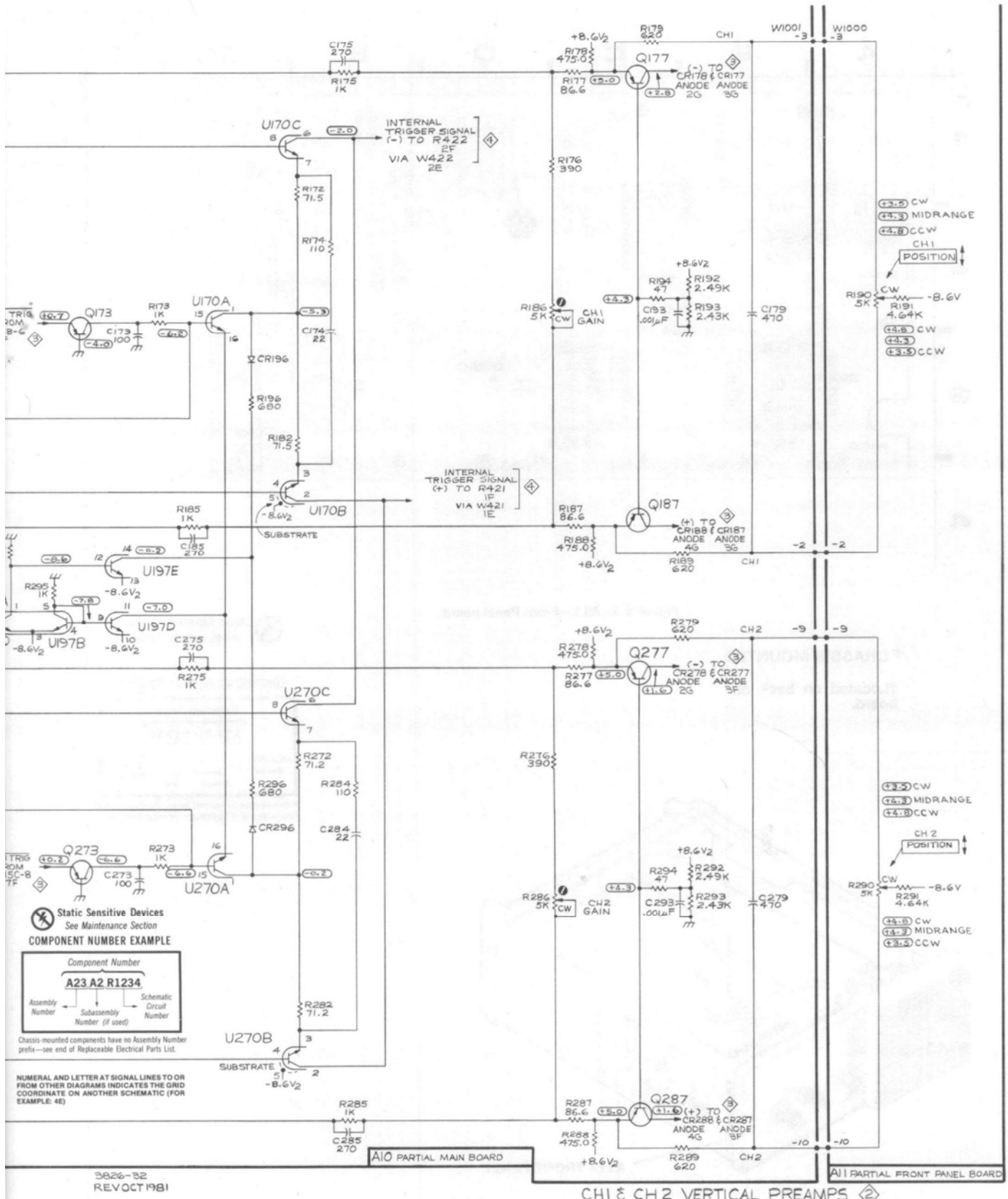

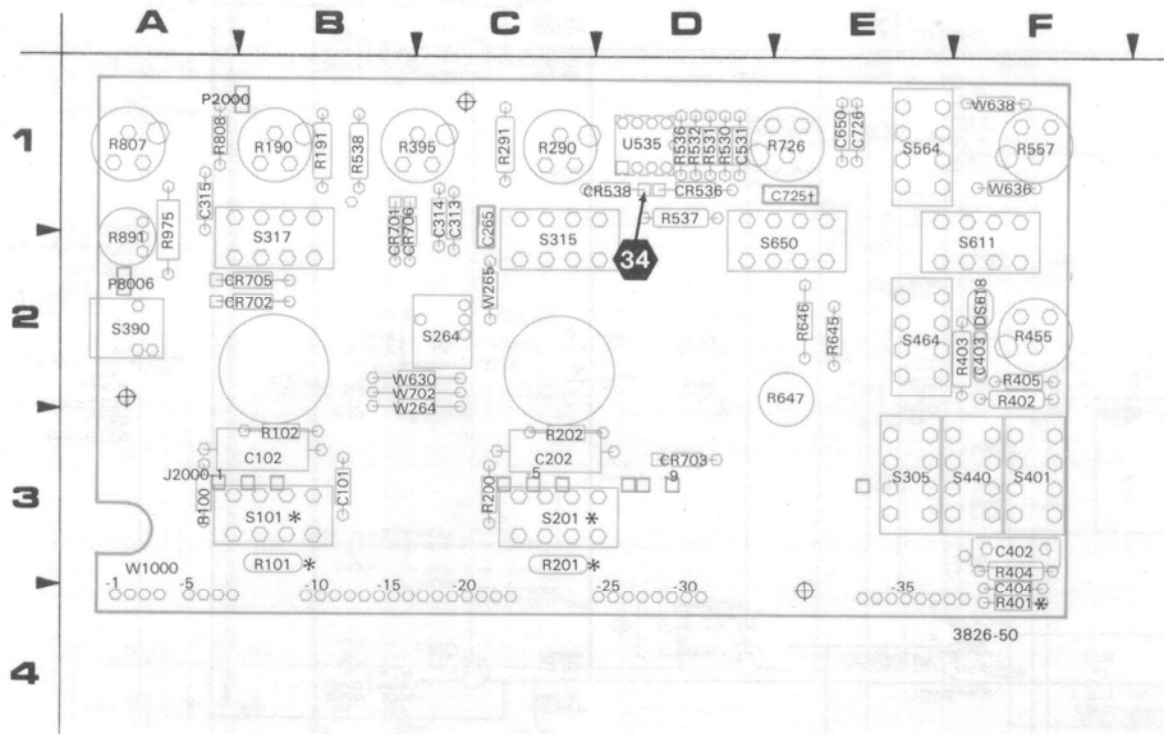

Figure 9-9. A11—Front Panel board.

\*CHASSIS MOUNTED

†Located on back of board.

 Static Sensitive Devices  
See Maintenance Section

COMPONENT NUMBER EXAMPLE

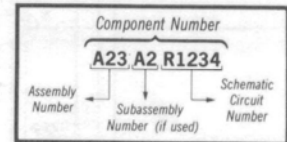

Chassis-mounted components have no Assembly Number prefix—see end of Replaceable Electrical Parts List.

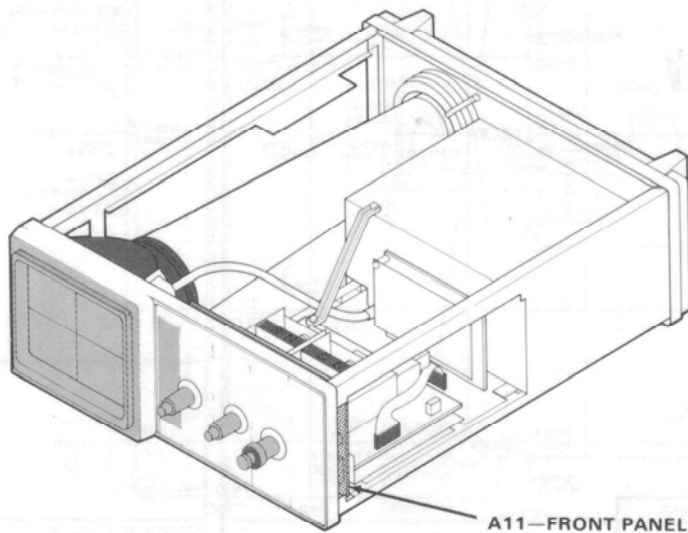

## A11—FRONT PANEL BOARD

CIRCUIT NUMBER	SCHEM NUMBER	CIRCUIT NUMBER	SCHEM NUMBER	CIRCUIT NUMBER	SCHEM NUMBER	CIRCUIT NUMBER	SCHEM NUMBER
C101	1	P1000-2	9	R975	9	W1000-10	2
C102	1	P8006-1	9	S101	1	W1000-11	3
C202	1	P8006-2	9	S201	1	W1000-12	3
C265	2	R100	1	S264	2	W1000-13	2
C313	3	R102	1	S305	3	W1000-14	9
C314	3	R190	2	S315	3	W1000-15	3
C315	3	R191	2	S317	3	W1000-16	3
C402	4	R200	1	S390	6	W1000-17	10
C403	4	R202	1	S401	4	W1000-18	10
C404	4	R290	2	S440	4	W1000-19	4
C531	9	R291	2	S464	4	W1000-20	4
C650	10	R395	3	S564	10	W1000-21	4
C725	7	R402	4	S611	4	W1000-22	4
C726	7	R403	4	S650	10	W1000-23	4
CR536	9	R404	4	U535	9	W1000-24	4
CR538	9	R405	4	W264	2	W1000-25	10
CR701	3	R455	4	W265	2	W1000-26	10
CR702	3	R630	9	W630	3	W1000-27	10
CR703	3	R531	9	W636	10	W1000-28	10
CR705	3	R532	9	W638	10	W1000-29	10
CR706	3	R536	9	W702	3	W1000-30	10
DS618	4	R537	9	W1000-1	6	W1000-31	4
J2000-10	5	R538	9	W1000-2	2	W1000-32	9
J2000-1	1	R557	10	W1000-3	2	W1000-33	3
J2000-2	1	R645	5	W1000-4	3	W1000-34	3
J2000-3	1	R646	5	W1000-5	9	W1000-35	3
J2000-4	1	R647	5	W1000-6	3	W1000-36	4
J2000-5	1	R726	7	W1000-7	2	W1000-37	4
J2000-6	1	R807	6	W1000-8	6	W1000-38	4
J2000-7	8	R808	6	W1000-9	2	W1000-39	4
J2000-8	8	R891	9				
J2000-9	7						
P1000-1	9						

REV OCT 1981

Tektronix 2215 Oscilloscope.max

## 2215 CONTROL SETTINGS

### DC Voltage

VERTICAL MODE	CH 1
TRIGGER MODE	AUTO
AC-GND-DC (both)	GND

### AC Waveforms

VERTICAL MODE	BOTH-CHOP
TRIGGER MODE	AUTO

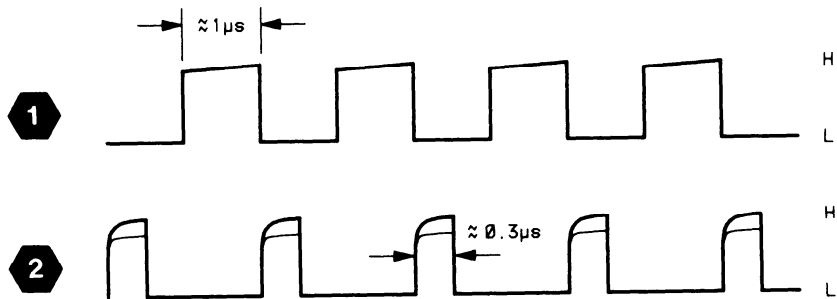

3826-14

# CHANNEL SWITCH & VERTICAL OUTPUT



<b>ASSEMBLY A10</b>											
CIRCUIT NUMBER	SCHEM LOCATION	BOARD LOCATION	CIRCUIT NUMBER	SCHEM LOCATION	BOARD LOCATION	CIRCUIT NUMBER	SCHEM LOCATION	BOARD LOCATION	CIRCUIT NUMBER	SCHEM LOCATION	BOARD LOCATION
C304	9C	7A	Q360	8L	2F	R342	3H	2D	U197C	5G	3E
C305	5C	5F	Q370	2N	2F	R344	2H	1C	U305A	5D	4F
C308	9E	1K	Q376	6N	1G	R345	2I	1C	U305B	7E	4F
C310	1H	1K	Q377	6N	1G	R346	2H	1C	U305C	8E	4F
C311	9E	2K	Q380	1M	2F	R348	8J	2F	U305D	8E	4F
C316	5G	2I	Q386	8N	2G	R350	6L	1F	U310A	3D	2K
C317	1G	2J	Q387	9N	2G	R351	6M	1F	U310B	8F	2K
C319	9G	4I	Q392	2M	2F	R353	7K	1F	U310C	8E	2K
C335	4I	1D				R354	7J	2E	U310D	8E	2K
C340	3H	1C	R300	7C	7B	R355	7L	1F	U315A	5F	2I
C345	2I	1C	R301	2D	6A	R356	7L	1F	U315B	8F	2I
C350	6L	1F	R302	4D	6A	R357	7L	1F	U315C	7F	2I
C357	7L	2F	R304	3D	7B	R358	7K	1E	U315D	9F	2I
C358	7K	2E	R305	5D	4F	R360	8L	2F	U317B	9D	2J
C360	9M	2F	R306	7E	3J	R361	9M	2F			
C366	8K	1E	R307	9E	1K	R363	8K	2F	W300	8D	5F
C367	8K	2E	R308	9D	1K	R364	8J	2E	W301	3D	5F
C368	7J	2E	R310	8E	2K	R366	7K	1E	W308	3C	8G
C374	1N	3E	R311	9F	2K	R367	7K	2E	W309	3D	4J
C377	5N	1G	R312*	4F	2J	R368	7J	2E	W310	3D	3J
C387	9N	2G	R313*	5F	2J	R370	2N	1F	W311	3D	2J
C394	1L	3F	R315	5F	2I	R371	2N	2E	W312	9D	2J
C399	7N	2I	R316	5G	2I	R373	1N	2E	W314	1G	3I
C678	1D	8G	R317	3E	2I	R374	1M	2E	W315	5C	7C
			R318	3E	2I	R376	6N	1G	W380	2M	2F
CR177	3G	2C	R319	9G	2J	R377	5N	1G	W392	2K	5F
CR178	2G	2C	R320	8G	2K	R378	6N	1H	W397	2L	4F
CR187	3G	2C	R321	8C	6A	R379	6N	1H	W652	1C	9G
CR188	4G	2C	R322	9G	4I	R380	2M	2F	W704	5D	5F
CR277	3F	2D	R323	5G	4E	R383	1M	2E	W1001-4	1K	5A
CR278	2G	2C	R324	4G	2D	R384	1M	2E	W1001-6	5C	5A
CR287	3F	2D	R325	4G	2D	R386	9N	2G	W1001-11	4C	6A
CR288	4G	2D	R326	7G	4E	R387	9N	2G	W1001-12	8C	6A
CR305	7D	5F	R327	8G	4E	R388	8N	2H	W1001-15	1C	6A
CR320	9G	2K	R330	3H	1D	R389	8N	2H	W1001-16	2C	6A
CR704	6C	7E	R331	4H	1D	R390	8N	1G	W1001-33	7C	9A
			R332	3I	1D	R391	8N	2I	W1001-34	7C	9A
Q316	5G	2I	R334	4I	1D	R392	1L	2F	W1001-35	8C	9A
Q331	4H	2D	R335	4I	1D	R393	2M	2F	W4000-7	2K	7F
Q335	4H	1D	R336	4H	1D	R394	1L	1F	W4000-12	9G	8F
Q341	2H	2C	R338	6J	1F	R397	2L	2F			
Q345	2H	1C	R340	4H	1D						
Q350	6L	1F	R341	3H	1C	RT356	8L	1F			

Partial A10 also shown on diagrams 2, 4, 5, 6, 7, 9 and 10.

<b>ASSEMBLY A11</b>											
CIRCUIT NUMBER	SCHEM LOCATION	BOARD LOCATION	CIRCUIT NUMBER	SCHEM LOCATION	BOARD LOCATION	CIRCUIT NUMBER	SCHEM LOCATION	BOARD LOCATION	CIRCUIT NUMBER	SCHEM LOCATION	BOARD LOCATION
C313	2C	1C	CR705	4B	2B	S317	3A	2B	W1000-11	4C	4B
C314	1C	1C	CR706	2A	2B				W1000-12	8C	4B
C315	5B	1A				W630	5B	2B	W1000-15	1C	4B
			R395	1J	1B	W702	5B	2B	W1000-16	2C	4B
CR701	4A	2B				W1000-4	1K	4A	W1000-33	7C	4E
CR702	5B	2B	S305	9A	3E	W1000-6	5C	4A	W1000-34	7C	4E
CR703	6B	3D	S315	1A	2C				W1000-35	8C	4E

Partial A11 also shown on diagrams 1, 2, 4, 5, 6, 7, 8, 9 and 10.

<b>CHASSIS MOUNTED PARTS</b>											
CIRCUIT NUMBER	SCHEM LOCATION	BOARD LOCATION	CIRCUIT NUMBER	SCHEM LOCATION	BOARD LOCATION	CIRCUIT NUMBER	SCHEM LOCATION	BOARD LOCATION	CIRCUIT NUMBER	SCHEM LOCATION	BOARD LOCATION
DL350	5I	CHASSIS	R398	6N	CHASSIS	R399	9N	CHASSIS			

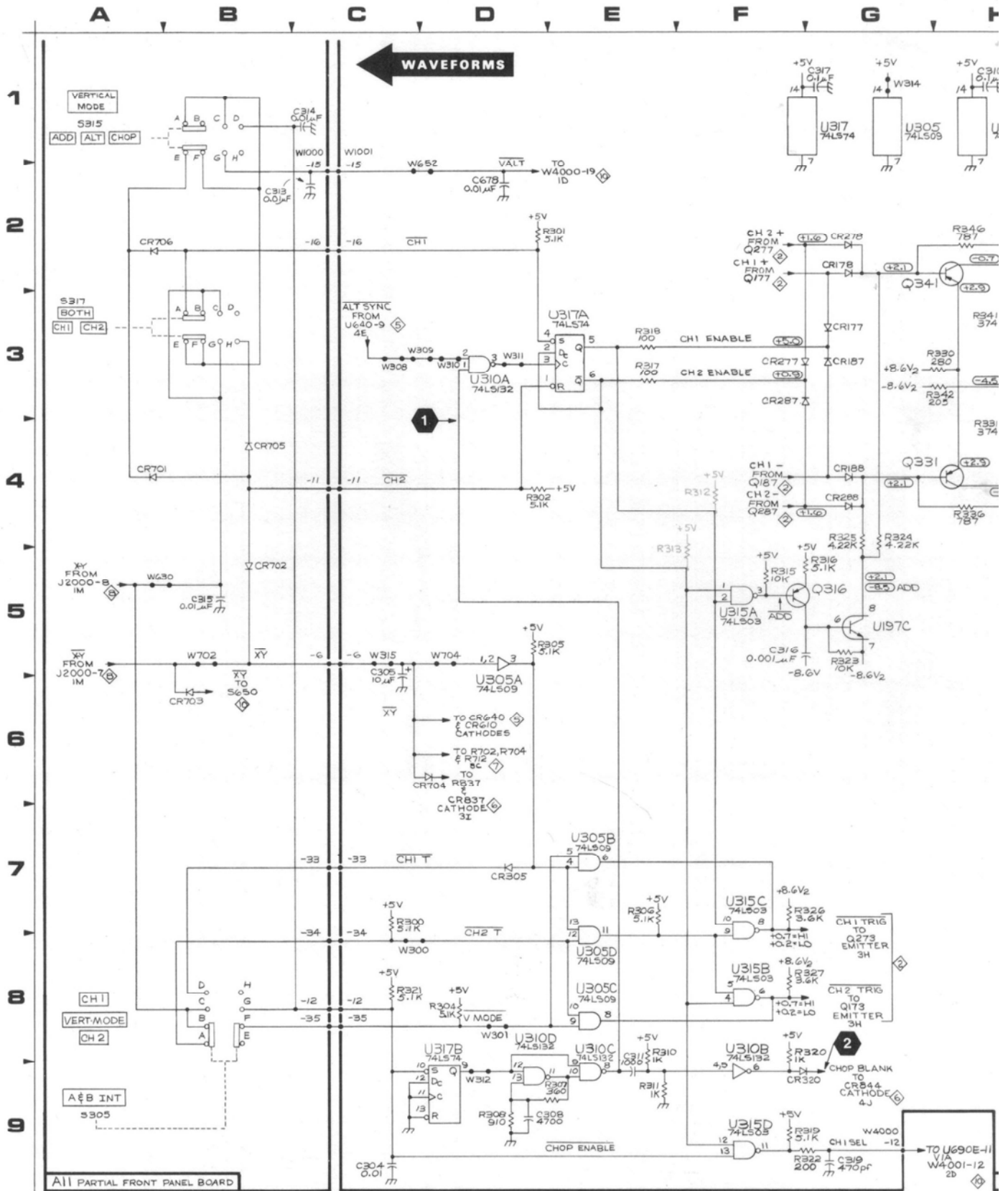

G H I J K L M N

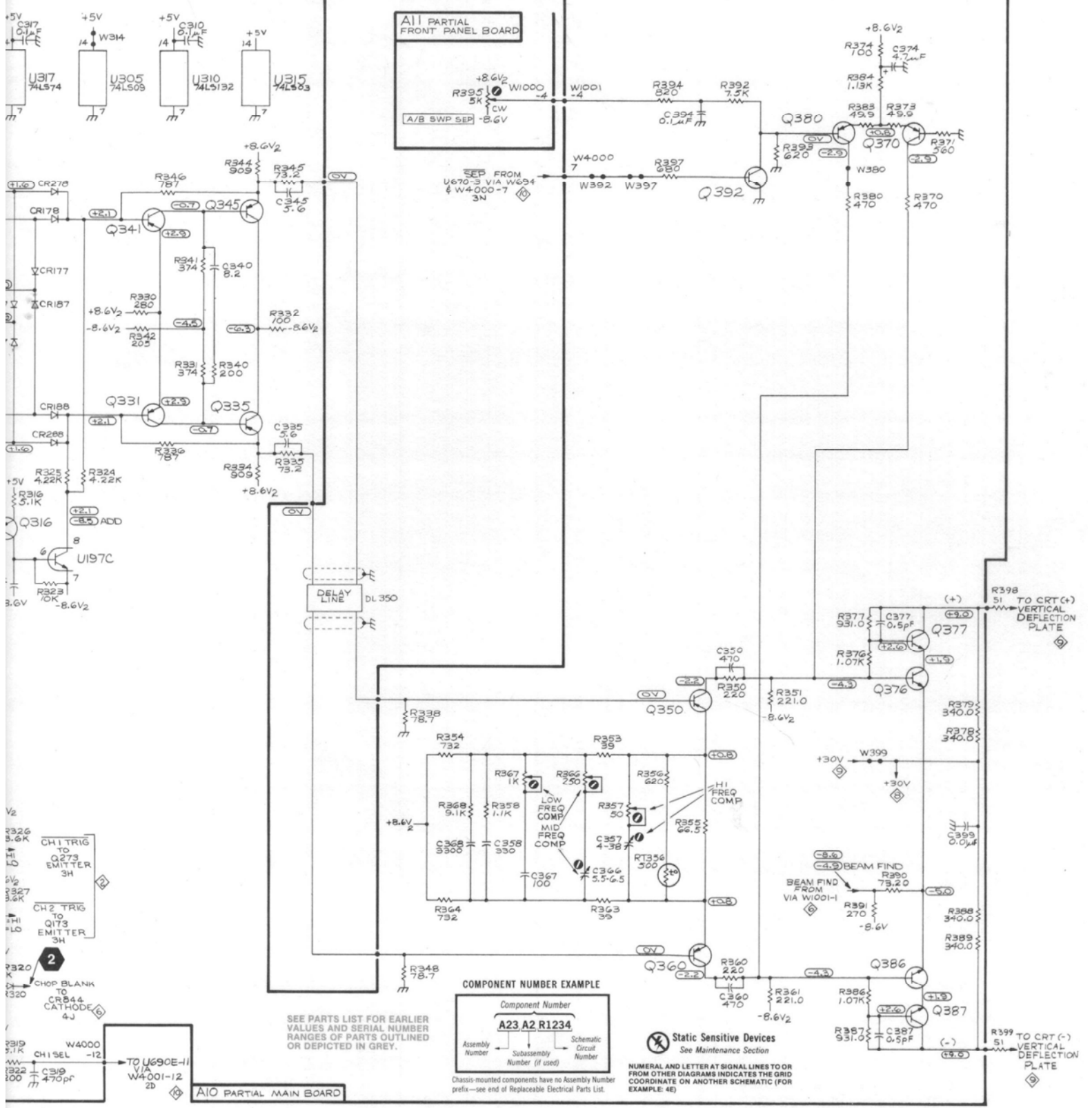

All PARTIAL FRONT PANEL BOARD

SEP FROM U670-3 VIA W694 & W4000-7 3N

SEE PARTS LIST FOR EARLIER VALUES AND SERIAL NUMBER RANGES OF PARTS OUTLINED OR DEPICTED IN GREY.

**COMPONENT NUMBER EXAMPLE**

Component Number		
A23	A2	R1234
Assembly Number	Subassembly Number (if used)	Schematic Circuit Number

Chassis-mounted components have no Assembly Number prefix—see end of Replaceable Electrical Parts List.

**Static Sensitive Devices**  
See Maintenance Section

NUMERAL AND LETTER AT SIGNAL LINES TO OR FROM OTHER DIAGRAMS INDICATES THE GRID COORDINATE ON ANOTHER SCHEMATIC (FOR EXAMPLE: 4E)

A10 PARTIAL MAIN BOARD

3826-33  
REV OCT 1981

CHANNEL SWITCH & VERTICAL OUTPUT



TRIGGER



ASSEMBLY A10											
CIRCUIT NUMBER	SCHEM LOCATION	BOARD LOCATION	CIRCUIT NUMBER	SCHEM LOCATION	BOARD LOCATION	CIRCUIT NUMBER	SCHEM LOCATION	BOARD LOCATION	CIRCUIT NUMBER	SCHEM LOCATION	BOARD LOCATION
C408	1D	9A	Q605	6N	7E	R472	4J	8D	TP444	5H	6D
C410	1D	9A				R473	3J	9D			
C412	2D	10A	R408	2C	10A	R474	3I	9C	U421A	1G	6D
C417	5D	9A	R410	1D	9B	R476	3J	9D	U421B	2G	6D
C418	5E	9B	R411	2D	9A	R477	3J	9C	U421C	2F	6D
C431	7D	6E	R412	3D	9B	R478	3J	9C	U421D	2F	6D
C432	8D	6E	R414	2D	9A	R479	3K	9D	U421E	1F	6D
C433	1G	5D	R415	2D	9A	R480	4K	8C	U460A	5J	7D
C437	5D	10A	R417	5D	9A	R481	5K	8C	U460B	6J	7D
C438	5G	6D	R418	5E	9B	R482	4J	8C	U460C	5K	7D
C454	6K	7A	R421	1F	6D	R483	4I	9C	U460D	5I	7D
C455	6K	7C	R422	2F	6D	R484	4K	8C	U460E	6I	7D
C457	8D	7D	R423	2F	6D	R485	4K	8C	U460F	5I	7D
C458	7D	9D	R424	2F	6D	R487	9C	8C	U480A	4K	8D
C466	4I	8D	R426	3F	6C	R490	5L	9D	U480B	4K	8D
C476	3I	9C	R427	2G	6D	R491	3L	9D	U480C	4I	8D
C477	3J	9C	R428	2F	6D	R492	6L	9D	U480D	4K	8D
C480	9D	8C	R429	3G	6D	R493	4L	8D	U507A	7G	7B
C503	7F	7B	R430	1F	6D	R494	6L	9D	U507B	8G	7B
C504	8F	7C	R431	7D	6F	R495	4M	8D	U640A	6M	9E
C505	6G	7C	R432	8D	6F	R496	5L	9E			
C506	9G	7C	R433	1G	5D	R497	4K	8D	VR483	9C	8C
C614	5M	9D	R435	2H	5D	R501	5G	7C			
C618	7M	9D	R436	2H	5D	R503	7G	7C	W418	5E	9B
C640	9E	9E	R437	3G	6C	R504	9G	7C	W421	1E	5D
			R438	4G	6C	R505	7F	7C	W422	2E	5D
CR409	2C	10A	R440	4H	6D	R506	8F	7C	W430	5L	8D
CR418	5E	7D	R442	4H	6D	R507	8G	8B	W431	7D	6E
CR440	4H	6C	R444	5F	6E	R508	9G	8B	W432	8D	6E
CR444	5F	6D	R445	5F	6E	R511	8H	8B	W444	5G	7D
CR448	5E	5E	R446	5E	6D	R512	9H	8B	W470	4I	9C
CR503	7F	8C	R453	6K	7C	R513	7H	7B	W472	3D	8C
CR504	8F	8C	R454	5K	7C	R514	9H	8A	W507	7H	7A
CR611	5N	8C	R456	6I	7D	R517	8E	8A	W508	8H	8A
CR615	6M	9D	R457	8D	9C	R518	9E	8A	W519	9F	8B
			R458	7D	9C	R519	9F	8C	W1001-19	3C	7A
Q411A	1D	9A	R459	6J	8D	R525	7E	8A	W1001-20	7K	7A
Q411B	2D	9A	R460	5J	7D	R526	8F	8C	W1001-21	7K	7A
Q414	1D	9A	R461	5J	7D	R527	7F	8C	W1001-22	7J	7A
Q474	3I	9C	R462	5K	7D	R528	8F	8C	W1001-23	8J	7A
Q476	3J	9D	R463	5K	7D	R605	6N	7E	W1001-24	6C	7A
Q492	4L	8D	R464	6K	7C	R610	5N	7E	W1001-31	7N	8A
Q493	4L	8D	R466	4I	8D	R611	5N	9D	W1001-36	5C	9A
Q503	6F	7C	R467	4J	8D	R612	6N	9D	W1001-37	5C	9A
Q504	9F	7C	R468	4J	8D	R614	5M	9D	W1001-38	4C	9A
Q507	7H	7B	R469	4J	8C	R615	5M	9D	W1001-39	1C	9A
Q508	9H	8B	R470	3I	9C	R618	7M	9D			
Q519	9F	8B	R471	4I	9C						

Partial A10 also shown on diagrams 2, 3, 5, 6, 7, 9 and 10

ASSEMBLY A11											
CIRCUIT NUMBER	SCHEM LOCATION	BOARD LOCATION	CIRCUIT NUMBER	SCHEM LOCATION	BOARD LOCATION	CIRCUIT NUMBER	SCHEM LOCATION	BOARD LOCATION	CIRCUIT NUMBER	SCHEM LOCATION	BOARD LOCATION
C402	1A	3F	R403	2B	2F	S464	7K	2F	W1000-23	8J	4C
C403	2B	2F	R404	1C	3F	S611	3A	2F	W1000-24	6C	4D
C404	2C	4F	R405	3B	2F				W1000-31	7N	4D
			R455	8J	2F				W1000-36	5C	4E
DS618	7N	2F				W1000-19	3C	4C	W1000-37	5C	4E
						W1000-20	7K	4C	W1000-38	4C	4E
			S401	1B	3F	W1000-21	7K	4C	W1000-39	1C	4F
R402	2B	2F	S440	4B	3F	W1000-22	7J	4C			

Partial A11 also shown on diagrams 1, 2, 3, 5, 6, 7, 8, 9 and 10

CHASSIS MOUNTED PARTS											
CIRCUIT NUMBER	SCHEM LOCATION	BOARD LOCATION	CIRCUIT NUMBER	SCHEM LOCATION	BOARD LOCATION	CIRCUIT NUMBER	SCHEM LOCATION	BOARD LOCATION	CIRCUIT NUMBER	SCHEM LOCATION	BOARD LOCATION
C401	1A	CHASSIS	J4001	1A	CHASSIS	R401	1A	CHASSIS			

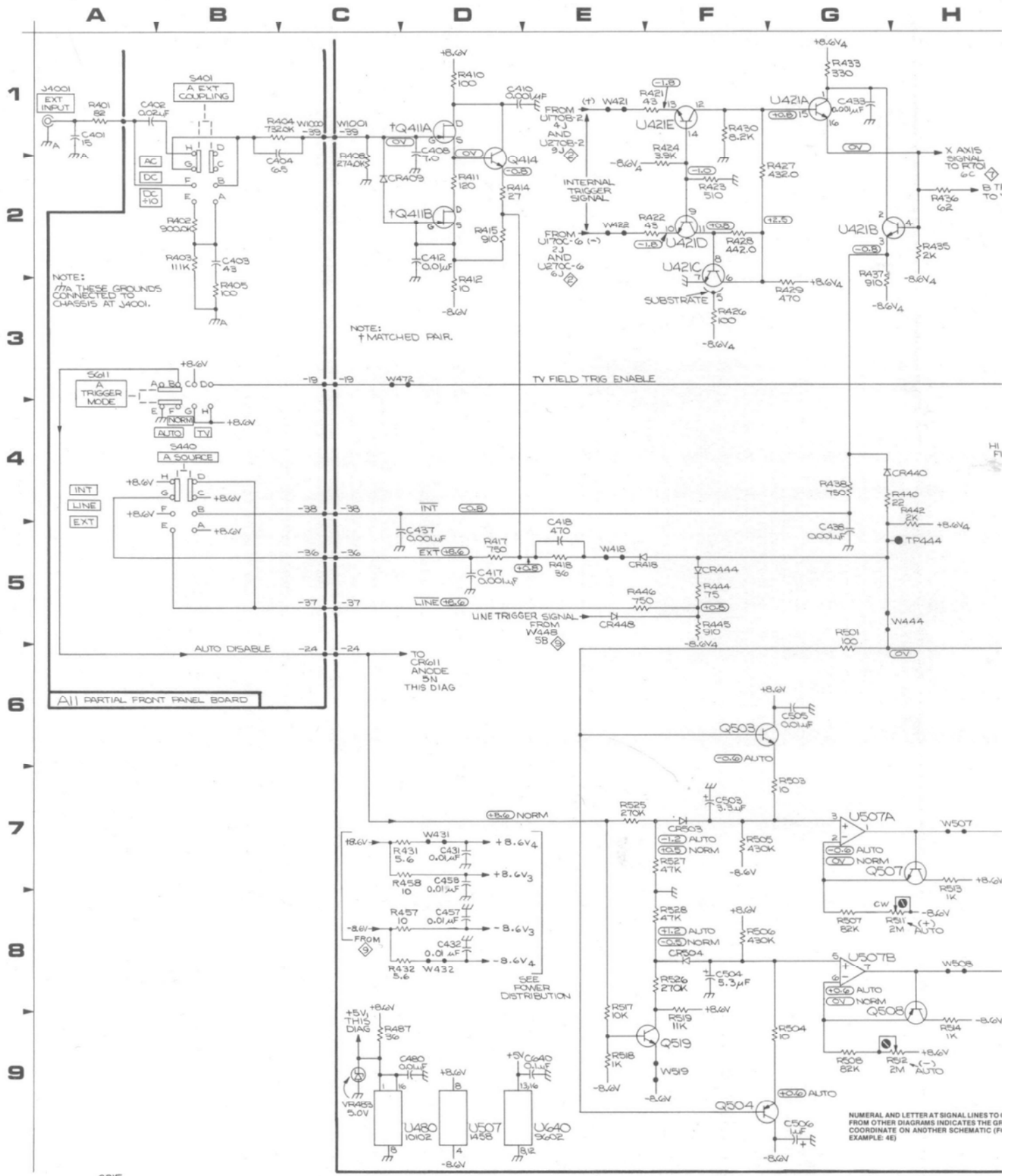

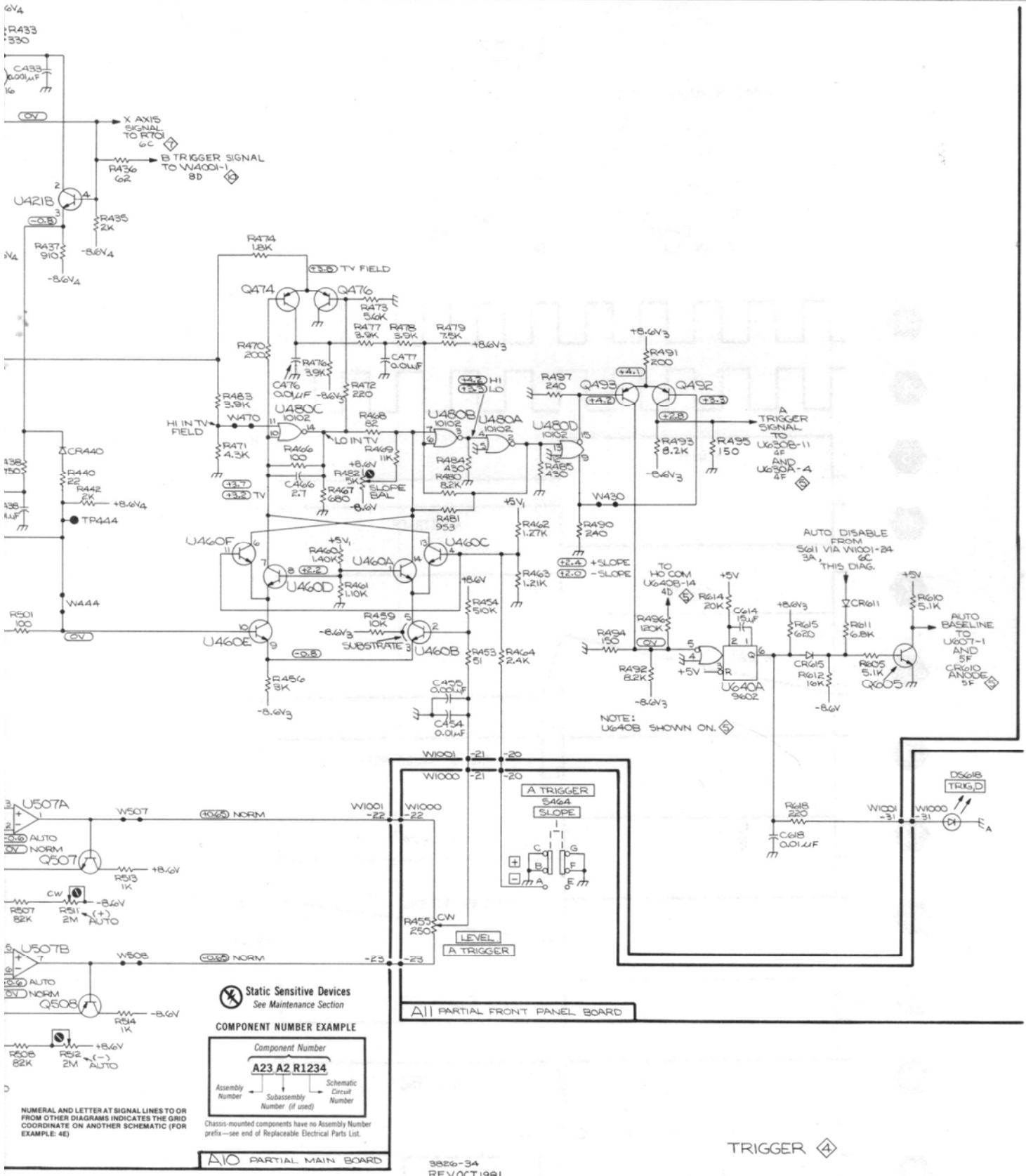

## 2215 CONTROL SETTINGS

### DC Voltages

HORIZONTAL MODE	A
A TRIGGER MODE	AUTO
AUTO INTENSITY	Midrange
A SEC/DIV	0.1 ms

### AC Waveforms

VERTICAL MODE	CH 1
HORIZONTAL MODE	A
A TRIGGER MODE	AUTO
A TRIGGER SOURCE	INT
A & B INT	CH 1
CH 1 VOLTS/DIV	1 V
A TRIGGER LEVEL	Midrange
CH 1 INPUT	1-kHz sine wave, 4V P-P
AC-GND-DC	DC

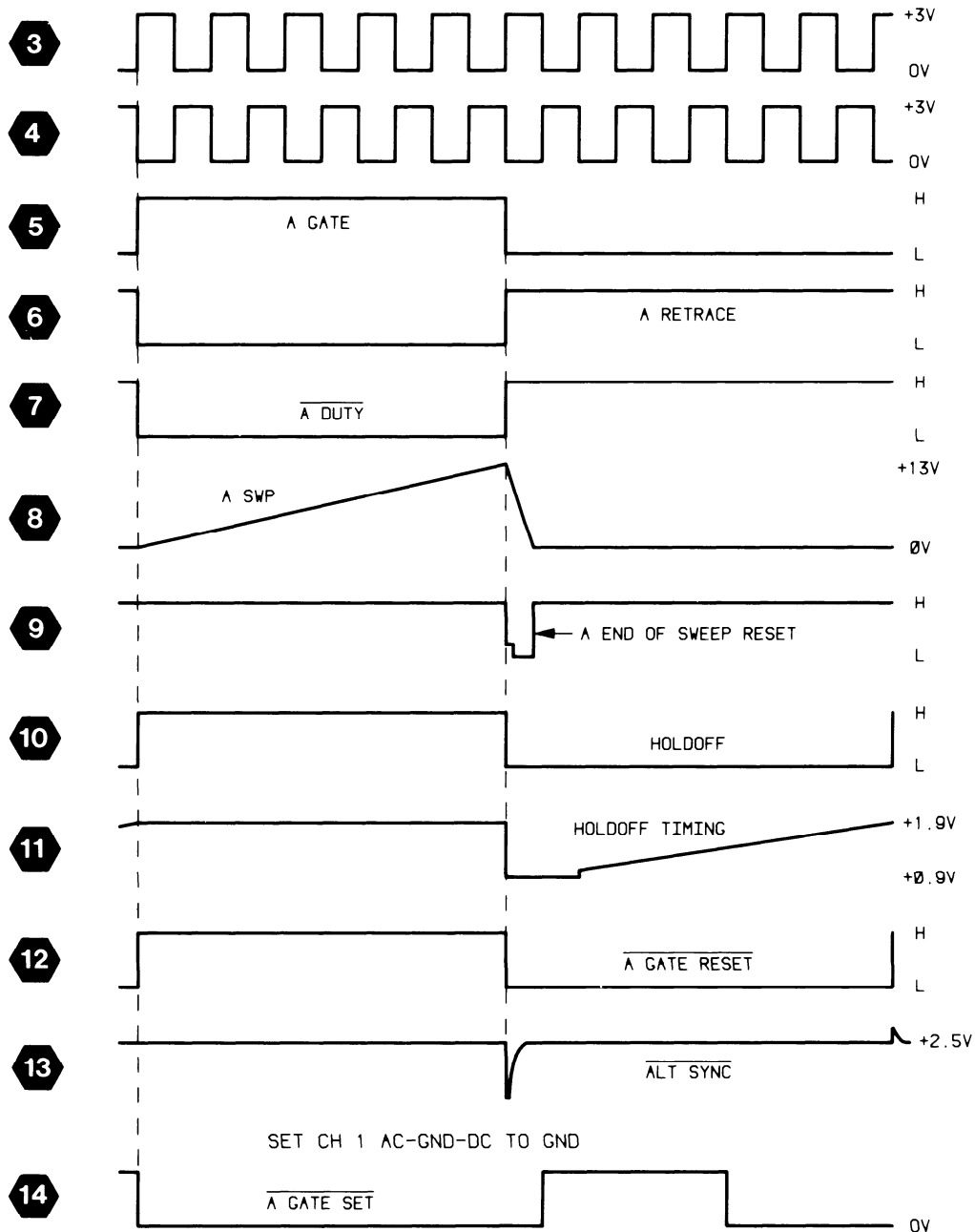

@

## SWEEP GENERATOR & LOGIC



<b>ASSEMBLY A10</b>								
CIRCUIT NUMBER	SCHEM LOCATION	BOARD LOCATION	CIRCUIT NUMBER	SCHEM LOCATION	BOARD LOCATION	CIRCUIT NUMBER	SCHEM LOCATION	BOARD LOCATION
C602	5D	7E	P6001-1	4I	8F	R668	4E	8E
C604	1G	7E	P6001-4	4L	8F	R670	5D	7E
C606	5C	7E	P6001-5	3B	8F			
C607	5C	7E	P6001-6	3B	8F	U603A	4D	8E
C610	1H	7E	P6001-7	3B	8F	U603B	4E	8E
C619	4H	8E				U607A	5D	7E
C637	5C	8F	Q640	5B	7E	U607B	5C	7E
C642	5B	9E				U607C	5C	7E
C644	3C	9E	R603	4E	9E	U607D	5G	7E
C645	4B	8F	R608	4F	8F	U620	4G	8E
C646	4B	9F	R619	4H	9E	U640B	5B	9E
C647	4B	9F	R620	4H	9E			
C666	4E	8E	R622	4H	8E	VR644	3C	9E
C668	4E	8E	R623	4H	9E			
			R637	5C	8F	W616	5F	8F
CR610	5D	7E	R638	5C	7F	W640	4B	9E
CR620	4H	8E	R639	5C	7E	W646	5F	10E
CR622	4H	8E	R640	4A	7E	W674	5D	9E
CR640	5A	7E	R642	3C	9F			
CR644	3C	9F	R666	4E	8E			
<i>Partial A10 also shown on diagrams 2, 3, 4, 6, 7, 9 and 10.</i>								
<b>ASSEMBLY A11</b>								
CIRCUIT NUMBER	SCHEM LOCATION	BOARD LOCATION	CIRCUIT NUMBER	SCHEM LOCATION	BOARD LOCATION	CIRCUIT NUMBER	SCHEM LOCATION	BOARD LOCATION
J2000-10	2B	3E	R645	1B	2E	R647	1A	2E
			R646	1B	2E			
<i>Partial A11 also shown on diagrams 1, 2, 3, 4, 6, 7, 8, 9 and 10.</i>								
<b>ASSEMBLY A12</b>								
CIRCUIT NUMBER	SCHEM LOCATION	BOARD LOCATION	CIRCUIT NUMBER	SCHEM LOCATION	BOARD LOCATION	CIRCUIT NUMBER	SCHEM LOCATION	BOARD LOCATION
C630	4K	4F	P6000-1	4J	4F	Q630B	4K	4F
C641	3K	4F	P6000-4	4L	3F	Q631	4K	4F
			P6000-5	3B	3F			
CR626	4J	4E	P6000-6	3B	3F	R630	4K	4F
CR630	3J	4F	P6000-7	3B	3F	R631	3L	2F
						R694	3K	4F
P2000-10	2B	4E	Q630A	4K	4F			
<i>Partial A12 also shown on diagrams 1, 7, 8 and 10.</i>								

**\*See Parts List for serial number ranges.**

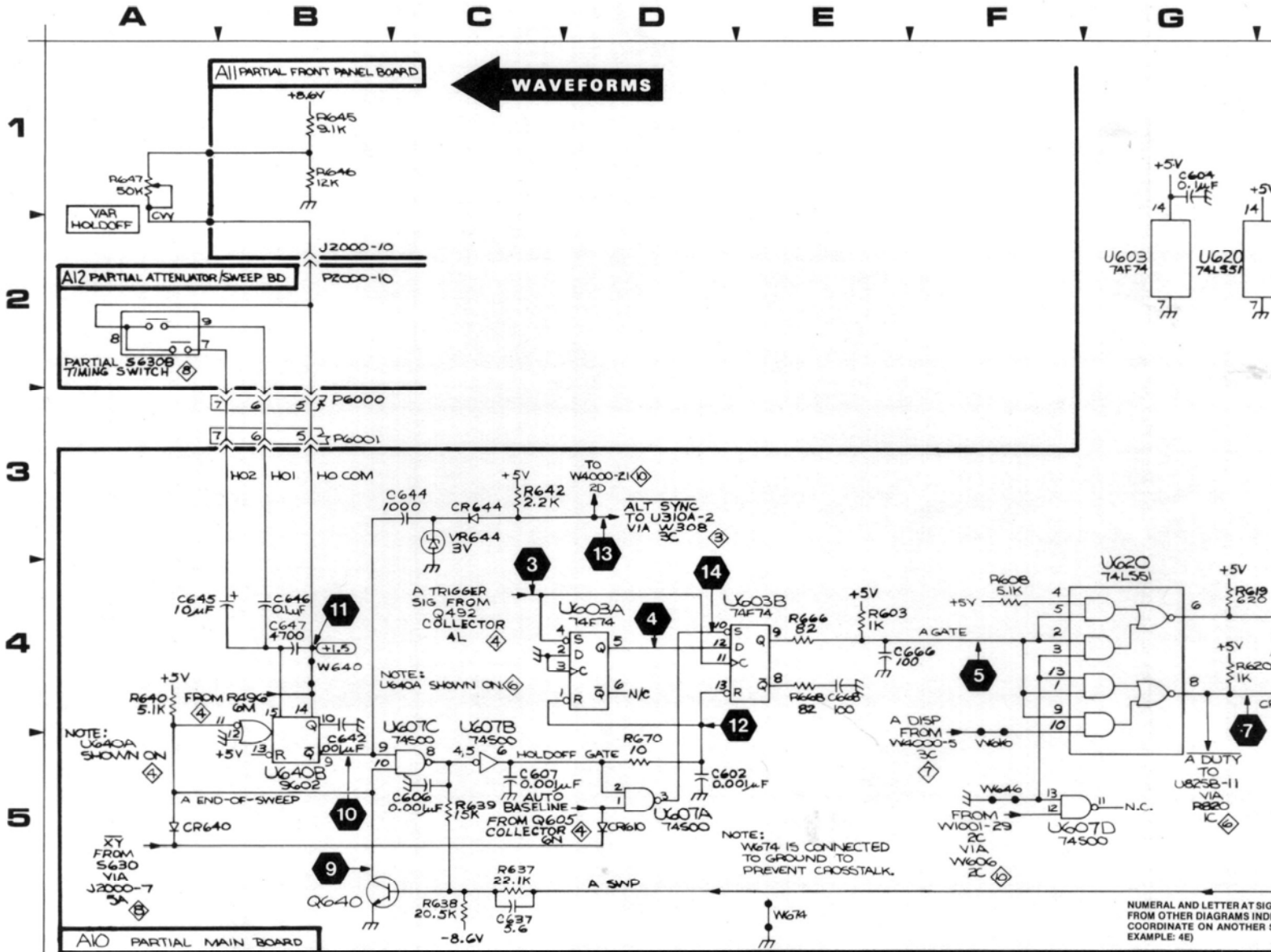

G H I J K L

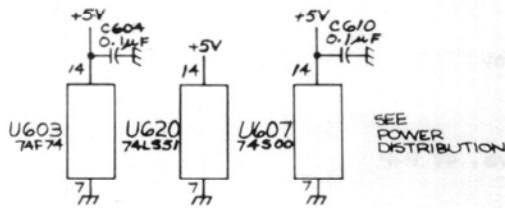

SEE POWER DISTRIBUTION

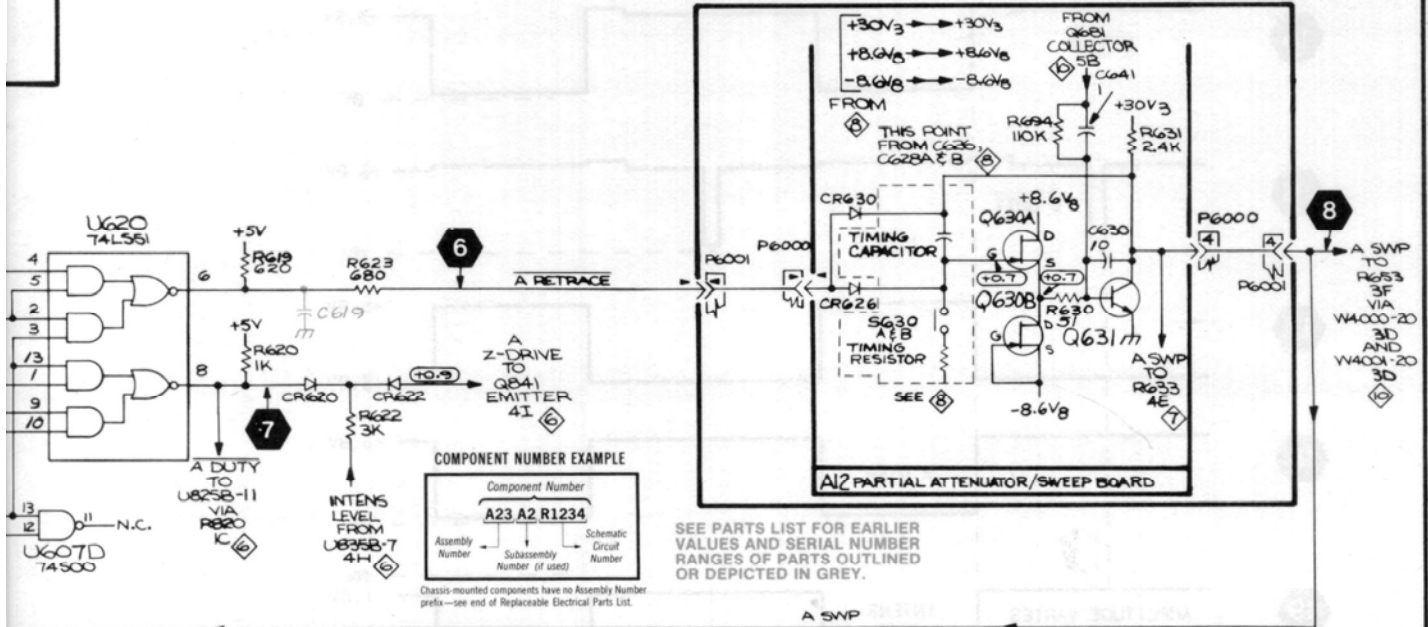

COMPONENT NUMBER EXAMPLE

Component Number		
A23	A2	R1234
Assembly Number	Subassembly Number (if used)	Schematic Circuit Number

Chassis mounted components have no Assembly Number prefix—see end of Replaceable Electrical Parts List.

SEE PARTS LIST FOR EARLIER VALUES AND SERIAL NUMBER RANGES OF PARTS OUTLINED OR DEPICTED IN GREY.

NUMERAL AND LETTER AT SIGNAL LINES TO OR FROM OTHER DIAGRAMS INDICATES THE GRID COORDINATE ON ANOTHER SCHEMATIC (FOR EXAMPLE: 4E)

⚡ Static Sensitive Devices See Maintenance Section

## 2215 CONTROL SETTINGS

### DC VOLTAGES

HORIZONTAL MODE	A
AUTO INTENSITY	Midrange
A SEC/DIV	0.1 ms
A TRIGGER MODE	AUTO
AC-GND-DC	GND

### AC Waveforms

HORIZONTAL MODE	ALT
A SEC/DIV	0.1 ms
B SEC/DIV	5 μs
A TRIGGER MODE	AUTO
AUTO INTEN	Visible display
A & B INT	CH 1
TRIGGER SOURCE	INT
CH 1 AC-GND-DC	DC
CH 1 INPUT	1-kHz sine wave, 4V P-P
B DELAY TIME POSITION	5.0
B TRIGGER LEVEL	RUN AFTER DLY

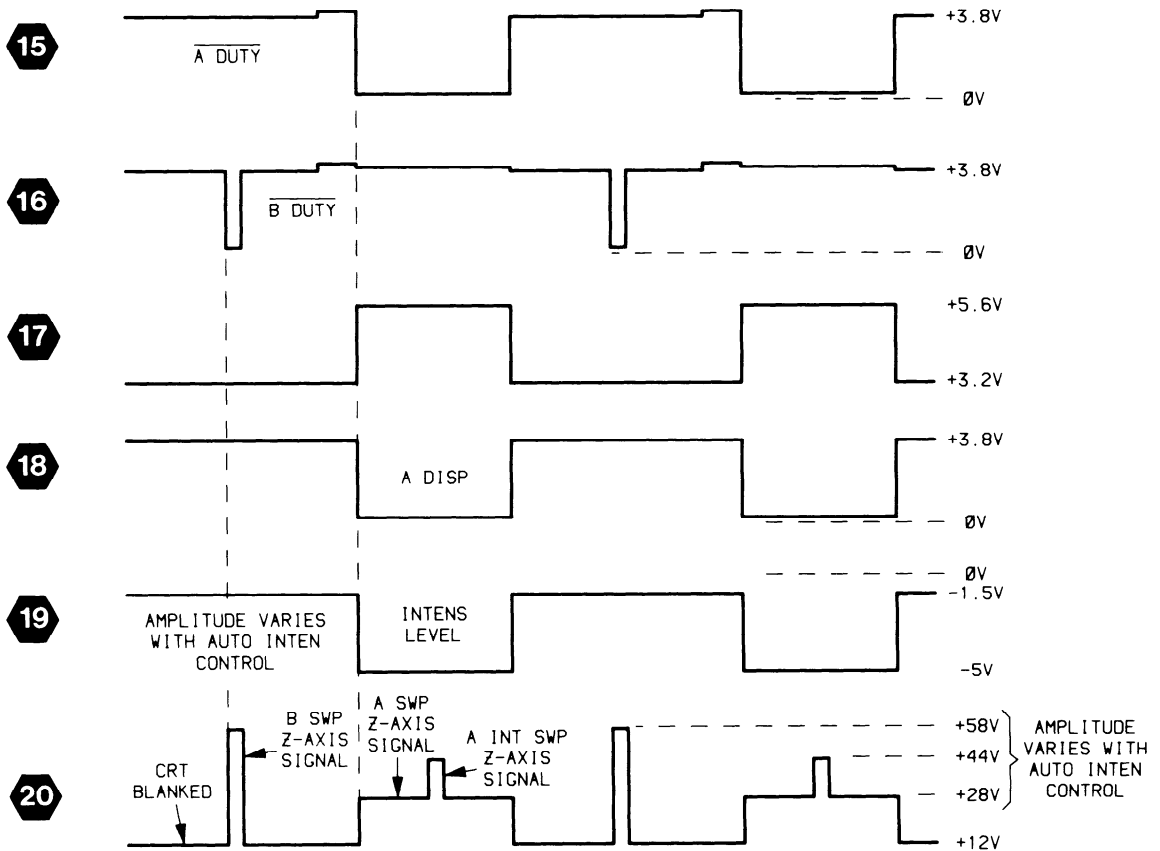

3826-12

@



## AUTO INTENSITY & Z AXIS



<b>ASSEMBLY A10</b>											
CIRCUIT NUMBER	SCHEM LOCATION	BOARD LOCATION	CIRCUIT NUMBER	SCHEM LOCATION	BOARD LOCATION	CIRCUIT NUMBER	SCHEM LOCATION	BOARD LOCATION	CIRCUIT NUMBER	SCHEM LOCATION	BOARD LOCATION
C603	8K	7E	CR837	3I	7F	R813	4F	6B	R849	4L	2K
C605	8L	8E	CR844	4J	3K	R814	3G	6C	R850	4L	3K
C803	6C	7G	CR856	5M	4J	R816	3E	6B	R851	4L	3K
C810*	5H	5A				R817	4E	6B	R852	4L	3K
C820	1C	7E	DS854	5M	4J	R820	1C	8E	R854*	4M	3K
C821	1D	6A	DS856	6M	4J	R821	1D	6B	R856	5M	4K
C822	1C	6B				R822	1C	7E			
C824	7N	6A	P7001-7	1C	6F	R825	3D	6B	U825A	3D	6B
C825	3D	6B				R826	3C	7F	U825B	1D	6B
C834	3H	5B	Q811	3G	5C	R827	3F	5C	U825C	2E	6B
C836	7M	5B	Q812	3F	5C	R828	2F	5C	U835A	2E	5B
C840	5J	3K	Q813	3F	6C	R829	2F	6C	U835B	4H	5B
C842	5I	3J	Q841	4I	3K	R830	2G	5B			
C844	6I	1I	Q844	5J	3K	R831	2F	5A	VR809	6G	5A
C847	8K	4J	Q845	6J	4K	R834	3H	5B	VR847	6L	4K
C848	6L	4K	Q847	6L	4K	R835	3H	5B			
C849	4L	3K	Q850	5L	3K	R836	4H	6C	W835	6M	6C
C852	5L	3K				R837	3I	7F	W836	8M	7A
C854	4M	2K	R616	2D	7E	R839	5I	3J	W843	6I	2I
			R801	7E	2K	R840	5J	3K	W844	7K	7A
CR801	7I	2K	R802	7G	2K	R841	5J	3K	W1001-1	8B	5A
CR802	7H	3J	R803	7I	3J	R842	5I	3J	W1001-8	6B	5A
CR809	6G	5A	R809	6H	5A	R844	4J	3K	W4000-8	1J	7F
CR828	2F	5B	R810	6H	5A	R845	6J	3K	W4000-9	6C	7F
CR830	2F	6C	R811	5G	5B	R846	5K	3K	W4000-18	3C	8F
CR833	4G	5C	R812	4F	5C	R847	5K	4K			
CR834	3H	5B									

*Partial A10 also shown on diagrams 2, 3, 4, 5, 7, 9 and 10.*

<b>ASSEMBLY A11</b>											
CIRCUIT NUMBER	SCHEM LOCATION	BOARD LOCATION	CIRCUIT NUMBER	SCHEM LOCATION	BOARD LOCATION	CIRCUIT NUMBER	SCHEM LOCATION	BOARD LOCATION	CIRCUIT NUMBER	SCHEM LOCATION	BOARD LOCATION
R807	6A	1A	S390	8A	2A	W1000-1	8B	4A			
R808	6A	1A				W1000-8	6B	4A			

*Partial A11 also shown on diagrams 1, 2, 3, 4, 5, 7, 8, 9 and 10.*

<b>CHASSIS MOUNTED PARTS</b>											
CIRCUIT NUMBER	SCHEM LOCATION	BOARD LOCATION	CIRCUIT NUMBER	SCHEM LOCATION	BOARD LOCATION	CIRCUIT NUMBER	SCHEM LOCATION	BOARD LOCATION	CIRCUIT NUMBER	SCHEM LOCATION	BOARD LOCATION
J8001	7C	CHASSIS									

**\*See Parts List for serial number ranges.**

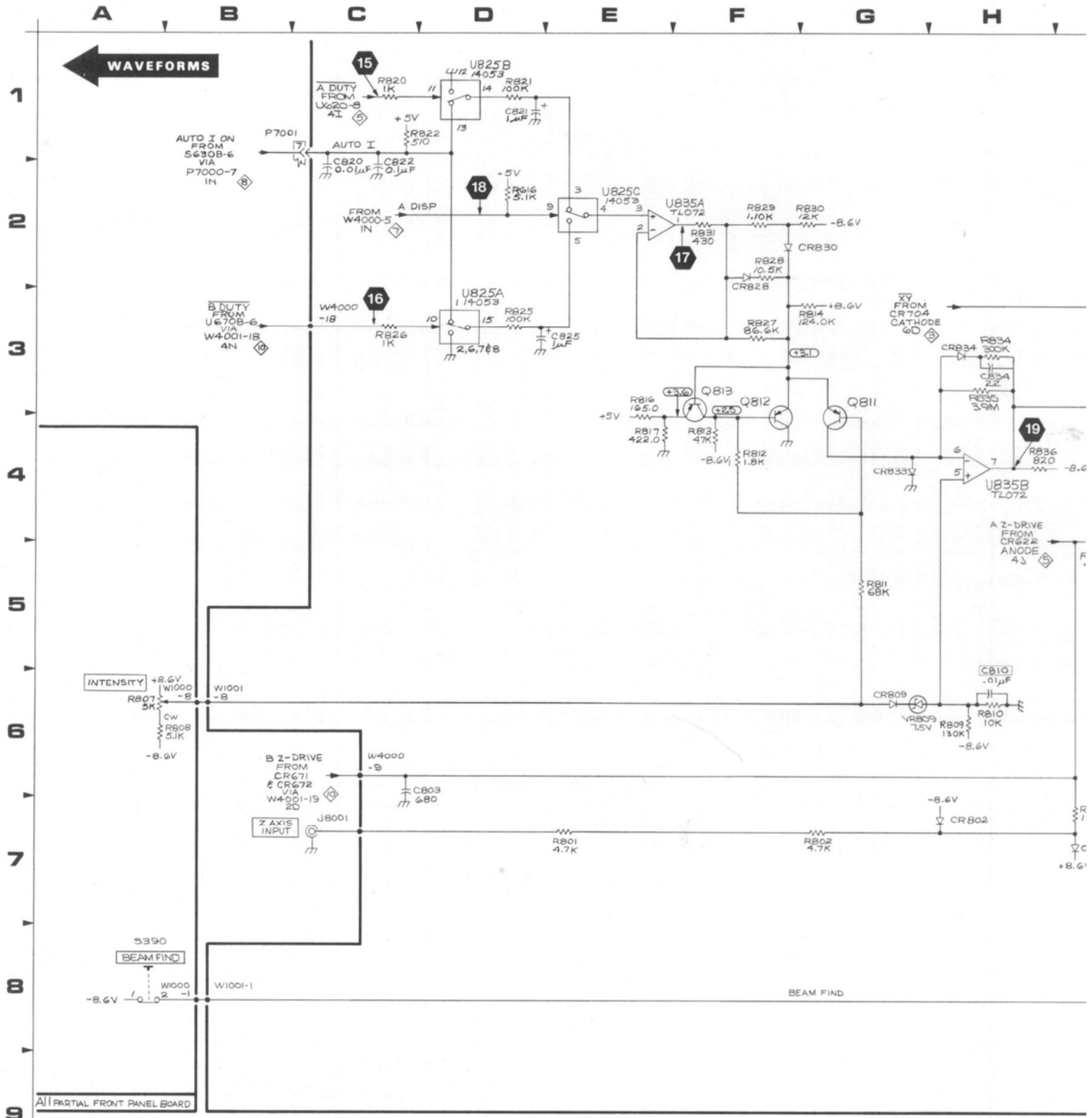

H I J K L M N

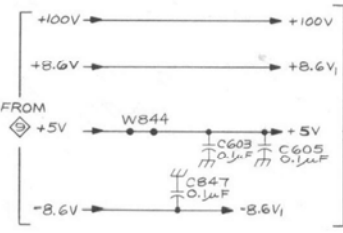
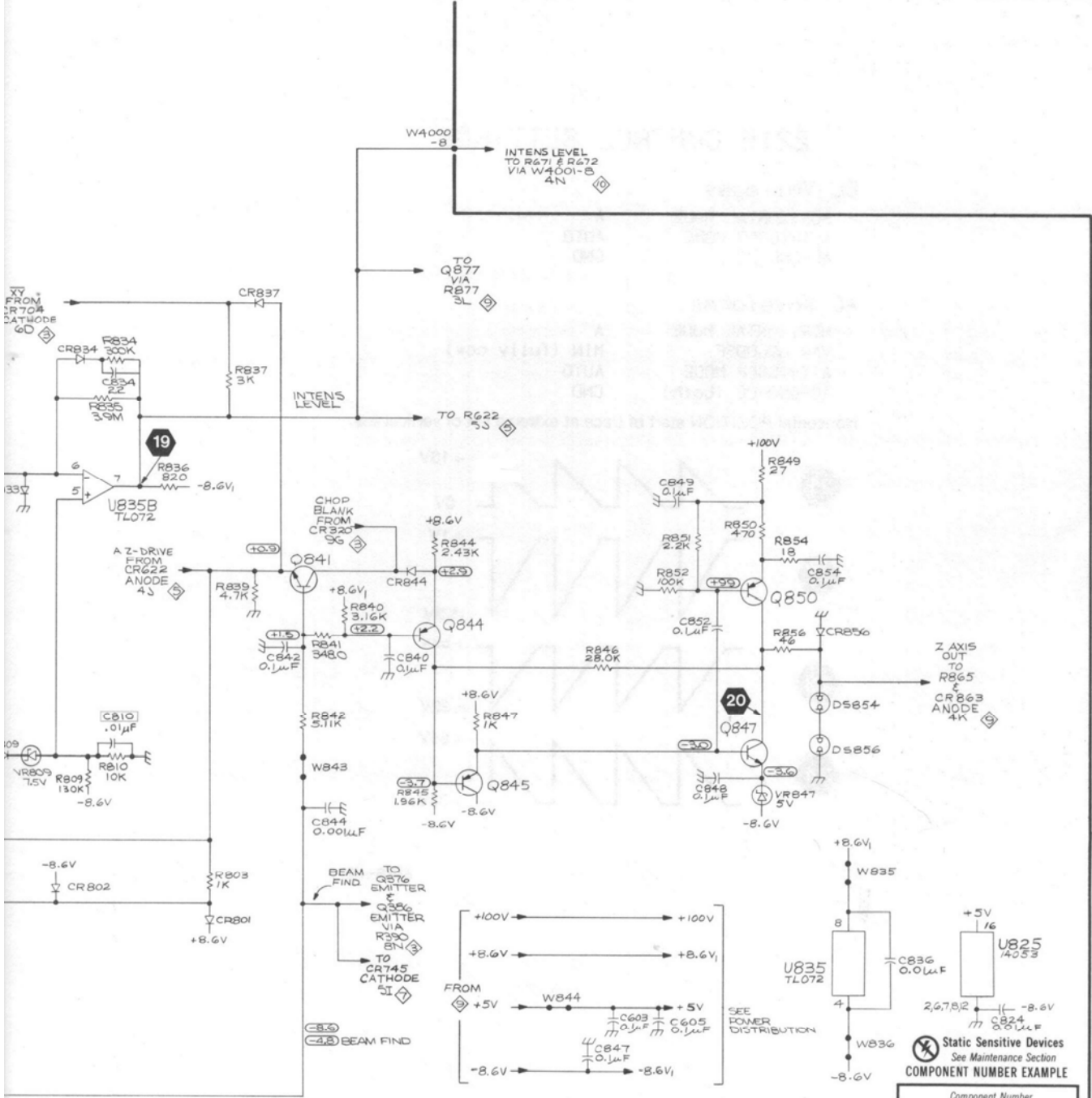

Static Sensitive Devices  
See Maintenance Section  
**COMPONENT NUMBER EXAMPLE**

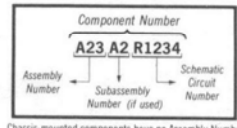

SEE PARTS LIST FOR EARLIER VALUES AND SERIAL NUMBER RANGES OF PARTS OUTLINED OR DEPICTED IN GREY.  
NUMERAL AND LETTER AT SIGNAL LINES TO OR FROM OTHER DIAGRAMS INDICATES THE GRID COORDINATE ON ANOTHER SCHEMATIC (FOR EXAMPLE: 4E)

Chassis-mounted components have no Assembly Number prefix—see end of Replaceable Electrical Parts List.

AIO PARTIAL MAIN BOARD

3826-36  
REV OCT 1981

AUTO INTENSITY & Z-AXIS

## 2215 CONTROL SETTINGS

### DC Voltages

HORIZONTAL MODE	A
A TRIGGER MODE	AUTO
AC-GND-DC	GND

### AC Waveforms

HORIZONTAL MODE	A
VAR HOLDOFF	MIN (fully ccw)
A TRIGGER MODE	AUTO
AC-GND-DC (both)	GND

Horizontal POSITION start of trace at extreme left of vertical line.

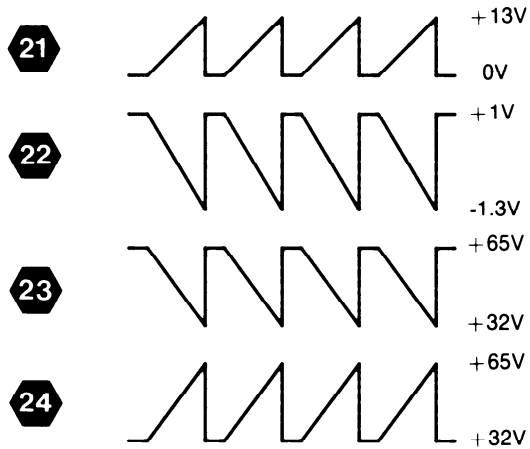

3826-13

XY AMPLIFIER / HORIZ OUTPUT



ASSEMBLY A10											
CIRCUIT NUMBER	SCHEM LOCATION	BOARD LOCATION	CIRCUIT NUMBER	SCHEM LOCATION	BOARD LOCATION	CIRCUIT NUMBER	SCHEM LOCATION	BOARD LOCATION	CIRCUIT NUMBER	SCHEM LOCATION	BOARD LOCATION
C702	7D	7D	CR783	2L	3H	R708	7D	6E	R781	2N	3G
C708	7D	6E				R709	7E	6E	R782	3L	2G
C745	5I	2I	P7001-4	9H	6F	R711	8F	6E	R785	2M	3G
C748	5I	2I	P7001-5	3I	6F	R712	6E	6E	R786	1N	3G
C754	5J	4I	P7001-6	6F	6F	R745	5J	2H	R787	1N	2G
C770	5M	3G	P6001-9	3D	8F	R746	5J	2H	R788	2N	2G
C773	8M	3G	P6001-10	4D	8F	R748	5I	2I	R789	1N	3F
C774	8M	3G				R749	5I	2I	R792	4N	3G
C777	7N	3F	Q703	8D	5E	R751	5J	3I	R793	4N	3G
C779	7N	3G	Q706	8D	5E	R752	5K	4H	R796	9J	3I
C781	2M	2G	Q708	7F	6E	R753	7K	3H	R797	9J	3I
C783	2M	3G	Q714	7F	6F	R754	4K	3I	R798	8J	2G
C784	2M	3G	Q747	5J	3H	R756	7J	3I	R799	8J	4F
C787	1N	2G	Q753	7K	3H	R757	7J	3I			
C789	1N	2G	Q763	3K	4H	R758	7J	4H	VR781	2M	2G
C796	9J	3I	Q765	5L	3G	R760	3J	4G			
C797	9K	3I	Q770	7L	3G	R761	4J	3I	W399	8J	3I
C798	8J	2H	Q775	8N	3F	R762	4K	3H	W696	4C	8G
C799	8J	4G	Q779	7N	3F	R763	2K	3H	W763	3J	5F
C841	9J	6F	Q780	2M	2G	R765	4L	3H	W764	3J	4F
C845	9J	3J	Q785	2N	2F	R766	5L	4G	W840	9I	9F
			Q789	1N	3G	R768	5M	2G	W841	9I	7F
CR745	5I	2I				R771	8N	3F	W842	9I	7F
CR748	5I	2I	R701	8B	5D	R772	7L	3H	W845	9J	3J
CR749	5I	2I	R702	7C	6E	R775	8M	3G	W846	9J	3I
CR770	5M	3H	R703	8C	6E	R776	7N	3F	W847	9J	3I
CR772	5K	3H	R704	6B	6F	R777	7N	3F	W967	8J	5F
CR773	7L	3H	R705	8D	5E	R778	8N	3F	W969	8I	4J
CR780	5M	3G	R706	8E	6E	R779	7N	3F	W4000-5	3C	7F
CR782	5L	3H	R707	8E	6E	R780	2M	2G	W4000-11	4C	7F

Partial A10 also shown on diagrams 2, 3, 4, 5, 6, 9 and 10.

ASSEMBLY A11											
CIRCUIT NUMBER	SCHEM LOCATION	BOARD LOCATION	CIRCUIT NUMBER	SCHEM LOCATION	BOARD LOCATION	CIRCUIT NUMBER	SCHEM LOCATION	BOARD LOCATION	CIRCUIT NUMBER	SCHEM LOCATION	BOARD LOCATION
C725†	2D	1E	J2000-9	2D	3D	R726	2C	1E			
C726	2C	1E									

Partial A11 also shown on diagrams 1, 2, 3, 4, 5, 6, 8, 9 and 10.

ASSEMBLY A12											
CIRCUIT NUMBER	SCHEM LOCATION	BOARD LOCATION	CIRCUIT NUMBER	SCHEM LOCATION	BOARD LOCATION	CIRCUIT NUMBER	SCHEM LOCATION	BOARD LOCATION	CIRCUIT NUMBER	SCHEM LOCATION	BOARD LOCATION
C720	4G	2D	Q684	3E	2F	R685	3E	3F	R733	2G	1E
C732	1G	1D	Q720	5G	1D	R720	5G	1D	R734	2H	1E
C734	2H	2E	Q730	2F	1E	R721	3G	1E	R736	3H	2E
C736	3G	2E	Q731	2G	1D	R722	5F	2D	R737	3H	2E
			Q736	3G	1E	R723	5F	2D	R739	3H	1D
P2000-9	2D	4D				R724	2G	1E			
P6000-9	3D	3F	R633	4E	1F	R725	2E	2D	S734	1H	1D
P6000-10	4D	3F	R634	4F	1E	R728	2F	2E			
P7000-5	3I	1D	R635	4E	3F	R729	2E	1E	W734	2E	1E
P7000-6	5G	1D	R682	3E	1F	R730	3G	2E			
			R683	3E	1F	R731	3G	2E			
Q634	4E	2F	R684	3E	1E	R732	2F	1E			

Partial A12 also shown on diagrams 1, 5, 8 and 10.

†Located on back of board.

A B C D E F G H

← WAVEFORMS

1  
2  
3  
4  
5  
6  
7  
8  
9

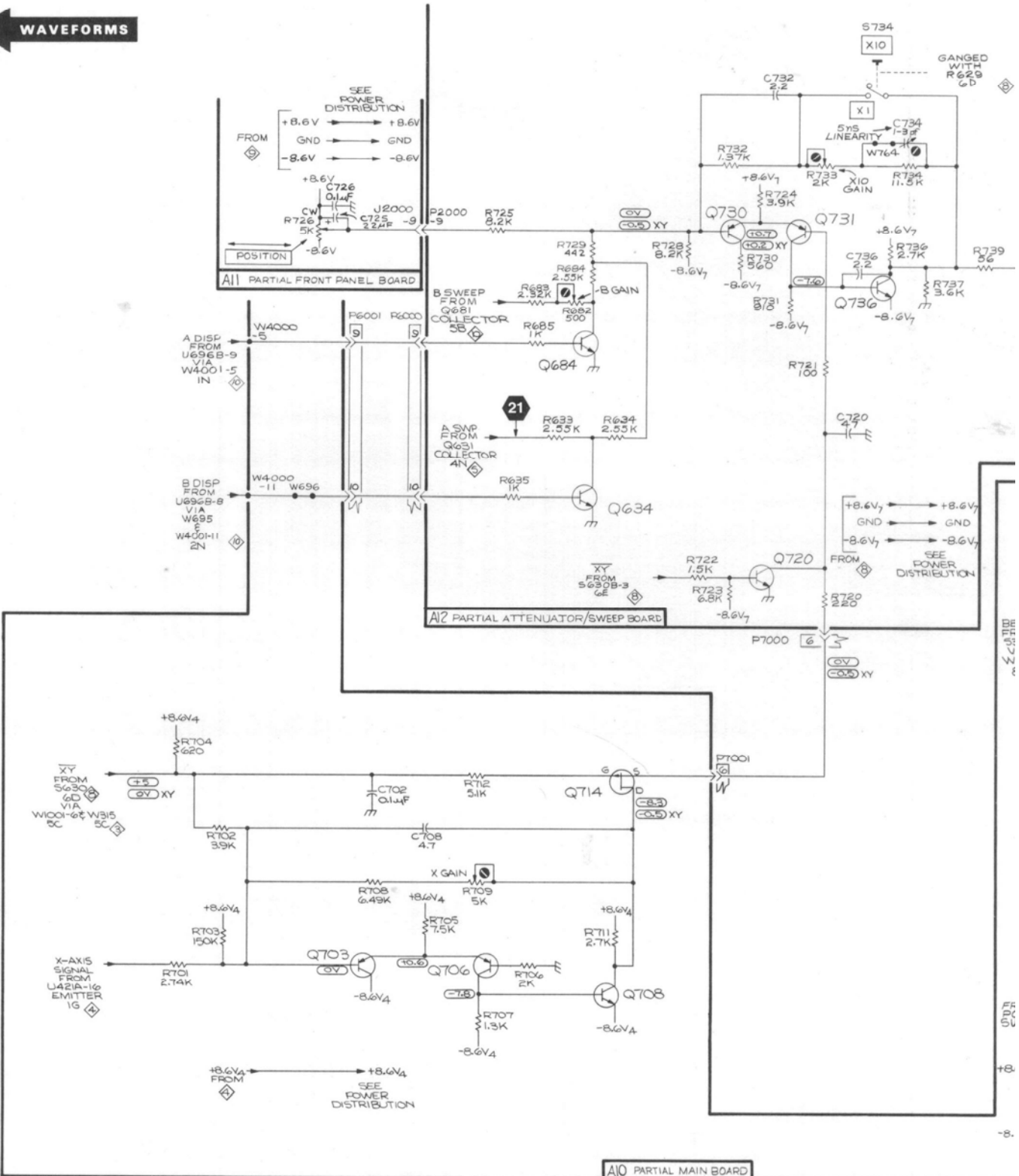

2215

3826-37  
REV OCT 1981

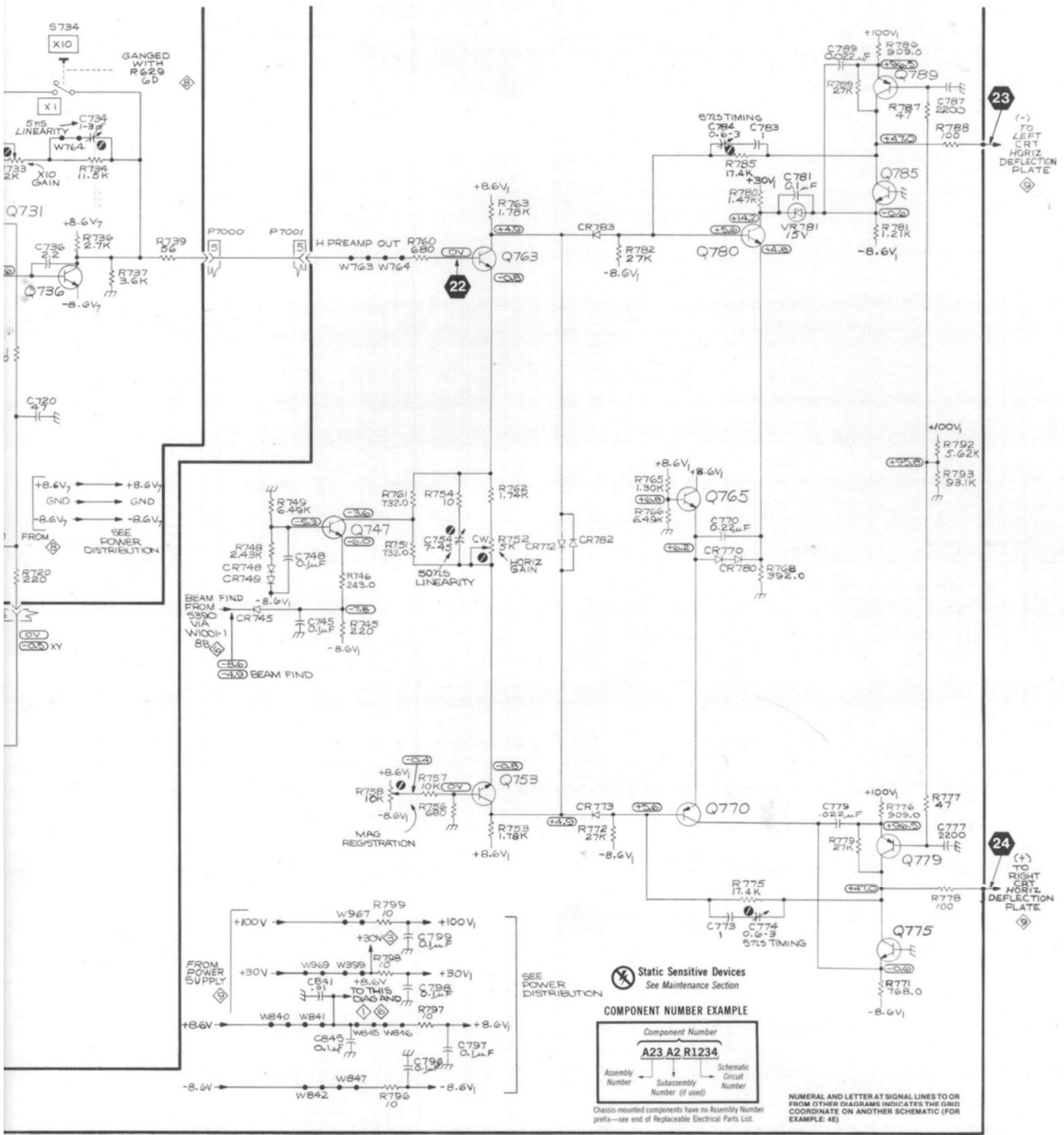

## TIMING SWITCH



<b>ASSEMBLY A11</b>					
CIRCUIT NUMBER	SCHEM LOCATION	BOARD LOCATION	CIRCUIT NUMBER	SCHEM LOCATION	BOARD LOCATION
J2000-7	1M	3D	J2000-8	1M	3D
<i>Partial A11 also shown on diagrams 1, 2, 3, 4, 5, 6, 7, 9 and 10.</i>					
<b>ASSEMBLY A12</b>					
CIRCUIT NUMBER	SCHEM LOCATION	BOARD LOCATION	CIRCUIT NUMBER	SCHEM LOCATION	BOARD LOCATION
C625	3L	4E	R625	4F	4E
C626	3L	4E	R626	3E	4E
C628A	2K	4D	R627	7C	1E
C628B	2L	5E	R628	2L	4E
C628C	9I	2E	R629	6C	1E
C628D	9J	2E	R636	6L	2E
C636	6L	2E	R676	8E	2E
C675	8J	3E	R677	7L	2E
C676	8J	3E	R678	9I	2E
C677	7L	3F	R679	8L	2E
C679	8L	3F	R686	5C	1F
C738	8L	2E	R691	6C	1E
C741	7L	2E	R738	8M	2D
			R741	7M	1E
P2000-7	1M	4D			
P2000-8	1M	4D	S630A	2K	3D
P7000-1	6M	1D	S630B	2G	3D
P7000-2	7M	1D	S630C	9G	3D
P7000-3	8M	1D	S630	6E	3D
P7000-4	7M	1D			
P7000-7	1M	1D	VR629	6C	1F
O629	6C	1F			
<i>Partial A12 also shown on diagrams 1, 5, 7 and 10.</i>					



A B C D E F G H

1  
2  
3  
4  
5  
6  
7  
8  
9

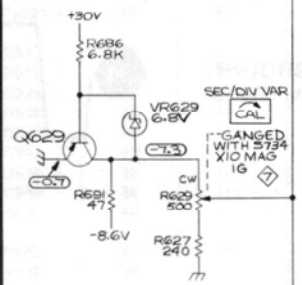
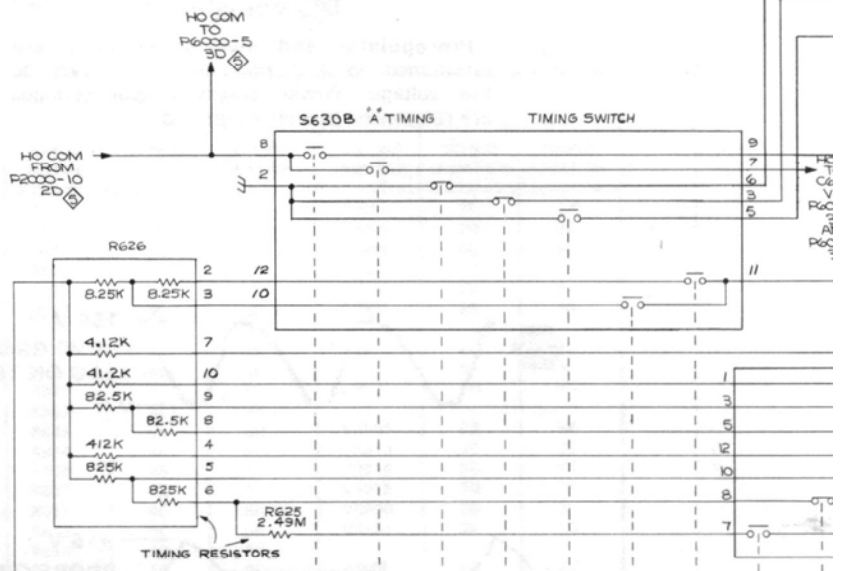

S630  
A AND B SEC/DIV  
(SHOWN IN XY POSITION)  
DOT INDICATES SWITCH CLOSED

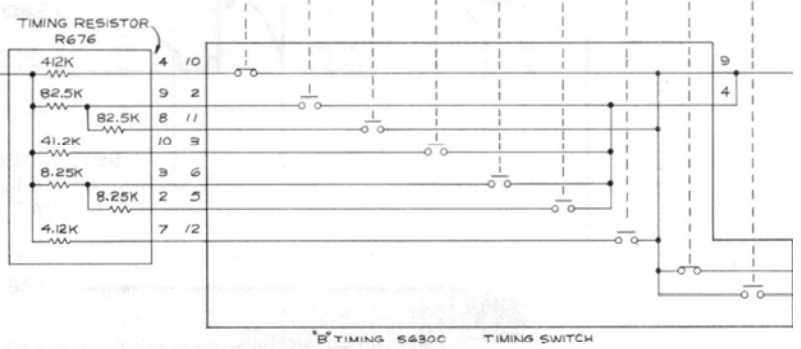
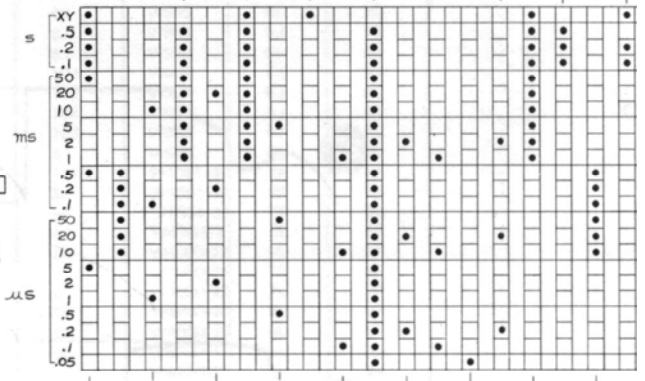

H I J K L M N

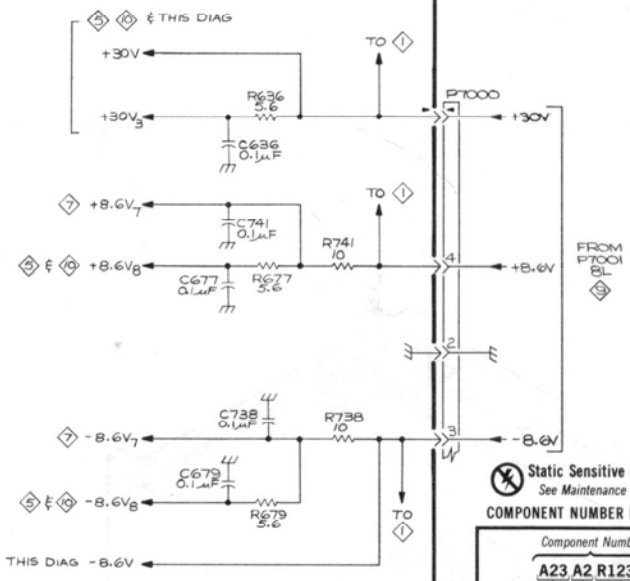
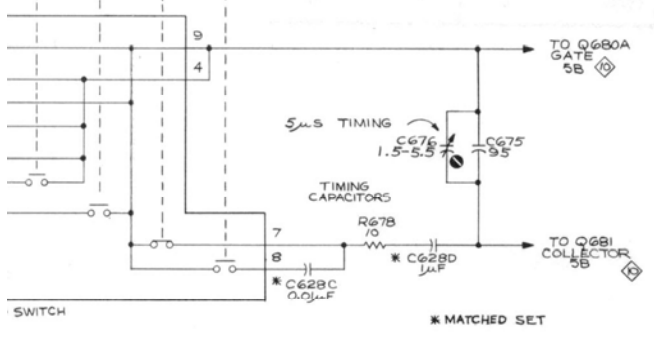
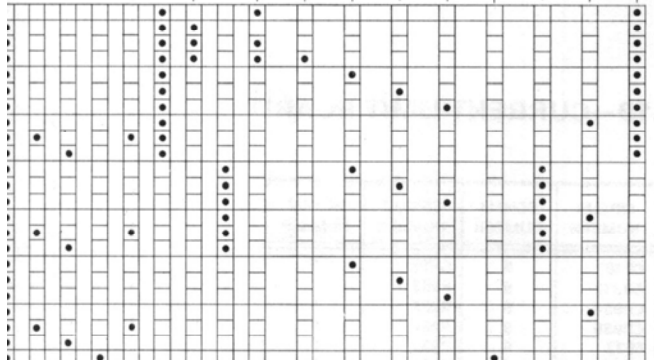
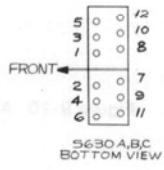
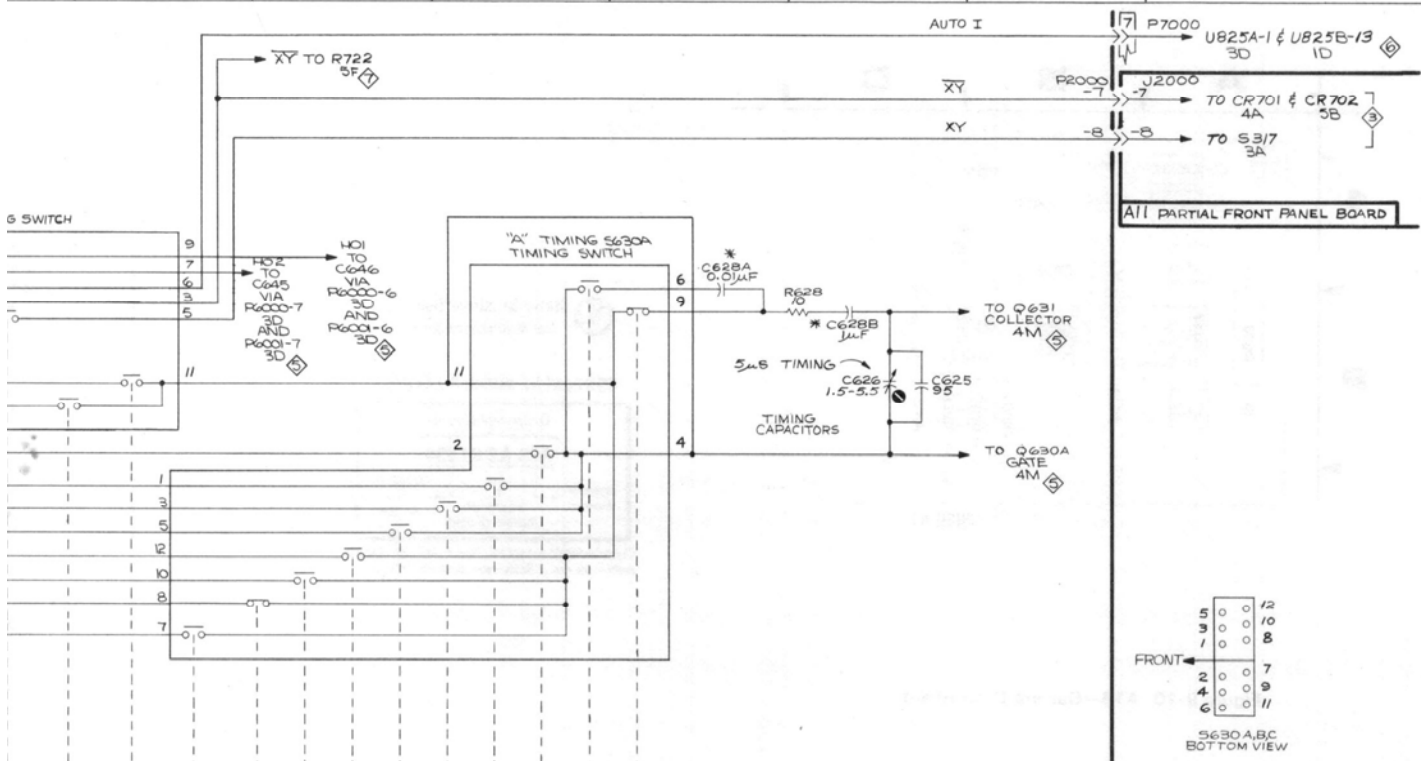

Static Sensitive Devices  
See Maintenance Section

COMPONENT NUMBER EXAMPLE

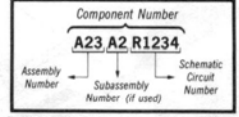

Chassis-mounted components have no Assembly Number prefix—see end of Replaceable Electrical Parts List.

NUMERAL AND LETTER AT SIGNAL LINES TO OR FROM OTHER DIAGRAMS INDICATES THE GRID COORDINATE ON ANOTHER SCHEMATIC (FOR EXAMPLE: 4E)

A12 PARTIAL ATTENUATOR/SWEEP BOARD

TIMING SWITCH 8

ASSEMBLY A11					
CIRCUIT NUMBER	SCHEM LOCATION	BOARD LOCATION	CIRCUIT NUMBER	SCHEM LOCATION	BOARD LOCATION
J2000-7	1M	3D	J2000-8	1M	3D
<i>Partial A11 also shown on diagrams 1, 2, 3, 4, 5, 6, 7, 9 and 10.</i>					
ASSEMBLY A12					
CIRCUIT NUMBER	SCHEM LOCATION	BOARD LOCATION	CIRCUIT NUMBER	SCHEM LOCATION	BOARD LOCATION
C625	3L	4E	R625	4F	4E
C626	3L	4E	R626	3E	4E
C628A	2K	4D	R627	7C	1E
C628B	2L	5E	R628	2L	4E
C628C	9I	2E	R629	6C	1E
C628D	9J	2E	R636	6L	2E
C636	6L	2E	R676	8E	2E
C675	8J	3E	R677	7L	2E
C676	8J	3E	R678	9I	2E
C677	7L	3F	R679	8L	2E
C679	8L	3F	R686	5C	1F
C738	8L	2E	R691	6C	1E
C741	7L	2E	R738	8M	2D
P2000-7	1M	4D	R741	7M	1E
P2000-8	1M	4D	S630A	2K	3D
P7000-1	6M	1D	S630B	2G	3D
P7000-2	7M	1D	S630C	9G	3D
P7000-3	8M	1D	S630	6E	3D
P7000-4	7M	1D	VR629	6C	1F
P7000-7	1M	1D			
Q629	6C	1F			

*Partial A12 also shown on diagrams 1, 5, 7 and 10.*



**TIMING SWITCH**

8 TIMING SWITCH

NUMERAL AND LETTERS AT SIGNAL LINES TO ORIGINATE ON OTHER DIAGS INCHARTS THE GRID FROM OTHER DIAGS INCHARTS THE GRID

cross-mounted components have no Assembly Number prefix—see end of Replaceable Electrical Parts List



Static Sensitive Devices See Maintenance Section

A12 PARTIAL ATTENUATOR/SWEEP BOARD

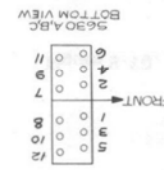
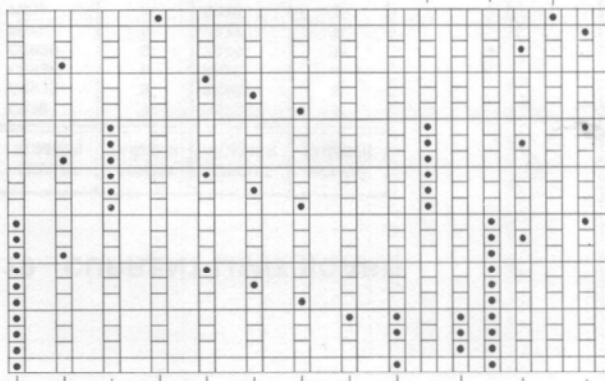
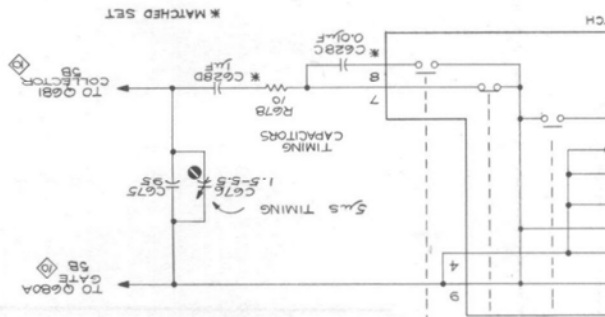
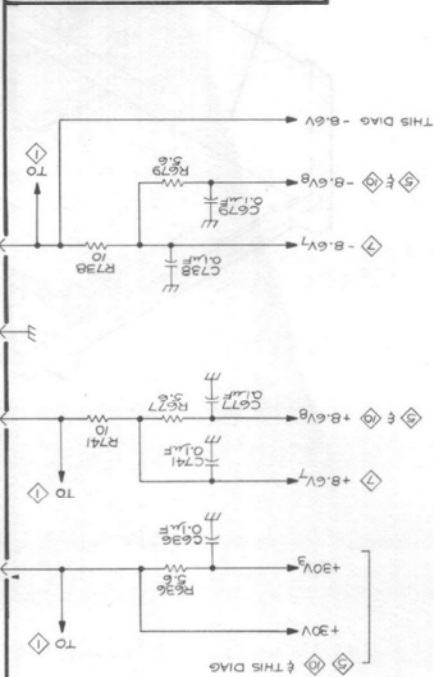

All PARTIAL FRONT PANEL BOARD

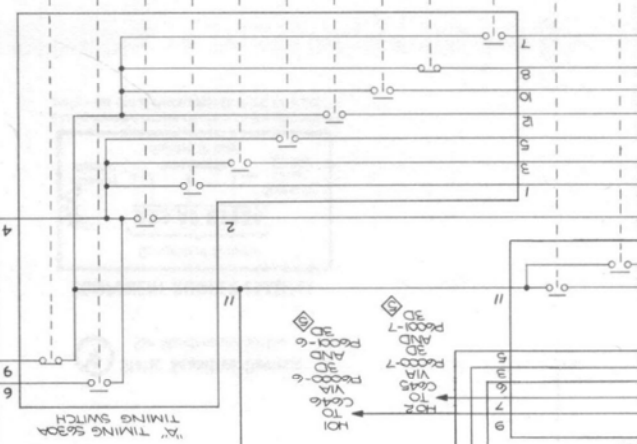
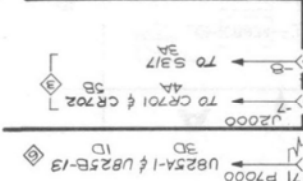

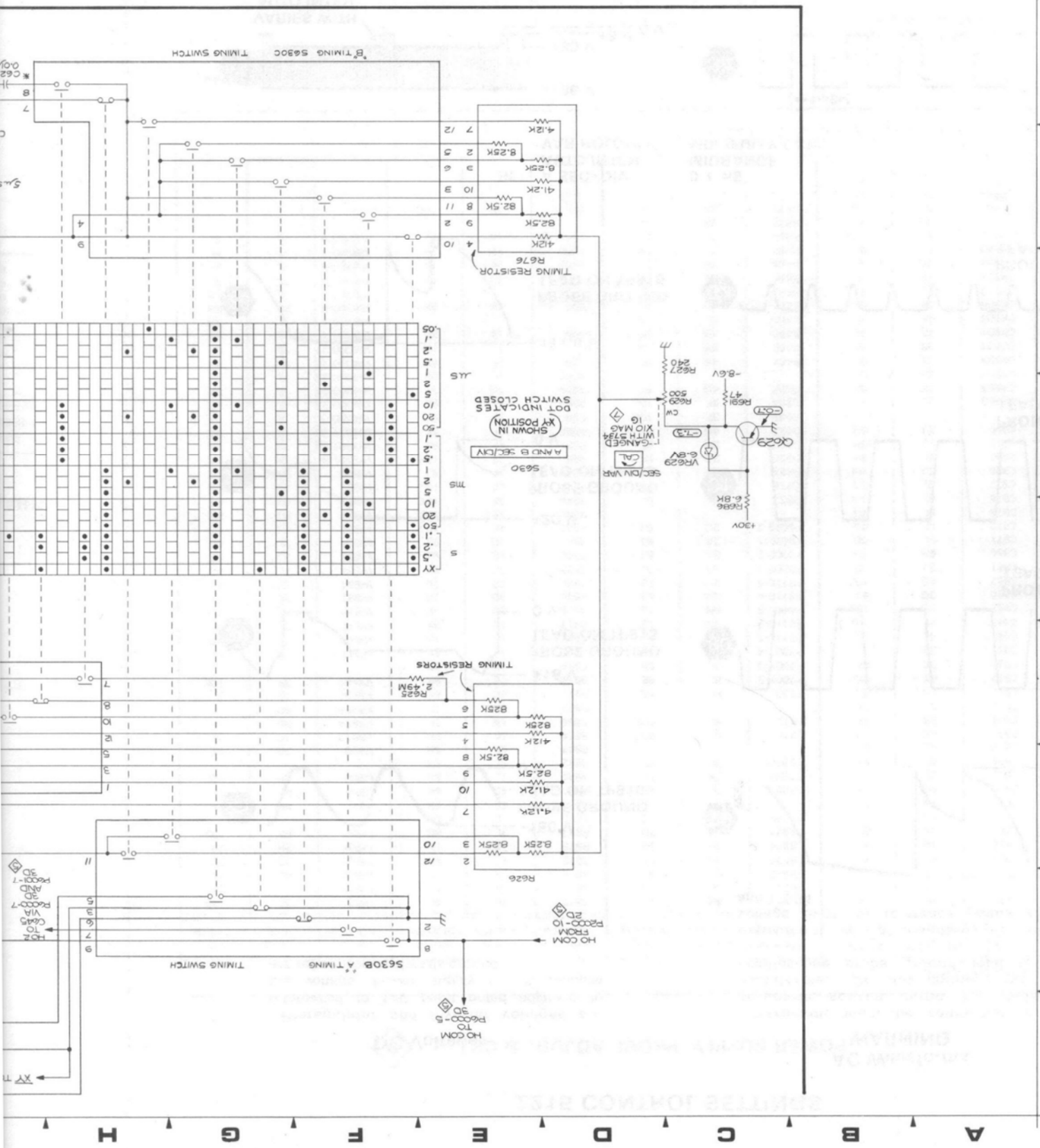

9  
8  
7  
6  
5  
4  
3  
2  
1

A  
B  
C  
D  
E  
F  
G  
H

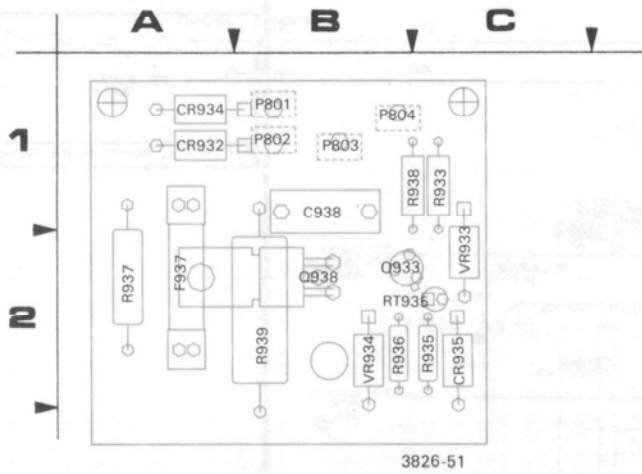

 **Static Sensitive Devices**  
See Maintenance Section

**COMPONENT NUMBER EXAMPLE**

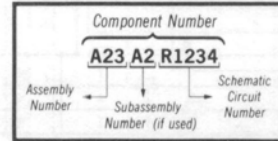

Chassis-mounted components have no Assembly Number prefix—see end of Replaceable Electrical Parts List.

Figure 9-10. A19—Current Limit board.

**A19—CURRENT LIMIT BOARD**

CIRCUIT NUMBER	SCHEM NUMBER	CIRCUIT NUMBER	SCHEM NUMBER
C938	9	Q938	9
CR932	9	R933	9
CR934	9	R935	9
CR935	9	R936	9
F937	9	R937	9
P801	9	R938	9
P802	9	R939	9
P803	9	RT935	9
P804	9	VR933	9
Q933	9	VR934	9

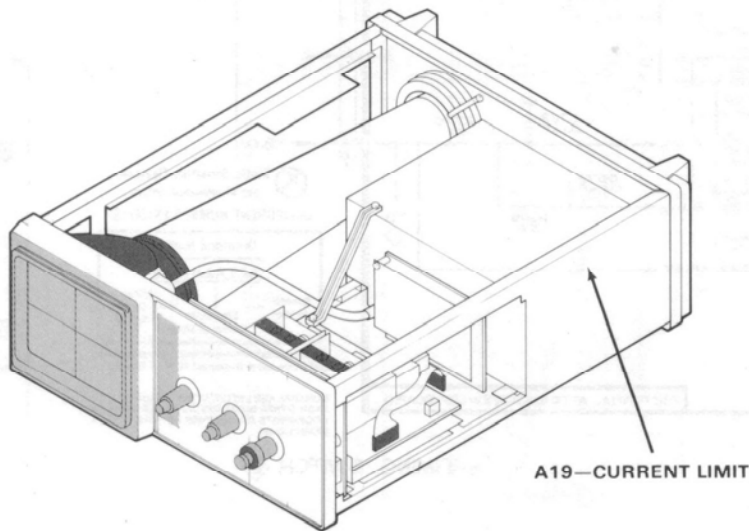

# 2215 CONTROL SETTINGS

## DC Voltages

Preregulator and inverter voltages are referenced to test point noted adjacent to the voltage. Power supply output voltages are referenced to chassis ground.

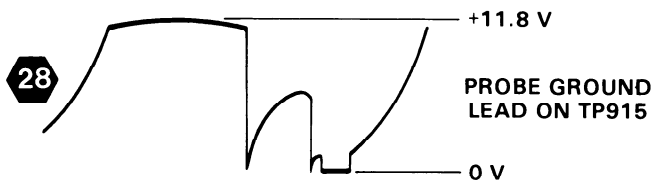
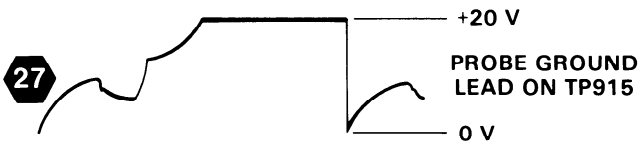
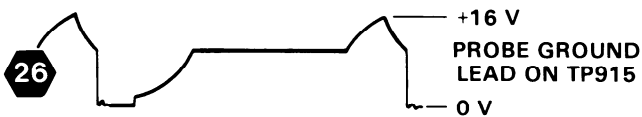

## AC Waveforms WARNING

Instrument must be connected to the ac-power source using 1:1 isolation transformer. Do not connect the test oscilloscope probe ground lead to the inverter circuit test points if the instrument is not isolated. AC-source voltage exist on reference points TP915 and TP934.

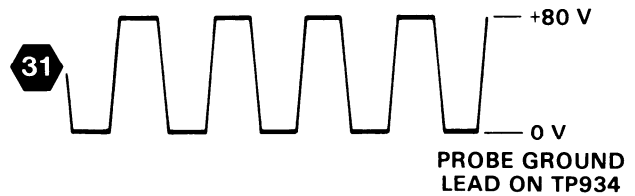
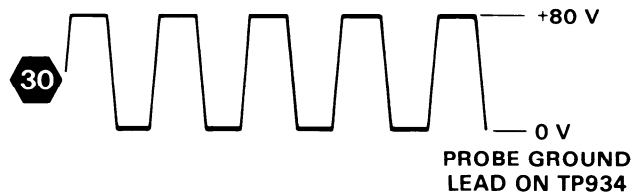
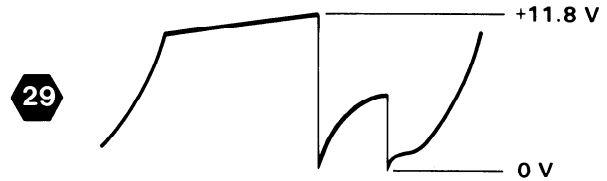

SET: A SEC/DIV  
AUTO INTEN  
VAR HOLDOFF

0.1 mS  
MIDRANGE  
MIN (FULLY CCW)

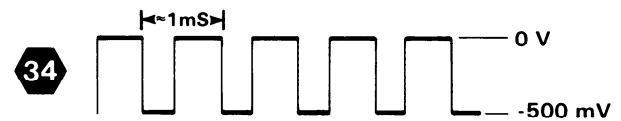
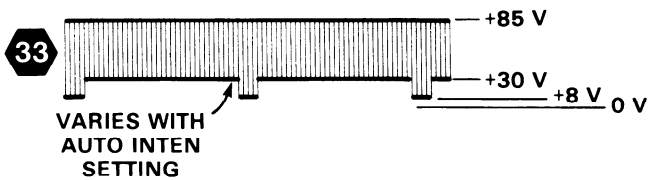

3826-19

REV OCT 1981

POWER SUPPLY, PROBE ADJUST & CRT



ASSEMBLY A10											
CIRCUIT NUMBER	SCHEM LOCATION	BOARD LOCATION	CIRCUIT NUMBER	SCHEM LOCATION	BOARD LOCATION	CIRCUIT NUMBER	SCHEM LOCATION	BOARD LOCATION	CIRCUIT NUMBER	SCHEM LOCATION	BOARD LOCATION
C447	4B	5K	CR967	4H	7G	R872	3L	4I	TP501	7F	10B
C448	6B	5F	CR971	5H	8G	R873	3N	1I	TP915	3D	8K
C861	4J	7I	CR972	5H	9H	R874	3N	1I	TP920	4C	8K
C863	4J	7I	CR973	6H	9G	R875	4L	4H	TP921	3D	8J
C864	3K	6I	CR974	6H	9G	R876	5N	1I	TP934	2H	8J
C865	3K	6I	CR977	2K	7H	R877	3L	6G	TP952	5F	10J
C871	2N	1J	CR985	5J	9G	R878	3L	5H			
C873	3N	1J				R879	4L	5H	U931	5E	9K
C876	5N	1J	DS867	2J	5I	R880	4L	5H	U985	6J	9I
C877	2L	1J	DS868	2K	5I	R881	4L	5H	U990	2H	6G
C878	4L	5H	DS870	7K	5I	R882	5L	5H			
C879	4L	5H				R883	5L	5H	VR901	3B	5K
C886	4N	1J	L971	5I	8G	R884	5K	5H	VR913	3C	8K
C901	2B	5K	L972	6I	10H	R886	4N	1I	VR914	5D	8K
C912	6C	9K				R887	4N	1I	VR915	6D	8K
C915	6D	9K	P7001-1	8L	6E	R911	4C	8K	VR938	3E	8I
C917	4E	9K	P7001-2	8L	6E	R912	6C	9K	VR951	3F	10K
C926	3C	6K	P7001-3	8L	6E	R914	4D	8K			
C937	3E	7J	P7001-4	8L	6F	R915	5C	8K	W447	5B	5J
C945	4E	10J	P8710-1	4N	1J	R916	4E	9K	W448	5B	6G
C947	4F	10J	P8710-2	3N	1J	R917	4E	8K	W877	3L	4I
C951	3G	10J	P8710-3	5N	1J	R918	5D	9K	W878	3L	4I
C956	3G	9J	P8710-4	2N	1J	R920	3D	7K	W887	2L	4J
C957	4G	10J	P8710-5	2L	1J	R925	2D	7K	W964	3J	4J
C961	3J	6G	P9000-1	2A	6J	R926	3C	6K	W965	4I	9G
C965	3H	7H	P9000-2	3A	6J	R940	4G	9J	W966	3J	7G
C971	5I	9G	P9025-1	2B	6J	R941	4G	9J	W968	3I	6G
C972	6I	9G	P9025-2	2C	6J	R942	4G	10J	W975	5J	9G
C975	5I	8G				R945	3F	10J	W976	6J	9G
C976	6I	10G	Q877	3L	5I	R946	3F	10K	W982	6J	4J
C977	2L	7H	Q918	4D	9K	R947	4F	10J	W985	6J	9G
C985	6J	10I	Q921	3C	8K	R948	4F	9J	W986	6J	9G
C990	2I	6H	Q925	2C	8K	R950	3F	10K	W1001-5	7F	5A
C992	2J	6H	Q940	3G	9I	R951	4F	9J	W1001-14	7F	6A
C995	2J	6H	Q942	4G	9I	R952	5F	9K	W1001-32	7F	9A
			Q948	3F	10K	R953	5F	9J	W4000-3	6L	6F
CR860	3J	7I	Q954	3F	10K	R954	4F	9K	W4000-23	6L	9F
CR863	4K	6I	Q956	4G	9K	R956	3G	9J	W4000-24	7L	9F
CR867	2J	6I				R990	2I	6H	W4000-25	7L	9F
CR868	2K	6I	R447	4B	6K	R992	2I	6H	W4000-26	6L	9F
CR903	3B	6K	R448	5B	5K	R994	2J	6H	W4000-27	6L	9F
CR904	4B	6K	R450	4B	5K	R995	2J	6H	W8700-1	5L	5H
CR905	4B	6K	R860	3J	4K				W8700-2	7L	5H
CR906	4B	6K	R861	4J	4K	S901	2A	5K	W8700-3	8L	5H
CR917	6D	8K	R863	4J	7I				W8700-4	8L	5H
CR931	3D	6K	R864	3J	6I	T448	5B	5J	W8700-5	7L	5I
CR933	2D	6K	R865	3K	6I	T925	3C	7K	W8700-6	7L	5I
CR940	5G	9I	R867	2J	6H	T940	2H	7H	W8700-7	7L	5I
CR942	5G	10J	R868	2J	6I	T942	4H	8J	W8700-8	5L	5I
CR956	3G	9J	R870	2N	1I						
CR961	3I	7G	R871	2N	1I	TP500	7F	10G			
CR963	3I	7G									
CR965	3H	7G									

Partial A10 also shown on diagrams 2, 3, 4, 5, 6, 7 and 10.

\*See Parts List for serial number ranges.

TABLE (CONT)





POWER SUPPLY, PROBE ADJUST & CRT



(CONT)

ASSEMBLY A11											
CIRCUIT NUMBER	SCHEM LOCATION	BOARD LOCATION	CIRCUIT NUMBER	SCHEM LOCATION	BOARD LOCATION	CIRCUIT NUMBER	SCHEM LOCATION	BOARD LOCATION	CIRCUIT NUMBER	SCHEM LOCATION	BOARD LOCATION
C531	8C	1D	P1000-2	8E	1B	R532	7C	1D	U535	8C	1D
CR536	8D	1D	P8006-1	1N	2A	R536	8D	1D	W1000-5 W1000-14 W1000-32	7E	4A
CR538	8D	1D	P8006-2	1N	2A	R537	8D	1D		7E	4B
P1000-1	8E	1B	R530	8C	1D	R538	8D	1B		7E	4E
			R531	8C	1D	R891	1N	2A			
						R975	1N	2A			
<i>Partial A11 also shown on diagrams 1, 2, 3, 4, 5, 6, 7, 8 and 10.</i>											
ASSEMBLY A19											
CIRCUIT NUMBER	SCHEM LOCATION	BOARD LOCATION	CIRCUIT NUMBER	SCHEM LOCATION	BOARD LOCATION	CIRCUIT NUMBER	SCHEM LOCATION	BOARD LOCATION	CIRCUIT NUMBER	SCHEM LOCATION	BOARD LOCATION
C938	2G	1B	P801	2E	1B	R933	1F	1C	RT935	2F	2B
CR932	2E	1A	P802	2E	1B	R935	2F	2C	VR933 VR934	1F	2C
CR934	2E	1A	P803	2G	1B	R936	2F	2B		1E	2B
CR935	2F	2C	P804	1E	1B	R937	2F	2A			
F937	2G	2A	Q933	1F	2B	R938	1G	1B			
			Q938	1G	2B	R939	2G	2B			
CHASSIS MOUNTED PARTS											
CIRCUIT NUMBER	SCHEM LOCATION	BOARD LOCATION	CIRCUIT NUMBER	SCHEM LOCATION	BOARD LOCATION	CIRCUIT NUMBER	SCHEM LOCATION	BOARD LOCATION	CIRCUIT NUMBER	SCHEM LOCATION	BOARD LOCATION
F901	2A	CHASSIS	L925	1C	CHASSIS	P8007-4	5L	CHASSIS	P8007-12	2L	CHASSIS
J1000	8E	CHASSIS	P8007-1	6M	CHASSIS	P8007-5	4N	CHASSIS	P8007-14	6M	CHASSIS
J9001	2A	CHASSIS	P8007-2	6M	CHASSIS	P8007-7	3N	CHASSIS	V870	1M	CHASSIS
			P8007-3	5L	CHASSIS	P8007-8	5N	CHASSIS			
						P8007-10	2N	CHASSIS			

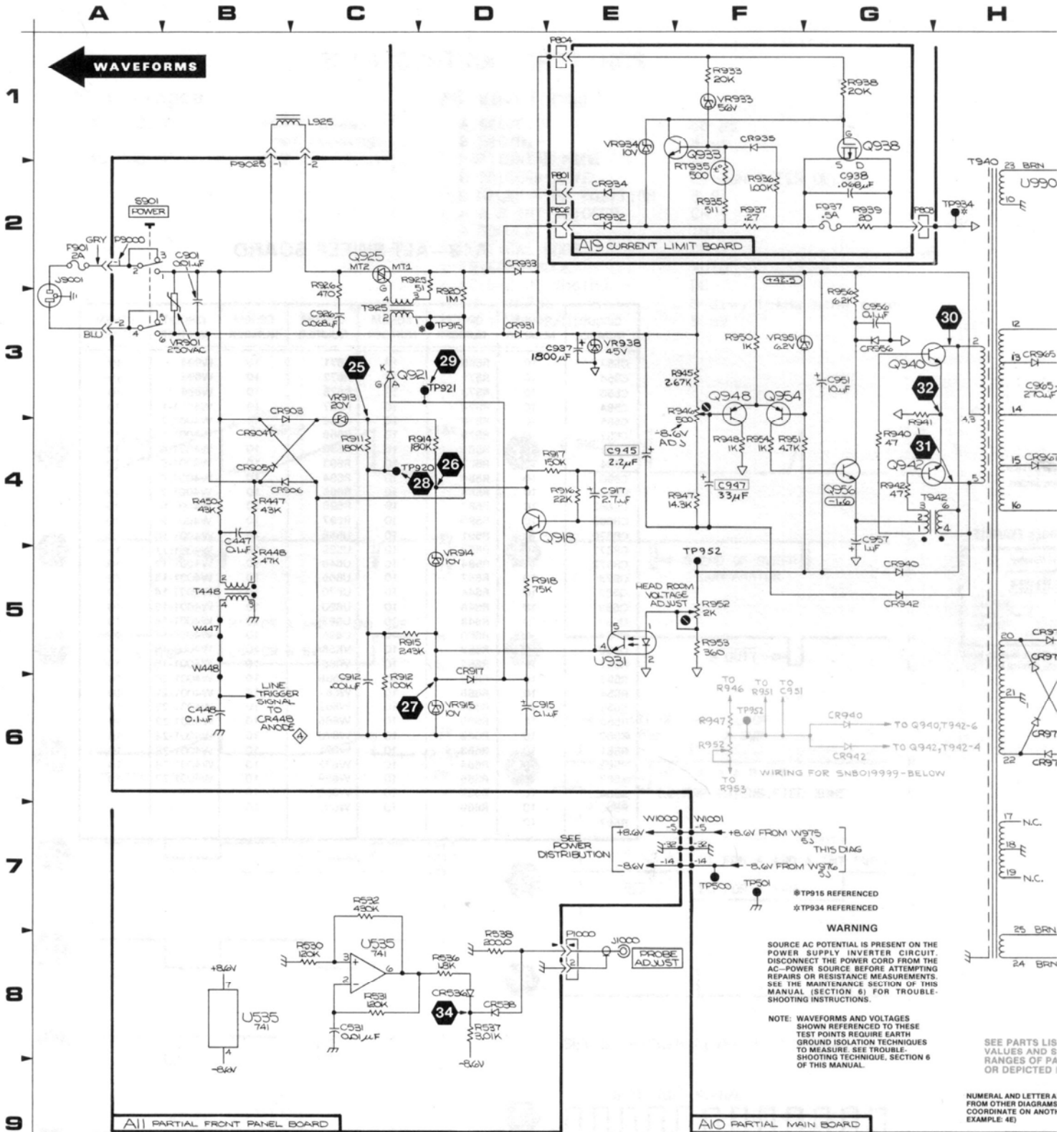

2215

3826-39  
REV OCT 1981



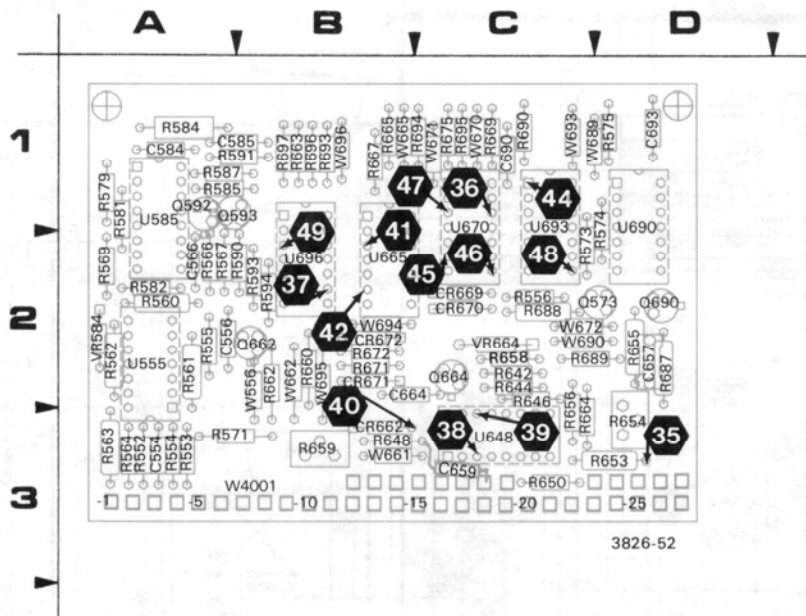
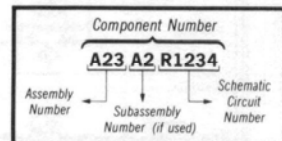

Figure 9-11. A13—Alt Sweep board.

 Static Sensitive Devices  
See Maintenance Section

**COMPONENT NUMBER EXAMPLE**



Chassis-mounted components have no Assembly Number prefix—see end of Replaceable Electrical Parts List.

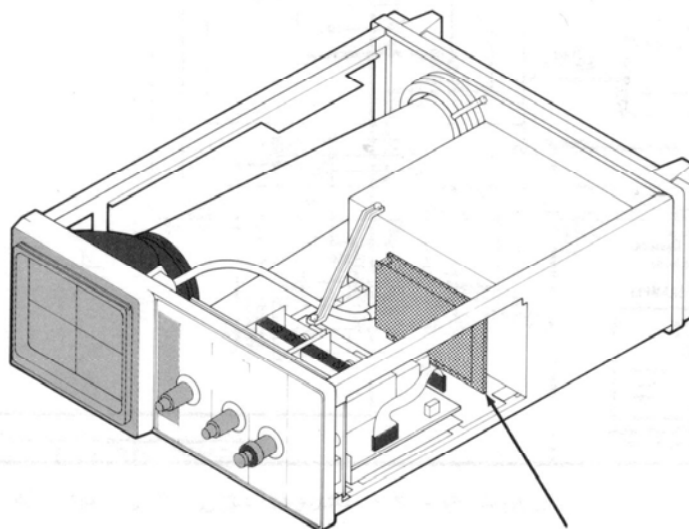

A13—ALT SWEEP

### A13—ALT SWEEP BOARD

CIRCUIT NUMBER	SCHEM NUMBER	CIRCUIT NUMBER	SCHEM NUMBER	CIRCUIT NUMBER	SCHEM NUMBER	CIRCUIT NUMBER	SCHEM NUMBER
C554	10	R569	10	R671	10	W694	10
C556	10	R571	10	R672	10	W695	10
C566	10	R573	10	R675	10	W696	10
C584	10	R574	10	R687	10	W4001-1	10
C585	10	R575	10	R688	10	W4001-2	10
C657	10	R579	10	R689	10	W4001-3	10
C659	10	R581	10	R690	10	W4001-4	10
C664	10	R582	10	R693	10	W4001-5	10
C690	10	R584	10	R694	10	W4001-6	10
C693	10	R585	10	R695	10	W4001-7	10
CR662	10	R587	10	R696	10	W4001-8	10
CR669	10	R590	10	R697	10	W4001-9	10
CR670	10	R591	10	U555	10	W4001-10	10
CR671	10	R593	10	U585	10	W4001-11	10
CR672	10	R594	10	U648	10	W4001-12	10
Q573	10	R642	10	U665	10	W4001-13	10
Q592	10	R644	10	U670	10	W4001-14	10
Q593	10	R646	10	U690	10	W4001-15	10
Q662	10	R648	10	U693	10	W4001-16	10
Q664	10	R650	10	U696	10	W4001-17	10
Q690	10	R653	10	VR584	10	W4001-18	10
R552	10	R654	10	VR664	10	W4001-19	10
R553	10	R655	10	W556	10	W4001-20	10
R554	10	R656	10	W661	10	W4001-21	10
R555	10	R659	10	W662	10	W4001-22	10
R556	10	R660	10	W665	10	W4001-23	10
R560	10	R662	10	W670	10	W4001-24	10
R561	10	R663	10	W671	10	W4001-25	10
R562	10	R664	10	W672	10	W4001-26	10
R563	10	R665	10	W689	10	W4001-27	10
R564	10	R667	10	W690	10		
R566	10	R669	10	W693	10		
R567	10						

REV OCT 1981

Tektronix 2215 Oscilloscope.max

## 2215 CONTROL SETTINGS

### DC Voltages

A TRIGGER	NORM (sweep not running)
AC-GND-DC (both)	GND

### AC Waveforms

A SEC/DIV	50 $\mu$ s
B SEC/DIV	5 $\mu$ s
HORIZONTAL MODE	ALT
B TRIGGER LEVEL	CW-RUN AFTER DELAY
B DELAY TIME POSITION	5.0
A & B INT TRIGGER	CH 1
A SOURCE	INT
VERTICAL MODE	CH 1
TRIGGER MODE	AUTO
AC-GND-DC (both)	DC
CH 1 INPUT	5-div, 1-kHz sine wave
CH 1 VOLTS/DIV	5 mV

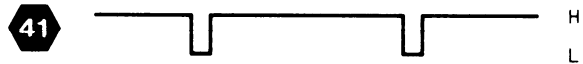
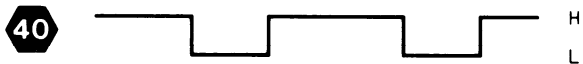
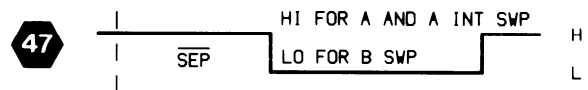
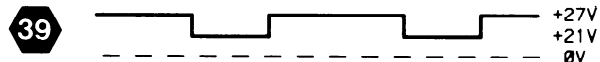
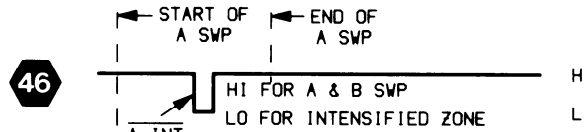
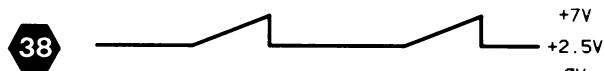
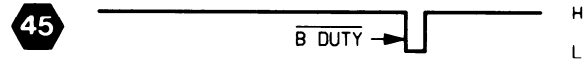
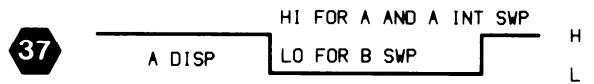
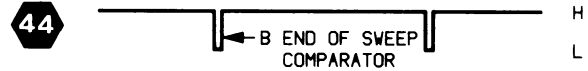
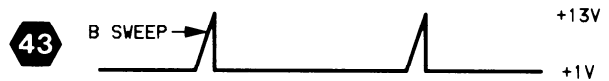
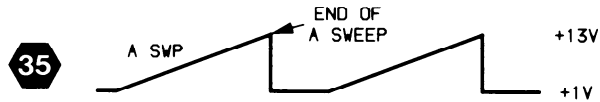

SET B TRIGGER LEVEL TO MIDRANGE

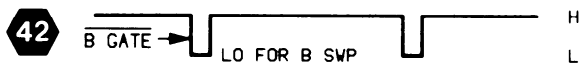

ALTERNATE B SWEEP



ASSEMBLY A10											
CIRCUIT NUMBER	SCHEM LOCATION	BOARD LOCATION	CIRCUIT NUMBER	SCHEM LOCATION	BOARD LOCATION	CIRCUIT NUMBER	SCHEM LOCATION	BOARD LOCATION	CIRCUIT NUMBER	SCHEM LOCATION	BOARD LOCATION
C564	8C	8A	P7055-2	4C	10F	W606	3D	7F	W4000-10	2D	7F
C569	9D	7A	P7055-3	3C	10F	W650	4D	10F	W4000-12	2D	8F
C601	2C	9B				W1001-17	1C	6A	W4000-13	1D	8F
C608	3C	8G				W1001-18	9C	7A	W4000-14	4D	8F
C648	1C	8G	R607	2C	7F	W1001-25	2C	8A	W4000-15	3D	8F
C651	1C	7A	R649	1C	10C	W1001-26	2C	8A	W4000-16	3D	8F
C658*	4D	10E	R651	3D	9F	W1001-27	2C	8A	W4000-17	6D	8F
			R673	6C	8F	W1001-28	2C	8A	W4000-19	1D	8F
P6001-2	6C	8F	R674	6D	8F	W1001-29	2C	8A	W4000-20	3D	8F
P6001-3	6C	8F				W1001-30	7C	8A	W4000-21	2D	9F
P6001-8	5C	8F	VR657	3D	9E	W4000-1	8D	6F	W4000-22	5D	9F
P7055-1	4C	10F				W4000-2	7D	6F			
			W564	8D	8G	W4000-4	9D	7F			
			W571	9D	8G	W4000-6	2D	7F			

*Partial A10 also shown on diagrams 2, 3, 4, 5, 6, 7 and 9.*

ASSEMBLY A11											
CIRCUIT NUMBER	SCHEM LOCATION	BOARD LOCATION	CIRCUIT NUMBER	SCHEM LOCATION	BOARD LOCATION	CIRCUIT NUMBER	SCHEM LOCATION	BOARD LOCATION	CIRCUIT NUMBER	SCHEM LOCATION	BOARD LOCATION
C650	2C	1E	S650	2A	2E	W1000-18	9C	4C	W1000-29	2C	4D
R557	9C	1F	W636	9C	1F	W1000-25	2C	4D	W1000-30	7C	4D
			W638	8C	1F	W1000-26	2C	4D			
S564	7C	1E	W1000-17	1C	4C	W1000-27	2C	4D			
						W1000-28	2C	4D			

*Partial A11 also shown on diagrams 1, 2, 3, 4, 5, 6, 7, 8 and 9.*

ASSEMBLY A12											
CIRCUIT NUMBER	SCHEM LOCATION	BOARD LOCATION	CIRCUIT NUMBER	SCHEM LOCATION	BOARD LOCATION	CIRCUIT NUMBER	SCHEM LOCATION	BOARD LOCATION	CIRCUIT NUMBER	SCHEM LOCATION	BOARD LOCATION
C680	5B	3F	P6000-2	6C	4F	Q680A	5B	3E	R680	5B	3F
			P6000-3	6C	3F	Q680B	6B	3E	R681	5B	2F
CR676	6B	3E	P6000-8	5C	3F	Q681	5B	3F			
CR680	6B	3F									

*Partial A12 also shown on diagrams 1, 5, 7 and 8.*

\*See Parts List for serial number ranges.

TABLE (CONT) 

ASSEMBLY A13											
CIRCUIT NUMBER	SCHEM LOCATION	BOARD LOCATION	CIRCUIT NUMBER	SCHEM LOCATION	BOARD LOCATION	CIRCUIT NUMBER	SCHEM LOCATION	BOARD LOCATION	CIRCUIT NUMBER	SCHEM LOCATION	BOARD LOCATION
C554	8G	3A	R579	7H	1A	U555A	7G	2A	W661	4E	3B
C556	9M	2A	R581	7H	1A	U555B	8G	2A	W662	3H	2B
C566	7F	2A	R582	7G	2A	U555C	7F	2A	W665	5L	1B
C584	8M	1A	R584	8L	1A	U555D	7F	2A	W670	4L	1C
C585	8L	1B	R585	7H	1A	U555E	8F	2A	W671	2L	1C
C657	5H	2D	R587	6I	1A	U555F	7G	2A	W672	4L	2C
C659*	4E	3C	R590	6H	2B	U585A	7H	1A	W689	7J	1C
C664	3H	2B	R591	6I	1A	U585B	7H	1A	W690	2I	2C
C690	2J	1C	R593	6I	2B	U585C	6F	1A	W693	5L	1C
C693	8L	1D	R594	4I	2B	U585D	7I	1A	W694	3M	2B
			R642	4E	2C	U648A	3E	3C	W695	2M	2B
CR662	3H	3B	R644	4E	2C	U648B	4F	3C	W696	4L	1B
CR669	3M	2C	R646	4F	2C	U648C	4F	3C	W4001-1	8D	3A
CR670	4M	2C	R648	4E	3B	U648D	3F	3C	W4001-2	7D	3A
CR671	4N	2B	R650	3E	3C	U648E	3G	3C	W4001-3	8L	3A
CR672	3N	2B	R653	3F	3D	U665A	4I	2B	W4001-4	9D	3A
			R654	4F	3D	U665B	4K	2B	W4001-5	1N	3A
Q573	9H	2D	R655	4F	2D	U665C	4J	2B	W4001-6	2D	3A
Q592	6I	1A	R656	3F	3C	U665D	3I	2B	W4001-7	3N	3B
Q593	6I	1B	R658	4G	2C	U670A	3L	1C	W4001-8	4N	3B
Q662	3H	2B	R659	4D	2C	U670B	4M	1C	W4001-9	3N	3B
Q664	4G	2C	R660	3G	2B	U670C	3M	1C	W4001-10	2D	3B
Q690	5H	2D	R661	3G	2C	U670D	1J	1C	W4001-11	2N	3B
			R662	3H	2B	U690A	9H	1D	W4001-12	2D	3B
R552	8G	3A	R663	1K	1B	U690B	8J	1D	W4001-13	1D	3B
R553	8G	3A	R664	3G	3C	U690C	4K	1D	W4001-14	4D	3B
R554	8G	3A	R665	3H	1B	U690D	2I	1D	W4001-15	3D	3C
R555	8F	2A	R667	4H	1B	U690E	2I	1D	W4001-16	3D	3C
R556	9L	2C	R669	3M	1C	U690F	2K	1D	W4001-17	6D	3C
R560	7F	2A	R671	4M	2B	U693A	3I	1C	W4001-18	5N	3C
R561	7F	2A	R672	4N	2B	U693B	3L	1C	W4001-19	1D	3C
R562	7E	2A	R675	4M	1C	U693C	1K	1C	W4001-20	3D	3C
R563	8F	3A	R687	5H	2D	U693D	2J	1C	W4001-21	2D	3C
R564	8E	3A	R688	5H	2C	U696A	4J	2B	W4001-22	5D	3C
R566	6F	2A	R689	5H	2C	U696B	1L	2B	W4001-23	7L	3D
R567	6G	2A	R690	5H	1C				W4001-24	9L	3D
R569	7G	2A	R693	2K	1B	VR584	8L	2A	W4001-25	9L	3D
R571	9G	3A	R694	3L	1C	VR664*	3G	2C	W4001-26	8L	3D
R573	9H	2C	R695	1I	1C	W556	9L	2B	W4001-27	8L	3D
R574	8H	1D	R696	2L	1B						
R575	9J	1D	R697	1L	1B						
CHASSIS MOUNTED PARTS											
CIRCUIT NUMBER	SCHEM LOCATION	BOARD LOCATION	CIRCUIT NUMBER	SCHEM LOCATION	BOARD LOCATION	CIRCUIT NUMBER	SCHEM LOCATION	BOARD LOCATION	CIRCUIT NUMBER	SCHEM LOCATION	BOARD LOCATION
R658	4C	CHASSIS									

\*See Parts List for serial number ranges.



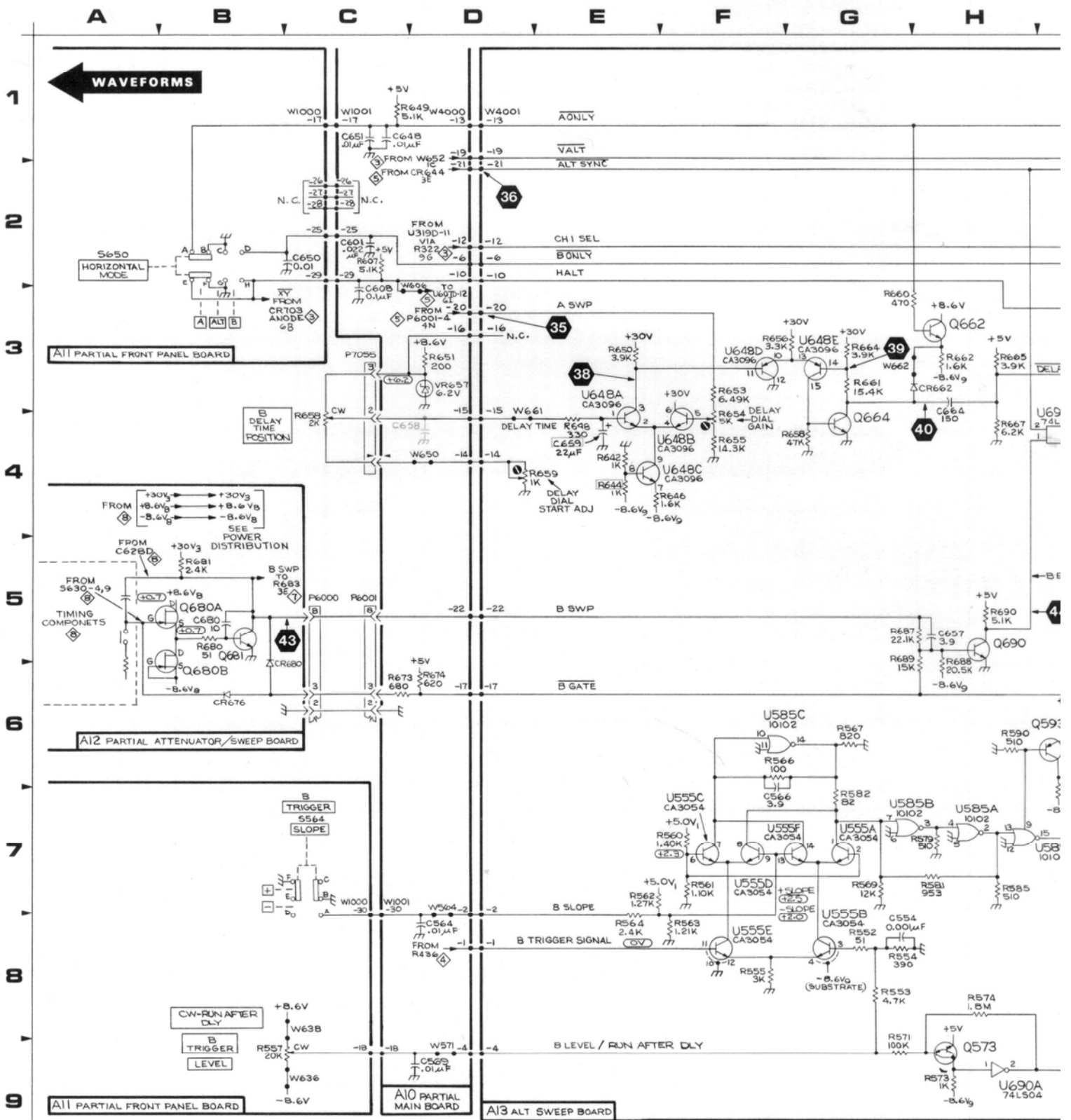

3826-40  
REV OCT 1981

H I J K L M N

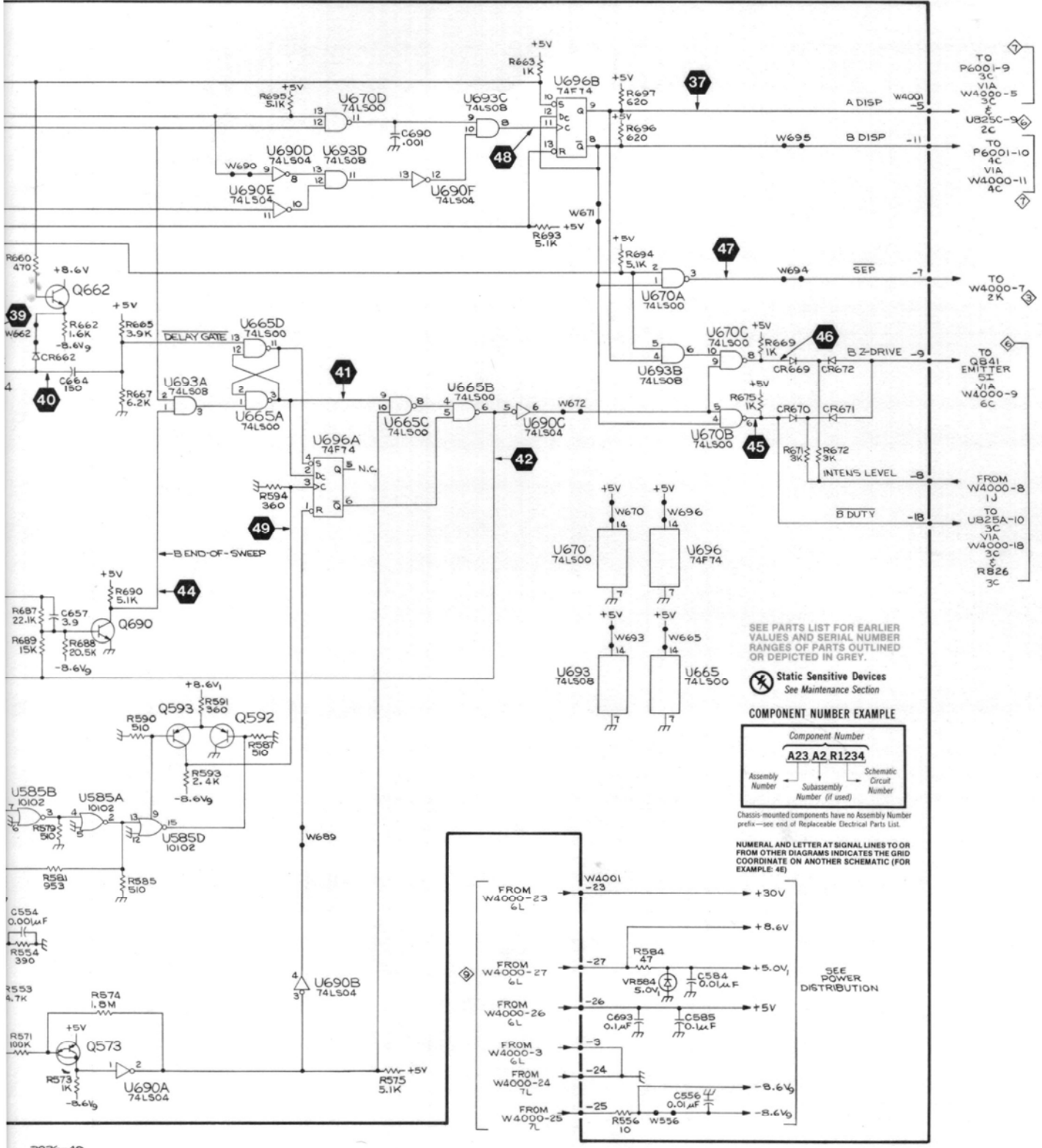

SEE PARTS LIST FOR EARLIER VALUES AND SERIAL NUMBER RANGES OF PARTS OUTLINED OR DEPICTED IN GREY.

Static Sensitive Devices See Maintenance Section

COMPONENT NUMBER EXAMPLE

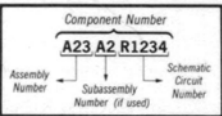

Chassis-mounted components have no Assembly Number prefix—see end of Replaceable Electrical Parts List.

NUMERAL AND LETTER AT SIGNAL LINES TO OR FROM OTHER DIAGRAMS INDICATES THE GRID COORDINATE ON ANOTHER SCHEMATIC (FOR EXAMPLE: 4E)

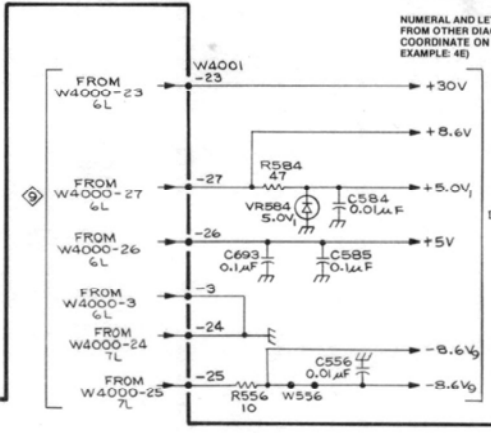

SEE POWER DISTRIBUTION

3826-40 REV OCT 1981

ALTERNATE B SWEEP

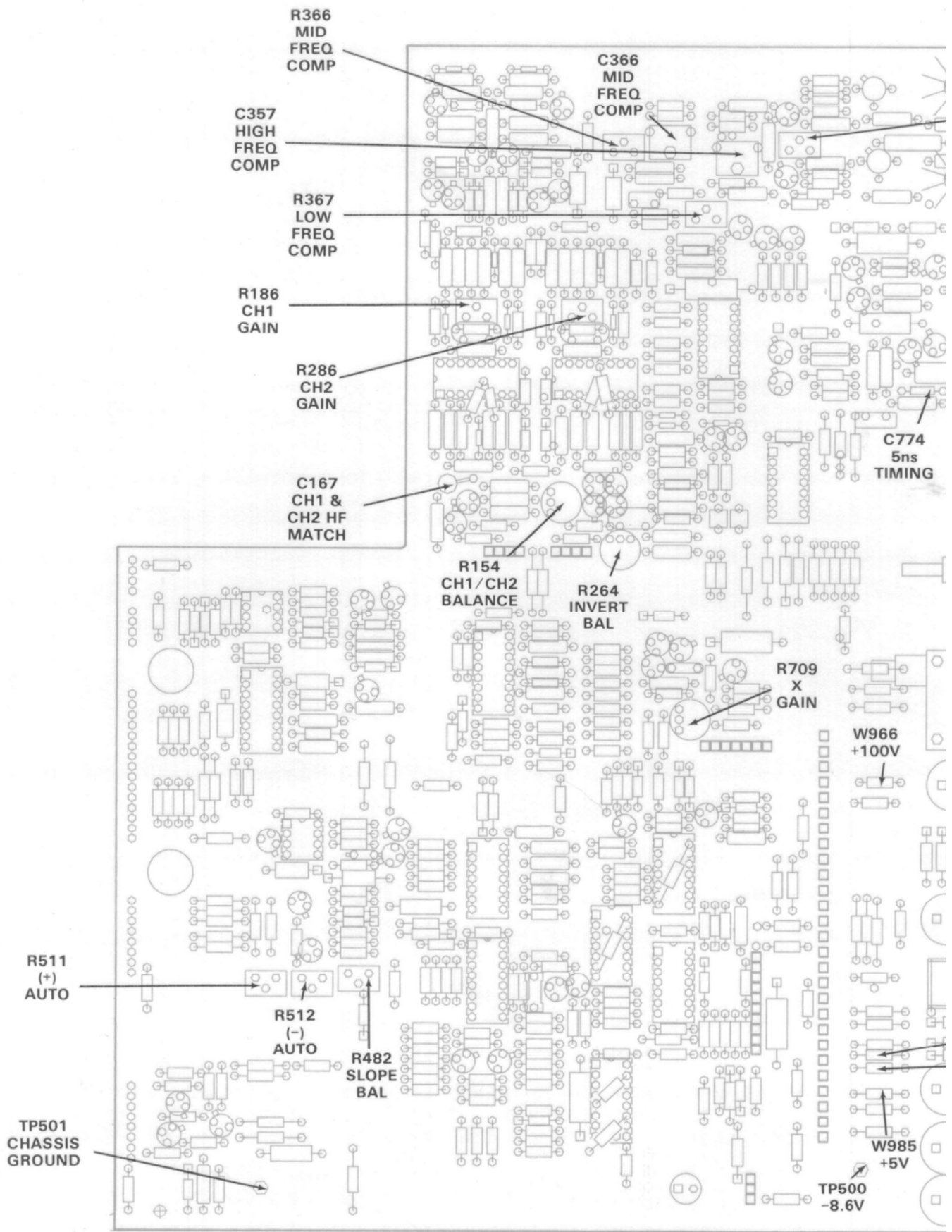

A10—MAIN BOARD ADJUSTMENT LOCAT

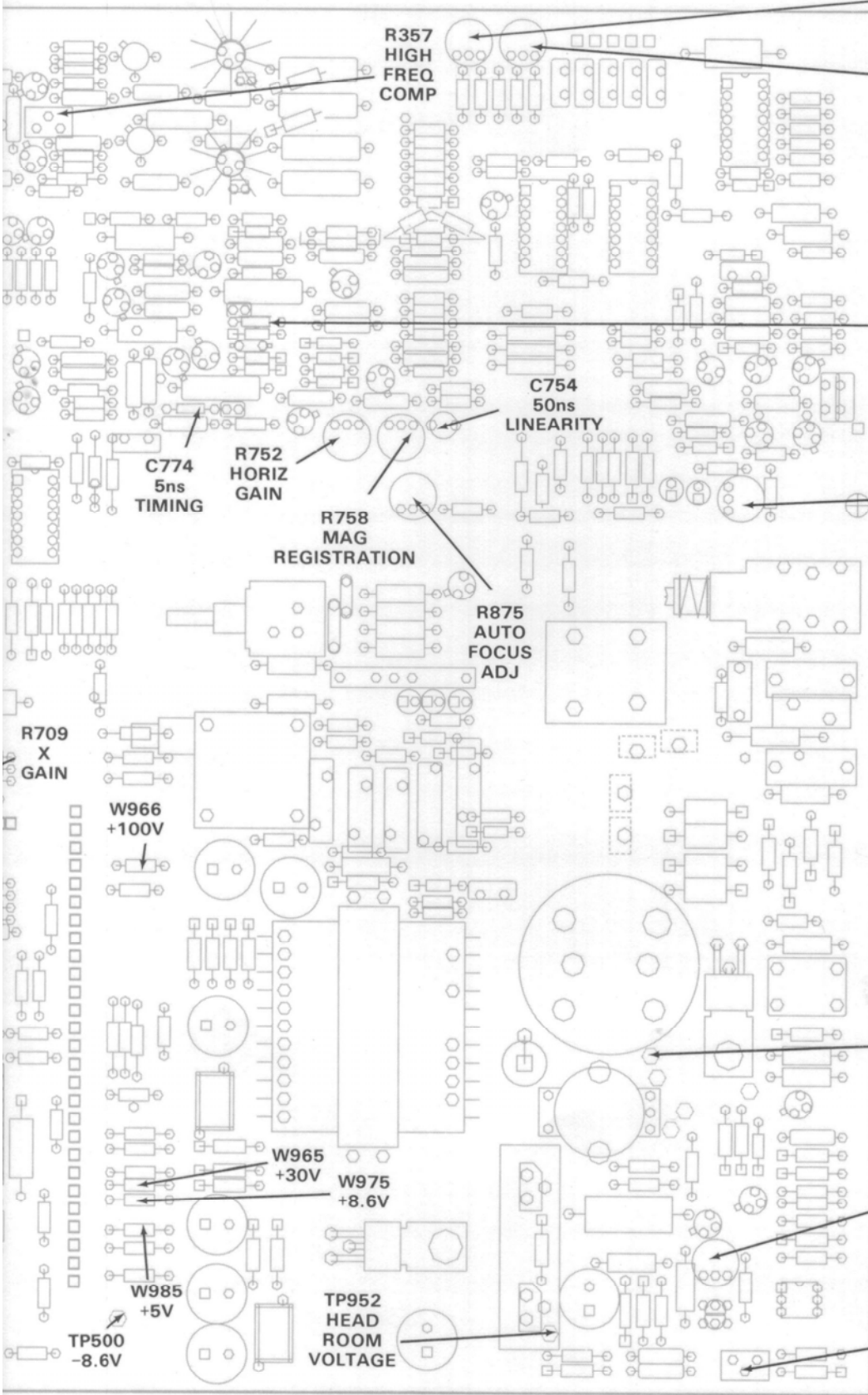

R887  
ASTIG

R870  
GEOM

C784  
5ns  
TIMING

C754  
50ns  
LINEARITY

C774  
5ns  
TIMING

R752  
HORIZ  
GAIN

R758  
MAG  
REGISTRATION

R875  
AUTO  
FOCUS  
ADJ

R860  
GRID  
BIAS

R709  
X  
GAIN

W966  
+100V

W965  
+30V

W975  
+8.6V

W985  
+5V

TP500  
-8.6V

TP952  
HEAD  
ROOM  
VOLTAGE

TP934  
COMMON

R952  
HEAD  
ROOM  
VOLTAGE  
ADJUST

R946  
-8.6V  
ADJ

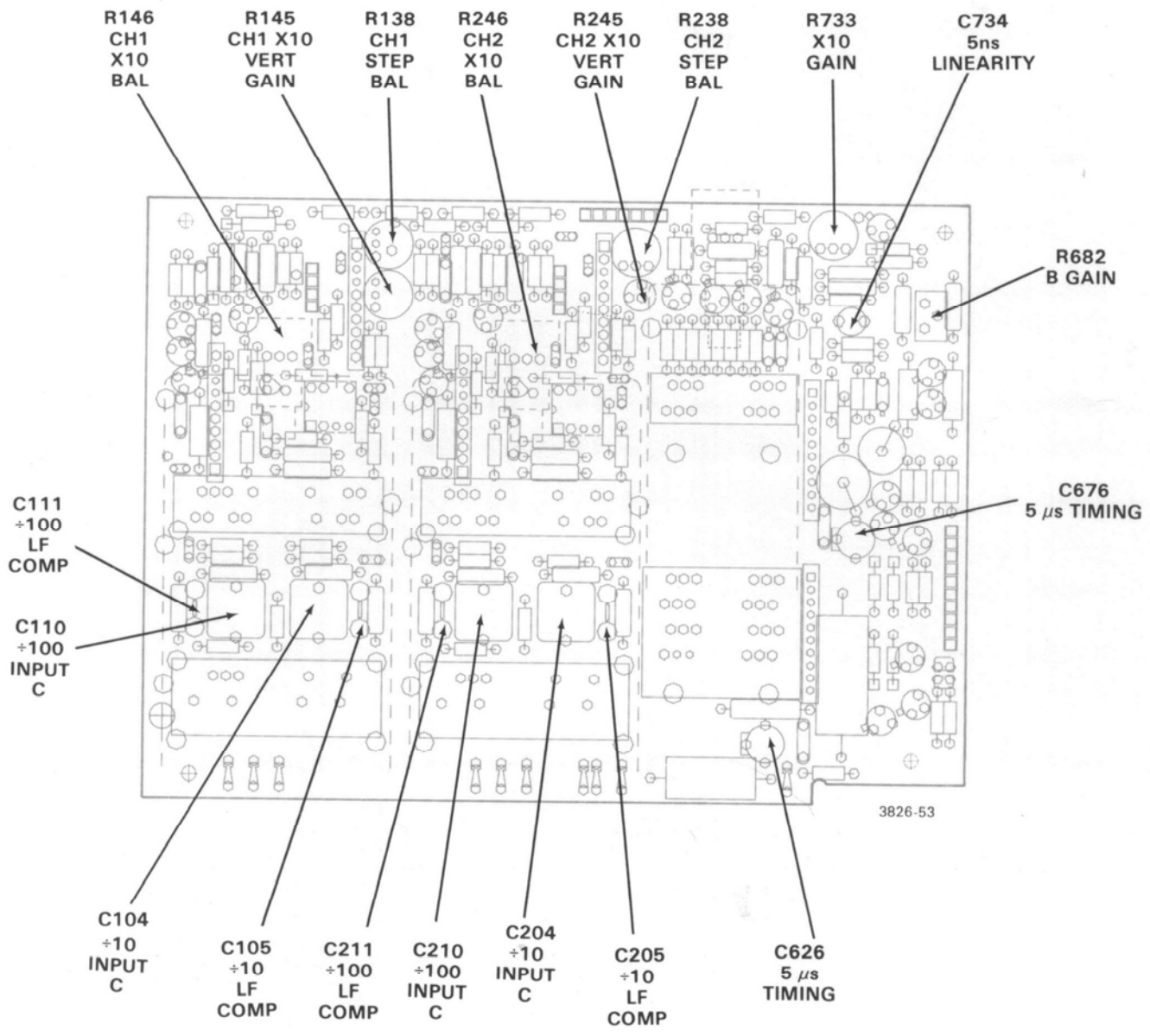

A12—ATTENUATOR/SWEEP AND A13—

@

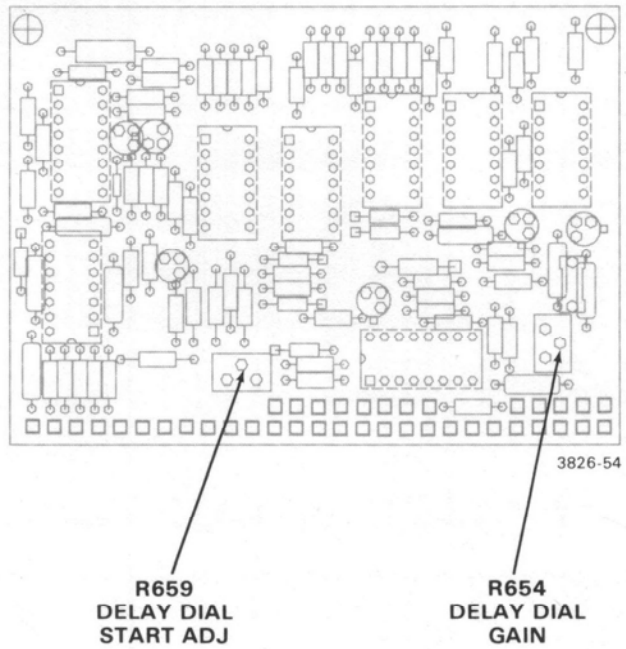

**ALT SWEEP BOARDS ADJUSTMENT LOCATIONS**

## GENERAL NOTES

- A. Use schematic diagrams, the overall block diagram, circuit board illustrations, and circuit descriptions when analyzing instrument malfunctions and locating test points. The schematic diagrams include typical waveforms and voltages that are intended as an aid in troubleshooting.
- B. Always set the POWER switch to OFF and unplug the line cord before swapping, removing, or replacing components, and before connecting or disconnecting instrument leads and cables.
- C. When analyzing circuit malfunctions, consider connectors and cables as possible causes of failure.

## SPECIFIC NOTES

1. Set initial front-panel controls as follows:

VERTICAL MODE	CH 1
VOLTS/DIV	0.1V
VOLTS/DIV Variable	Cal detent
AC-GND-DC	AC
Vertical POSITION	Midrange
A TRIGGER MODE	AUTO
A & B INT	VERT MODE
A SOURCE	INT
A SEC/DIV	0.1ms
A SEC/DIV Variable	Cal detent
X10 Magnification	Off (Cal button in)
AUTO INTENSITY	Midrange
AUTO FOCUS	Midrange
Horizontal POSITION	Midrange
POWER Switch	Off (button out)

2. Verify the low-voltage power supplies at the following test points:

SUPPLY	TEST POINT	TOLERANCE
-8.6V	TP500	-8.56 to -8.64V
+8.6V	W975	8.34 to 8.86V
+5V	W985	4.75 to 5.25V
+30V	W965	28.5 to 31.5V
+100V	W966	95 to 105V

### NOTE

A HV probe is required to measure the -2kV supply. Turn off the power and make the test equipment connections to the oscilloscope. Set the voltmeter to read at least -3kV, then turn the oscilloscope power back on to take the reading. After obtaining the reading, turn off the oscilloscope power to disconnect the test equipment connections, and replace the crt socket cover.

Verify the -2kV supply at pin 2 of the crt socket. The voltage should be between -1900 and -2100V.

### WARNING

3.

The Preregulator and Inverter circuits have a floating common reference with respect to chassis ground. Ac-source potential is present on the common reference points. Connect the instrument to the ac-power source through an isolation transformer to prevent the possibility of personal injury or equipment damage when troubleshooting these circuits. When an autotransformer is also used in the troubleshooting procedure, connect the isolation transformer to the ac-power source, then connect the autotransformer to the isolation transformer. Finally, plug the instrument power cord into the autotransformer outlet.

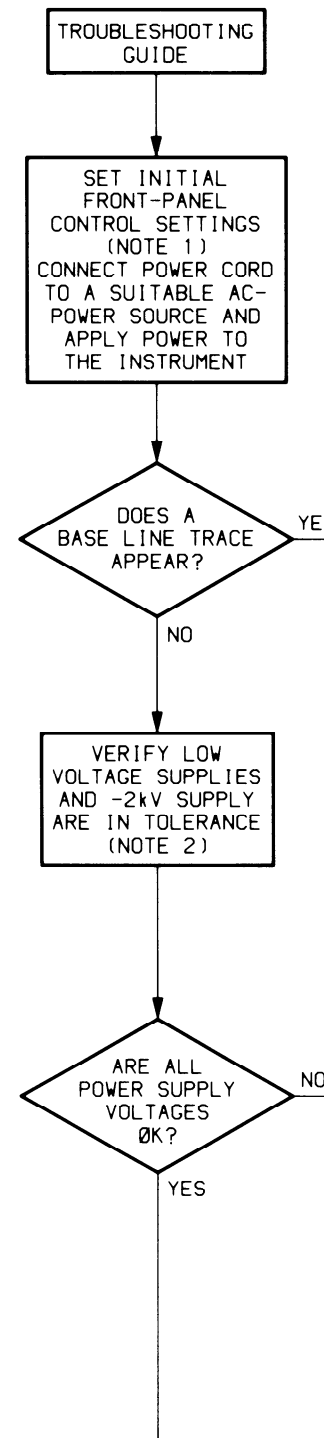

\* NUMBER IN SCHEMATIC

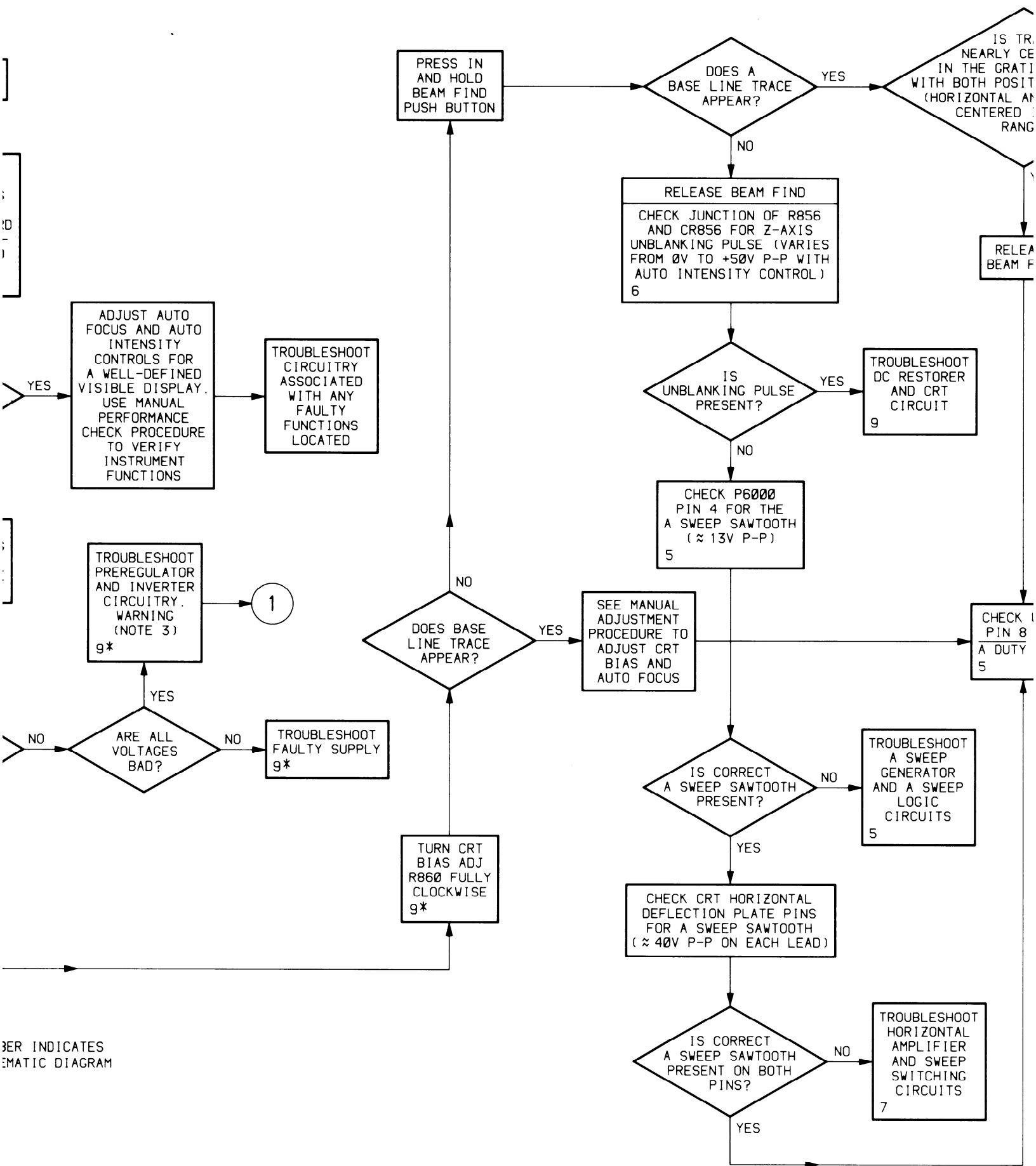

3ER INDICATES  
EMATIC DIAGRAM

@



## GENERAL NOTES

- Use schematic diagrams, the overall block diagram, circuit board illustrations, and circuit descriptions when analyzing instrument malfunctions and locating test points. The schematic diagrams include typical waveforms and voltages that are intended as an aid in troubleshooting.
- Always set the POWER switch to OFF and unplug the line cord before swapping, removing, or replacing components, and before connecting or disconnecting instrument leads and cables.
- When analyzing circuit malfunctions, consider connectors and cables as possible causes of failure.

## SPECIFIC NOTES

- Set initial front-panel controls as follows:

VERTICAL MODE	CH 1
VOLTS/DIV	0.1V
VOLTS/DIV Variable	Cal detent
AC-GND-DC	AC
Vertical POSITION	Midrange
A TRIGGER MODE	AUTO
A & B INT	VERT MODE
A SOURCE	INT
A SEC/DIV	0.1ms
A SEC/DIV Variable	Cal detent
X10 Magnification	Off (Cal button in)
AUTO INTENSITY	Midrange
AUTO FOCUS	Midrange
Horizontal POSITION	Midrange
POWER Switch	Off (button out)

- Verify the low-voltage power supplies at the following test points:

SUPPLY	TEST POINT	TOLERANCE
-8.6V	TP500	-8.56 to -8.64V
+8.6V	W975	8.34 to 8.86V
+5V	W985	4.75 to 5.25V
+30V	W965	28.5 to 31.5V
+100V	W966	95 to 105V

### NOTE

A HV probe is required to measure the -2kV supply. Turn off the power and make the test equipment connections to the oscilloscope. Set the voltmeter to read at least -3kV, then turn the oscilloscope power back on to take the reading. After obtaining the reading, turn off the oscilloscope power to disconnect the test equipment connections, and replace the crt socket cover.

Verify the -2kV supply at pin 2 of the crt socket. The voltage should be between -1900 and -2100V.

### WARNING

3.

The Preregulator and Inverter circuits have a floating common reference with respect to chassis ground. Ac-source potential is present on the common reference points. Connect the instrument to the ac-power source through an isolation transformer to prevent the possibility of personal injury or equipment damage when troubleshooting these circuits. When an autotransformer is also used in the troubleshooting procedure, connect the isolation transformer to the ac-power source, then connect the autotransformer to the isolation transformer. Finally, plug the instrument power cord into the autotransformer outlet.

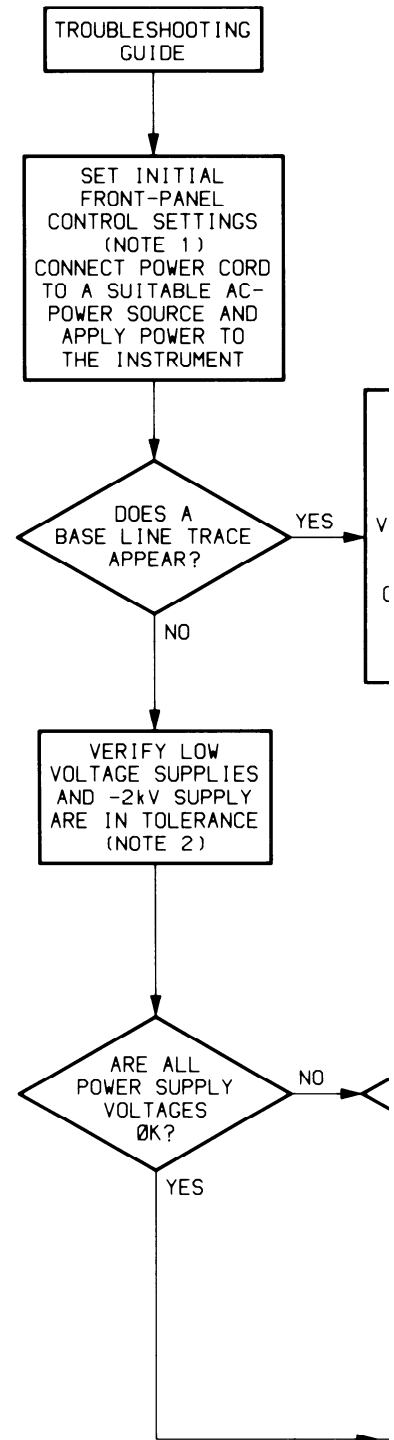

\* NUMBER INDICAT  
SCHEMATIC DIAC

## GENERAL NOTES

- A. Use schematic diagrams, the overall block diagram, circuit board illustrations, and circuit descriptions when analyzing instrument malfunctions and locating test points. The schematic diagrams include typical waveforms and voltages that are intended as an aid in troubleshooting.
- B. Always set the POWER switch to OFF and unplug the line cord before swapping, removing, or replacing components, and before connecting or disconnecting instrument leads and cables.
- C. When analyzing circuit malfunctions, consider connectors and cables as possible causes of failure.

## SPECIFIC NOTES

### **WARNING**

1. The Preregulator and Inverter circuits have a floating common reference with respect to chassis ground. Ac-source potential is present on the common reference points. Connect the instrument to the ac-power source through an isolation transformer to prevent the possibility of personal injury or equipment damage when troubleshooting these circuits. When an autotransformer is also used in the troubleshooting procedure, connect the isolation transformer to the ac-power source, then connect the autotransformer to the isolation transformer. Finally, plug the instrument power cord into the autotransformer outlet.

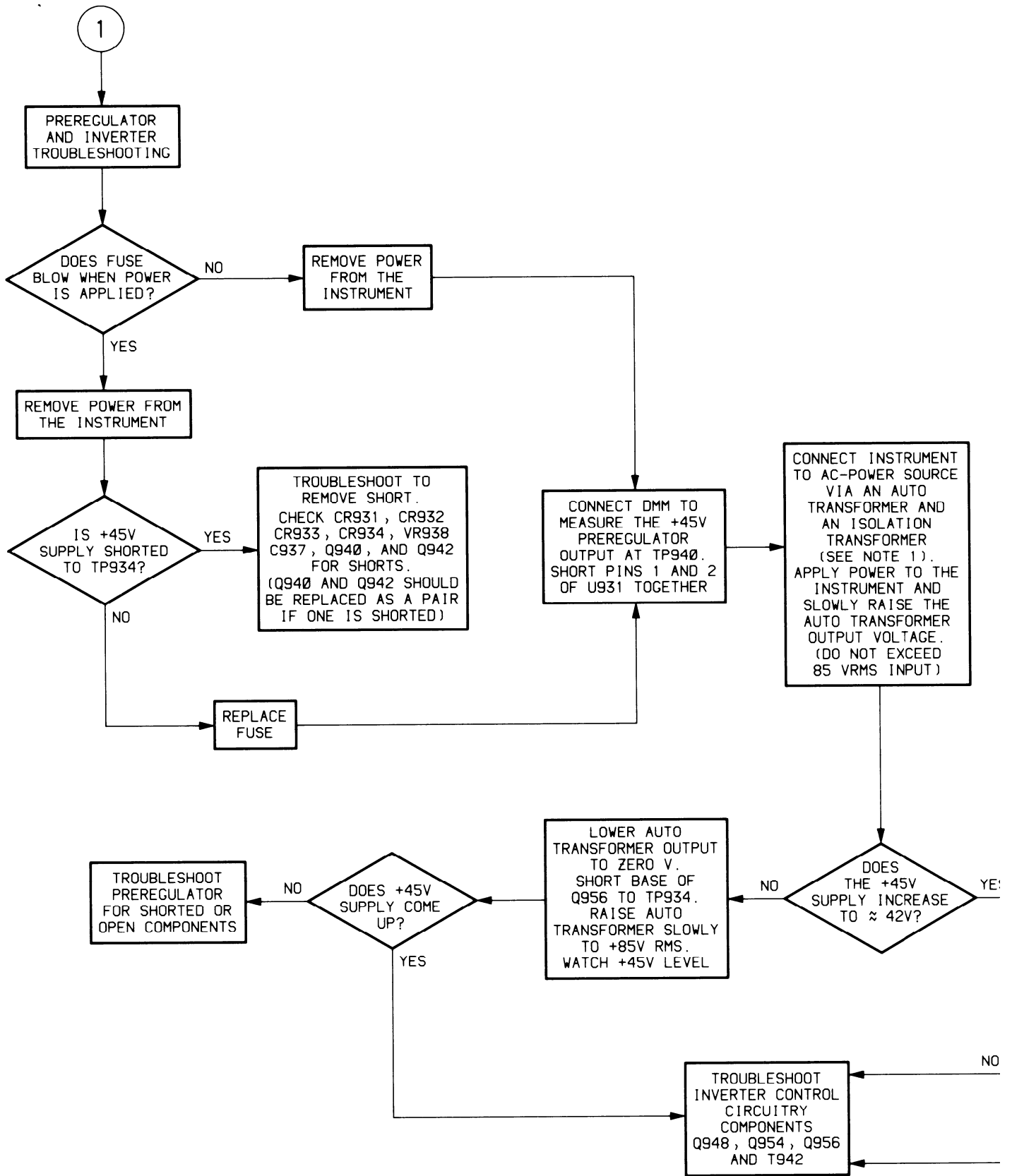

TR  
SUP  
C+

@

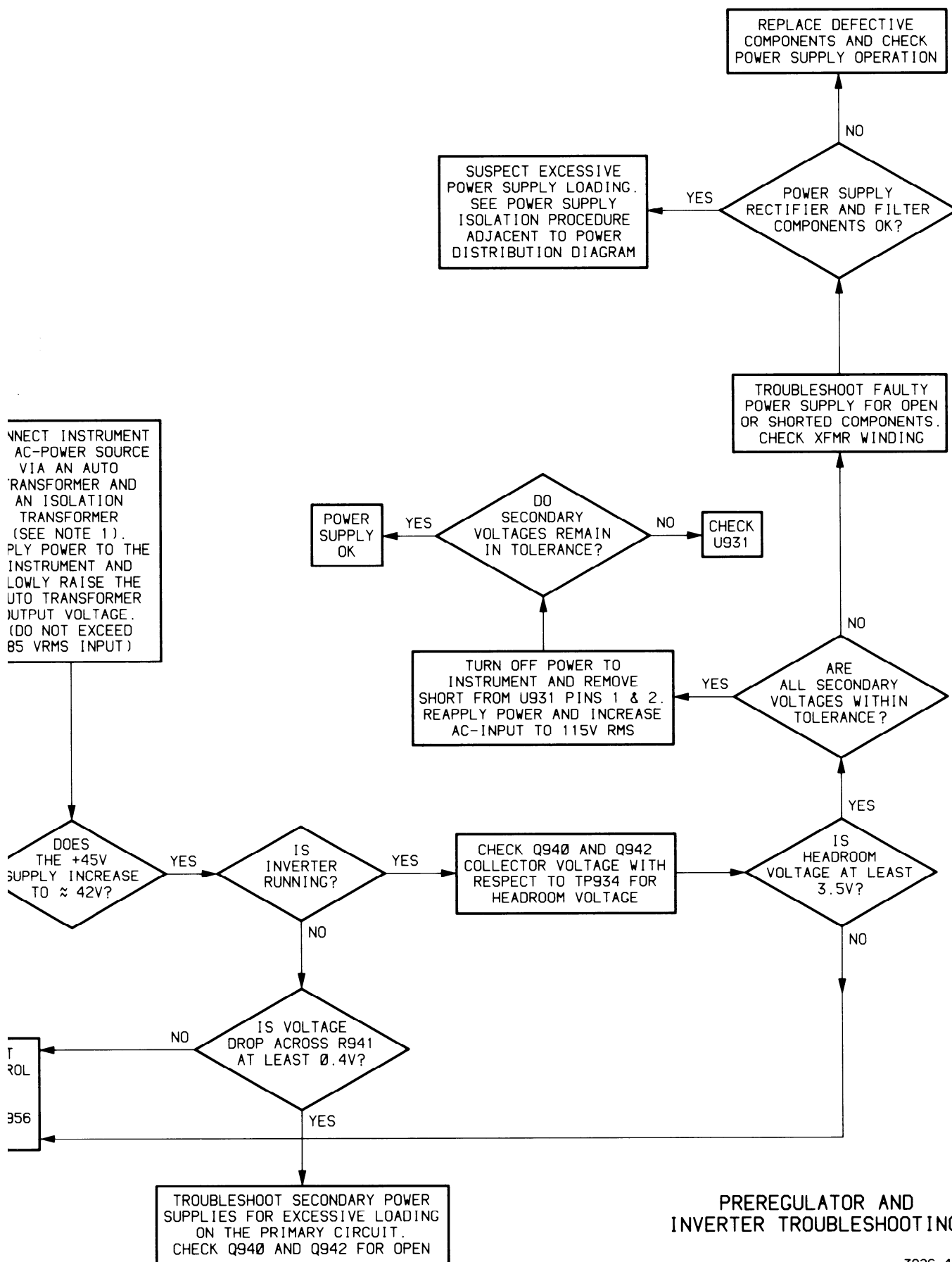

PREREGULATOR AND INVERTER TROUBLESHOOTING

# REPLACEABLE MECHANICAL PARTS

## PARTS ORDERING INFORMATION

Replacement parts are available from or through your local Tektronix, Inc. Field Office or representative.

Changes to Tektronix instruments are sometimes made to accommodate improved components as they become available, and to give you the benefit of the latest circuit improvements developed in our engineering department. It is therefore important, when ordering parts, to include the following information in your order: Part number, instrument type or number, serial number, and modification number if applicable.

If a part you have ordered has been replaced with a new or improved part, your local Tektronix, Inc. Field Office or representative will contact you concerning any change in part number.

Change information, if any, is located at the rear of this manual.

## SPECIAL NOTES AND SYMBOLS

- X000 Part first added at this serial number
- 00X Part removed after this serial number

## FIGURE AND INDEX NUMBERS

Items in this section are referenced by figure and index numbers to the illustrations.

## INDENTATION SYSTEM

This mechanical parts list is indented to indicate item relationships. Following is an example of the indentation system used in the description column.

- ```

1 2 3 4 5           Name & Description
Assembly and/or Component
Attaching parts for Assembly and/or Component
    --- * ---
Detail Part of Assembly and/or Component
Attaching parts for Detail Part
    --- * ---
Parts of Detail Part
Attaching parts for Parts of Detail Part
    --- * ---
    
```

Attaching Parts always appear in the same indentation as the item it mounts, while the detail parts are indented to the right. Indented items are part of, and included with, the next higher indentation. The separation symbol --- \* --- indicates the end of attaching parts.

**Attaching parts must be purchased separately, unless otherwise specified.**

## ITEM NAME

In the Parts List, an Item Name is separated from the description by a colon (:). Because of space limitations, an Item Name may sometimes appear as incomplete. For further Item Name identification, the U.S. Federal Cataloging Handbook H6-1 can be utilized where possible.

## ABBREVIATIONS

|       |                    |         |                       |          |                      |         |                 |
|-------|--------------------|---------|-----------------------|----------|----------------------|---------|-----------------|
| ..    | INCH               | ELCTRN  | ELECTRON              | IN       | INCH                 | SE      | SINGLE END      |
| #     | NUMBER SIZE        | ELEC    | ELECTRICAL            | INCAND   | INCANDESCENT         | SECT    | SECTION         |
| ACTR  | ACTUATOR           | ELCTLT  | ELECTROLYTIC          | INSUL    | INSULATOR            | SEMICON | SEMICONDUCTOR   |
| ADPTR | ADAPTER            | ELEM    | ELEMENT               | INTL     | INTERNAL             | SHLD    | SHIELD          |
| ALIGN | ALIGNMENT          | EPL     | ELECTRICAL PARTS LIST | LPHLDR   | LAMPHOLDER           | SHLDR   | SHOULDERED      |
| AL    | ALUMINUM           | EQPT    | EQUIPMENT             | MACH     | MACHINE              | SKT     | SOCKET          |
| ASSEM | ASSEMBLED          | EXT     | EXTERNAL              | MECH     | MECHANICAL           | SL      | SLIDE           |
| ASSY  | ASSEMBLY           | FIL     | FILLISTER HEAD        | MTG      | MOUNTING             | SLFLKGG | SELF-LOCKING    |
| ATTEN | ATTENUATOR         | FLEX    | FLEXIBLE              | NIP      | NIPPLE               | SLVG    | SLEEVING        |
| AWG   | AMERICAN WIRE GAGE | FLH     | FLAT HEAD             | NON WIRE | NOT WIRE WOUND       | SPR     | SPRING          |
| BD    | BOARD              | FLTR    | FILTER                | OBD      | ORDER BY DESCRIPTION | SQ      | SQUARE          |
| BRKT  | BRACKET            | FR      | FRAME or FRONT        | OD       | OUTSIDE DIAMETER     | SST     | STAINLESS STEEL |
| BRS   | BRASS              | FSTNR   | FASTENER              | OVH      | OVAL HEAD            | STL     | STEEL           |
| BRZ   | BRONZE             | FT      | FOOT                  | PH BRZ   | PHOSPHOR BRONZE      | SW      | SWITCH          |
| BSHG  | BUSHING            | FXD     | FIXED                 | PL       | PLAIN or PLATE       | T       | TUBE            |
| CAB   | CABINET            | GSKT    | GASKET                | PLSTC    | PLASTIC              | TERM    | TERMINAL        |
| CAP   | CAPACITOR          | HDL     | HANDLE                | PN       | PART NUMBER          | THD     | THREAD          |
| CER   | CERAMIC            | HEX     | HEXAGON               | PNH      | PAN HEAD             | THK     | THICK           |
| CHAS  | CHASSIS            | HEX HD  | HEXAGONAL HEAD        | PWR      | POWER                | TNSN    | TENSION         |
| CKT   | CIRCUIT            | HEX SOC | HEXAGONAL SOCKET      | RCPT     | RECEPTACLE           | TPG     | TAPPING         |
| COMP  | COMPOSITION        | HLCPS   | HELICAL COMPRESSION   | RES      | RESISTOR             | TRH     | TRUSS HEAD      |
| CONN  | CONNECTOR          | HLEXT   | HELICAL EXTENSION     | RGD      | RIGID                | V       | VOLTAGE         |
| COV   | COVER              | HV      | HIGH VOLTAGE          | RLF      | RELIEF               | VAR     | VARIABLE        |
| CPLG  | COUPLING           | IC      | INTEGRATED CIRCUIT    | RTNR     | RETAINER             | W       | WITH            |
| CRT   | CATHODE RAY TUBE   | ID      | INSIDE DIAMETER       | SCH      | SOCKET HEAD          | WSHR    | WASHER          |
| DEG   | DEGREE             | IDENT   | IDENTIFICATION        | SCOPE    | OSCILLOSCOPE         | XFMR    | TRANSFORMER     |
| DWR   | DRAWER             | IMPLR   | IMPELLER              | SCR      | SCREW                | XSTR    | TRANSISTOR      |

CROSS INDEX—MFR. CODE NUMBER TO MANUFACTURER

| Mfr. Code | Manufacturer                                                | Address                | City, State, Zip         |
|-----------|-------------------------------------------------------------|------------------------|--------------------------|
| S3629     | PANEL COMPONENTS CORP.                                      | 2015 SECOND ST.        | BERKELEY, CA 94170       |
| 00779     | AMP, INC.                                                   | P O BOX 3608           | HARRISBURG, PA 17105     |
| 01536     | CAMCAR DIV OF TEXTRON INC. SEMS PRODUCTS UNIT               | 1818 CHRISTINA ST.     | ROCKFORD, IL 61108       |
| 02768     | ILLINOIS TOOL WORKS, INC., FASTEX DIV.                      | 195 ALGONQUIN ROAD     | DES PLAINES, IL 60016    |
| 05129     | KILO ENGINEERING COMPANY                                    | 2015 D                 | LA VERNE, CA 91750       |
| 05820     | WAKEFIELD ENGINEERING, INC.                                 | AUDUBON ROAD           | WAKEFIELD, MA 01880      |
| 16428     | BELDEN CORP.                                                | P. O. BOX 1331         | RICHMOND, IN 47374       |
| 22526     | BERG ELECTRONICS, INC.                                      | YOUK EXPRESSWAY        | NEW CUMBERLAND, PA 17070 |
| 23050     | PRODUCT COMPONENTS CORP                                     | 30 LORRAINE AVE.       | MT VERNON, NY 10553      |
| 24931     | SPECIALITY CONNECTOR CO., INC.                              | 2620 ENDRESS PLACE     | GREENWOOD, IN 46142      |
| 28520     | HEYMAN MFG. CO.                                             | 147 N. MICHIGAN AVE.   | KENILWORTH, NJ 07033     |
| 71279     | CAMBRIDGE THERMIONIC CORP.                                  | 445 CONCORD AVE.       | CAMBRIDGE, MA 02138      |
| 71400     | BUSSMAN MFG., DIVISION OF MCGRAW-EDISON CO.                 | 2536 W. UNIVERSITY ST. | ST. LOUIS, MO 63107      |
| 73743     | FISCHER SPECIAL MFG. CO.                                    | 446 MORGAN ST.         | CINCINNATI, OH 45206     |
| 77250     | PHEOLL MANUFACTURING CO., DIVISION OF ALLIED PRODUCTS CORP. | 5700 W. ROOSEVELT RD.  | CHICAGO, IL 60650        |
| 78189     | ILLINOIS TOOL WORKS, INC. SHAKEPROOF DIVISION               | ST. CHARLES ROAD       | ELGIN, IL 60120          |
| 79807     | WROUGHT WASHER MFG. CO.                                     | 2100 S. O BAY ST.      | MILWAUKEE, WI 53207      |
| 80009     | TEKTRONIX, INC.                                             | P O BOX 500            | BEAVERTON, OR 97077      |
| 83385     | CENTRAL SCREW CO.                                           | 2530 CRESCENT DR.      | BROADVIEW, IL 60153      |
| 83486     | ELCO INDUSTRIES, INC.                                       | 1103 SAMUELSON ROAD    | ROCKFORD, IL 61101       |
| 89663     | REESE, J. RAMSEY, INC.                                      | 71 MURRAY STREET       | NEW YORK, NY 10007       |
| 93907     | TEXTRON INC. CAMCAR DIV                                     | 600 18TH AVE           | ROCKFORD, IL 61101       |

Replaceable Mechanical Parts—2215 Service

| Fig. & Index No. | Tektronix Part No. | Serial/Model No. Eff Dscont | Qty | 1 | 2 | 3 | 4 | 5 | Name & Description                                            | Mfr Code | Mfr Part Number  |
|------------------|--------------------|-----------------------------|-----|---|---|---|---|---|---------------------------------------------------------------|----------|------------------|
| 1-1              | 334-5001-00        |                             | 1   |   |   |   |   |   | MARKER, IDENT:MKD CAUTION                                     | 80009    | 334-5001-00      |
| -2               | 200-2538-00        |                             | 1   |   |   |   |   |   | COVER, REAR:PLASTIC<br>(ATTACHING PARTS)                      | 80009    | 200-2538-00      |
| -3               | 211-0691-00        |                             | 2   |   |   |   |   |   | SCREW, MACHINE:6-32 X 0.625, PNH<br>- - - * - - -             | 01536    | OBD              |
| -4               | 390-0790-00        |                             | 1   |   |   |   |   |   | CABINET, SCOPE:<br>(ATTACHING PARTS)                          | 80009    | 390-0790-00      |
| -5               | 213-0882-00        |                             | 1   |   |   |   |   |   | SCREW, TAPPING:6-32 X 0.437 TYPE C<br>- - - * - - -           | 01536    | OBD              |
| -6               | 348-0659-00        |                             | 2   |   |   |   |   |   | FOOT, CABINET:BLACK POLYURETHANE                              | 80009    | 348-0659-00      |
| -7               | 334-4170-00        |                             | 1   |   |   |   |   |   | MARKER, IDENT:                                                | 80009    | 334-4170-00      |
| -8               | 367-0289-00        |                             | 1   |   |   |   |   |   | HANDLE, CARRYING:13.855, SST<br>(ATTACHING PARTS)             | 80009    | 367-0289-00      |
| -9               | 212-0144-00        |                             | 2   |   |   |   |   |   | SCREW, TPG, TF:8-16 X 0.562 L<br>- - - * - - -                | 93907    | 225-38131-012    |
| -10              | 334-5002-00        |                             | 1   |   |   |   |   |   | PLATE, IDENT:MKD TEKTRONIX                                    | 80009    | 334-5002-00      |
| -11              | 426-1765-00        |                             | 1   |   |   |   |   |   | FRAME, CRT:<br>(ATTACHING PARTS)                              | 80009    | 426-1765-00      |
| -12              | 211-0690-00        |                             | 2   |   |   |   |   |   | SCREW, MACHINE:6-32 X 0.875, PNH, STL<br>- - - * - - -        | 01536    | OBD              |
| -13              | 337-2775-00        |                             | 1   |   |   |   |   |   | SHLD, IMPLOSION:                                              | 80009    | 337-2775-00      |
| -14              | 366-1833-00        |                             | 7   |   |   |   |   |   | KNOB:GRAY, 0.25 ID X 0.392 X 0.392OD                          | 80009    | 366-1833-00      |
| -15              | 366-1701-00        | B010100 B010404             | 1   |   |   |   |   |   | KNOB:GY, 0.127 ID X 0.392 OD X 0.4                            | 80009    | 366-1701-00      |
|                  | 366-1701-01        | B010405                     | 1   |   |   |   |   |   | KNOB:GY, 0.127 ID X 0.392 OD X 0.4                            | 80009    | 366-1701-01      |
| -16              | -----              |                             | 1   |   |   |   |   |   | RES, VAR, NONWW:(SEE R647 REPL)<br>(ATTACHING PARTS)          |          |                  |
| -17              | 210-0583-00        |                             | 1   |   |   |   |   |   | NUT, PLAIN, HEX.:0.25-32 X 0.312 INCH, BRS                    | 73743    | 2X20317-402      |
| -18              | 210-0940-00        |                             | 1   |   |   |   |   |   | WASHER, FLAT:0.25 ID X 0.375 INCH OD, STL                     | 79807    | OBD              |
|                  | 210-0021-00        | XB010405                    | 1   |   |   |   |   |   | WASHER, LOCK:INTL, 0.476 ID X 0.60"OD STL<br>- - - * - - -    | 78189    | 1222-01-00-0541C |
| -19              | -----              |                             | 2   |   |   |   |   |   | CONNECTOR, RCPT, :(SEE J1001, J2001 REPL)                     |          |                  |
| -20              | -----              |                             | 1   |   |   |   |   |   | CONN, RCPT, ELEC:(SEE J4001 REPL)                             |          |                  |
| -21              | 210-0255-00        |                             | 1   |   |   |   |   |   | TERMINAL, LUG:0.391" ID INT TOOTH                             | 80009    | 210-0255-00      |
| -22              | 384-1575-00        |                             | 1   |   |   |   |   |   | EXTENSION, SHAFT:FOCUS W/KNOB, PLASTIC                        | 80009    | 384-1575-00      |
| -23              | 358-0550-00        |                             | 1   |   |   |   |   |   | BUSHING, SHAFT:0.15 ID X 0.31 INCH OD, PLSTC                  | 80009    | 358-0550-00      |
| -24              | 136-0387-01        |                             | 1   |   |   |   |   |   | JACK, TIP:BLACK                                               | 71279    | 450-4252-01-0310 |
| -25              | 366-1031-03        |                             | 1   |   |   |   |   |   | KNOB:RED--CAL                                                 | 80009    | 366-1031-03      |
| -26              | 366-1838-01        |                             | 1   |   |   |   |   |   | KNOB:GY, 0.249 ID X 0.718 X 1.765                             | 80009    | 366-1838-01      |
| -27              | 358-0640-00        |                             | 1   |   |   |   |   |   | BSHG, MACH THD:0.5-32 THD X 0.39 ID                           | 80009    | 358-0640-00      |
| -28              | 366-1405-08        |                             | 1   |   |   |   |   |   | KNOB:RED, CAL, 0.082ID X 0.45 OD                              | 80009    | 366-1405-08      |
| -29              | 366-1840-00        |                             | 1   |   |   |   |   |   | KNOB:GY, TIME/DIV, 0.127 ID X 0.855                           | 80009    | 366-1840-00      |
| -30              | 366-1850-00        |                             | 1   |   |   |   |   |   | KNOB:CLEAR, 0.252 ID X 1.2 OD X 0.383                         | 80009    | 366-1850-00      |
| -31              | 331-0328-00        |                             | 1   |   |   |   |   |   | DIAL, CONTROL:10 TURN FOR 0.25 DIA SHAFT                      | 05129    | 461-S-70         |
| -32              | 210-0840-00        |                             | 1   |   |   |   |   |   | WASHER, FLAT:0.39 ID X 0.562 INCH OD, STL                     | 89663    | 644R             |
| -33              | -----              |                             | 1   |   |   |   |   |   | RES, VAR, WW:(SEE R658 REPL)                                  |          |                  |
| -34              | 333-2679-00        |                             | 1   |   |   |   |   |   | PANEL, FRONT:                                                 | 80009    | 333-2679-00      |
| -35              | 366-2013-00        |                             | 2   |   |   |   |   |   | PUSH, BUTTON:DIRTY GRAY, 0.134 SQ X 0.480 H                   | 80009    | 366-2013-00      |
| -36              | 348-0660-00        |                             | 4   |   |   |   |   |   | CUSHION, CRT:POLYURETHANE                                     | 80009    | 348-0660-00      |
| -37              | 386-4444-00        |                             | 1   |   |   |   |   |   | SUBPANEL, FRONT:<br>(ATTACHING PARTS)                         | 80009    | 386-4444-00      |
| -38              | 213-0881-00        |                             | 4   |   |   |   |   |   | SCREW, TAPPING:6-32 X 0.25 TYPE C                             | 01536    | OBD              |
| -39              | 213-0882-00        |                             | 2   |   |   |   |   |   | SCREW, TAPPING:6-32 X 0.437 TYPE C<br>- - - * - - -           | 01536    | OBD              |
| -40              | 377-0512-00        |                             | 7   |   |   |   |   |   | INSERT, KNOB:0.125 ID X 0.663 L, AL                           | 80009    | 377-0512-00      |
| -41              | 129-0836-00        |                             | 2   |   |   |   |   |   | SPACER, POST:1.207 L, W/0.5-32 THD                            | 80009    | 129-0836-00      |
| -42              | 384-1503-00        |                             | 2   |   |   |   |   |   | EXTENSION SHAFT:5.4 L X 0.124DIA, PLASTIC                     | 80009    | 384-1503-00      |
| -43              | 384-1323-00        |                             | 1   |   |   |   |   |   | EXTENSION SHAFT:6.4 L X 0.081OD SST                           | 80009    | 384-1323-00      |
| -44              | -----              |                             | 1   |   |   |   |   |   | CKT BOARD ASSY:ATTEN/SWEEP(SEE A12 REPL)<br>(ATTACHING PARTS) |          |                  |
| -45              | 211-0304-00        |                             | 2   |   |   |   |   |   | SCREW, MACHINE:4-40 X 0.312, PNH<br>- - - * - - -             | 01536    | OBD              |
| -46              | -----              |                             | -   |   |   |   |   |   | CKT BOARD ASSY INCLUDES:                                      |          |                  |
|                  | -----              |                             | 25  |   |   |   |   |   | . TERMINAL, PIN:(SEE A12P1010, P2010, P6001,                  |          |                  |
|                  | -----              |                             | -   |   |   |   |   |   | . P7000 REPL)                                                 |          |                  |
| -47              | 136-0328-02        |                             | 10  |   |   |   |   |   | . SOCKET, PIN TERM:HORIZONTAL                                 | 00779    | 86282-2          |

**Replaceable Mechanical Parts—2215 Service**

| Fig. & Index No. | Tektronix Part No. | Serial/Model No. Eff Dscont | Qty | 1 | 2                                                | 3 | 4 | 5 | Name & Description | Mfr Code | Mfr Part Number  |
|------------------|--------------------|-----------------------------|-----|---|--------------------------------------------------|---|---|---|--------------------|----------|------------------|
| 1-48             | -----              | -----                       | 1   | . | RES,VAR, NONWIR:(SEE A12S734, R629 REPL)         |   |   |   | (ATTACHING PARTS)  |          |                  |
| -49              | 210-0413-00        |                             | 1   | . | NUT, PLAIN, HEX.:0.375-32 X 0.50 INCH, STL       |   |   |   |                    | 73743    | 3145-402         |
| -50              | 210-0012-00        |                             | 1   | . | WASHER, LOCK:INTL, 0.375 ID X 0.50" OD STL       |   |   |   |                    | 78189    | 1220-02-00-0541C |
|                  |                    |                             |     |   | - - - * - - -                                    |   |   |   |                    |          |                  |
| -51              | -----              | -----                       | 1   | . | SWITCH, ROTARY:(SEE A12S630A, B, C REPL)         |   |   |   |                    |          |                  |
| -52              | -----              | -----                       | 2   | . | RES, VAR, NONWIR:(SEE A12R141, R241 REPL)        |   |   |   | (ATTACHING PARTS)  |          |                  |
| -53              | 210-0413-00        |                             | 1   | . | NUT, PLAIN, HEX.:0.375-32 X 0.50 INCH, STL       |   |   |   |                    | 73743    | 3145-402         |
| -54              | 210-0012-00        |                             | 1   | . | WASHER, LOCK:INTL, 0.375 ID X 0.50" OD STL       |   |   |   |                    | 78189    | 1220-02-00-0541C |
|                  |                    |                             |     |   | - - - * - - -                                    |   |   |   |                    |          |                  |
| -55              | -----              | -----                       | 2   | . | SWITCH, ROTARY:(SEE A12S105, S205 REPL)          |   |   |   |                    |          |                  |
| -56              | 407-2585-00        |                             | 1   |   | BRACKET, GROUND:CIRCUIT BOARD, BRASS             |   |   |   |                    | 80009    | 407-2585-00      |
| -57              | 337-2892-00        |                             | 1   |   | SHIELD, ELEC:CIRCUIT BOARD                       |   |   |   | (ATTACHING PARTS)  | 80009    | 337-2892-00      |
| -58              | 211-0304-00        |                             | 1   |   | SCREW, MACHINE:4-40 X 0.312, PNH                 |   |   |   |                    | 01536    | OBD              |
| -59              | 129-0906-00        |                             | 1   |   | SPACER, POST:0.685 L W/4-40 INT & EXT THD        |   |   |   |                    | 80009    | 129-0906-00      |
|                  |                    |                             |     |   | - - - * - - -                                    |   |   |   |                    |          |                  |
| -60              | -----              | -----                       | 1   |   | CKT BOARD ASSY:FRONT PANEL(SEE A11 REPL)         |   |   |   | (ATTACHING PARTS)  |          |                  |
| -61              | 211-0304-00        |                             | 2   |   | SCREW, MACHINE:4-40 X 0.312, PNH                 |   |   |   |                    | 01536    | OBD              |
|                  |                    |                             |     |   | - - - * - - -                                    |   |   |   |                    |          |                  |
|                  |                    |                             |     |   | - CKT BOARD ASSY INCLUDES:                       |   |   |   |                    |          |                  |
| -62              | -----              | -----                       | 4   | . | TERMINAL, PIN:(SEE A11J1000 REPL)                |   |   |   |                    |          |                  |
| -63              | -----              | -----                       | 10  | . | TERMINAL, PIN:(SEE A11J2001 REPL)                |   |   |   |                    |          |                  |
| -64              | -----              | -----                       | 9   | . | SWITCH, SLIDE:(SEE A11S101, S201, S305, S315,    |   |   |   |                    |          |                  |
|                  |                    |                             |     |   | . . S317, S401, S440, S611, S650 REPL)           |   |   |   |                    |          |                  |
| -65              | 361-1081-00        |                             | 1   | . | SPACER, LED:PLASTIC                              |   |   |   |                    | 80009    | 361-1081-00      |
| -66              | -----              | -----                       | 1   | . | RES, VAR, NONWIR:(SEE A11R455 REPL)              |   |   |   |                    |          |                  |
| -67              | -----              | -----                       | 1   | . | RES, VAR, NONWIR:(SEE A11R557 REPL)              |   |   |   |                    |          |                  |
| -68              | -----              | -----                       | 2   | . | SWITCH, SLIDE:(SEE A11S464, S564 REPL)           |   |   |   |                    |          |                  |
| -69              | -----              | -----                       | 1   | . | SWITCH, PUSH:(SEE A11S264 REPL)                  |   |   |   |                    |          |                  |
| -70              | -----              | -----                       | 1   | . | SWITCH, PUSH:(SEE A11S390 REPL)                  |   |   |   |                    |          |                  |
| -71              | -----              | -----                       | 5   | . | RES, VAR, NONWIR:(SEE A11R190, R290, R395, R726, |   |   |   |                    |          |                  |
|                  |                    |                             |     |   | . . R807 REPL)                                   |   |   |   |                    |          |                  |
| -72              | 407-2584-00        |                             | 1   |   | BRACKET, GROUND:FRONT PANEL, BRASS               |   |   |   | (ATTACHING PARTS)  | 80009    | 407-2584-00      |
| -73              | 211-0304-00        |                             | 2   |   | SCREW, MACHINE:4-40 X 0.312, PNH                 |   |   |   |                    | 01536    | OBD              |
|                  |                    |                             |     |   | - - - * - - -                                    |   |   |   |                    |          |                  |
| -74              | 343-0089-00        |                             | 1   |   | CLAMP, LOOP:LARGE                                |   |   |   |                    | 80009    | 343-0089-00      |
| -75              | 441-1535-00        |                             | 1   |   | CHASSIS, SCOPE:FRONT MAIN                        |   |   |   | (ATTACHING PARTS)  | 80009    | 441-1535-00      |
| -76              | 213-0881-00        |                             | 2   |   | SCREW, TAPPING:6-32 X 0.25 TYPE C                |   |   |   |                    | 01536    | OBD              |
|                  |                    |                             |     |   | - - - * - - -                                    |   |   |   |                    |          |                  |
|                  | -----              | -----                       | 1   |   | TRANSISTOR:(SEE Q938 REPL)                       |   |   |   | (ATTACHING PARTS)  |          |                  |
|                  | 211-0318-00        |                             | 1   |   | SCREW, MACHINE:4-40 X 0.75, FLH, 100 DEG         |   |   |   |                    | 93907    | OBD              |
|                  | 210-0586-00        |                             | 1   |   | NUT, PL, ASSEM WA:4-40 X 0.25, STL CD PL         |   |   |   |                    | 83385    | OBD              |
|                  |                    |                             |     |   | - - - * - - -                                    |   |   |   |                    |          |                  |
|                  | 342-0582-00        |                             | 1   |   | INSULATOR, PLATE:TRANSISTOR                      |   |   |   |                    | 80009    | 342-0582-00      |
|                  | 343-1025-00        |                             | 1   |   | RETAINER, XSTR:POLYPHENYLENE                     |   |   |   |                    | 80009    | 343-1025-00      |
|                  | -----              | -----                       | 1   |   | CKT BOARD ASSY:CURRENT LIMIT(SEE A19 REPL)       |   |   |   |                    |          |                  |
|                  | 344-0154-03        |                             | 2   | . | CLIP, ELECTRICAL:FUSE, CKT BD MT                 |   |   |   |                    | 80009    | 344-0154-03      |



| Fig. & Index No. | Tektronix Part No. | Serial/Model No. Eff Dscont | Qty | 1 2 3 4 5 | Name & Description                                                                                   | Mfr Code | Mfr Part Number |
|------------------|--------------------|-----------------------------|-----|-----------|------------------------------------------------------------------------------------------------------|----------|-----------------|
| 2-1              | 334-4251-00        |                             | 1   |           | MARKER, IDENT:MKD CAUTION                                                                            | 80009    | 334-4251-00     |
| -2               | 337-2773-00        |                             | 1   |           | SHIELD, ELEC:POWER SUPPLY, LOWER, PLSTC<br>(ATTACHING PARTS)                                         | 80009    | 337-2773-00     |
| -3               | 211-0304-00        |                             | 1   |           | SCREW, MACHINE:4-40 X 0.312, PNH<br>- - - * - - - -                                                  | 01536    | OBD             |
| -4               | 386-4613-00        |                             | 1   |           | SUPPORT, SHIELD:<br>(ATTACHING PARTS)                                                                | 80009    | 386-4613-00     |
| -5               | 211-0305-00        |                             | 2   |           | SCREW, MACHINE:4-40 X 0.437, PNH<br>- - - * - - - -                                                  | 01536    | OBD             |
| -6               | 334-4251-00        |                             | 1   |           | MARKER, IDENT:MKD CAUTION                                                                            | 80009    | 334-4251-00     |
| -7               | 348-0721-00        |                             | 1   |           | GROMMET, PLASTIC:BLACK POLYSUFONE                                                                    | 80009    | 348-0721-00     |
| -8               | 348-0555-00        |                             | 1   |           | GROMMET, PLASTIC:SIL GY, U SHAPE, 0.52 ID                                                            | 80009    | 348-0555-00     |
| -9               | 344-0334-00        |                             | 1   |           | CLIP, CIRCUIT BD:PLASTIC                                                                             | 80009    | 344-0334-00     |
| -10              | 337-2772-00        |                             | 1   |           | SHIELD, ELEC:POWER SUPPLY, AL<br>(ATTACHING PARTS)                                                   | 80009    | 337-2772-00     |
| -11              | 211-0304-00        | B010100 B012542             | 3   |           | SCREW, MACHINE:4-40 X 0.312, PNH                                                                     | 01536    | OBD             |
|                  | 211-0305-00        | B012543                     | 3   |           | SCREW, MACHINE:4-40 X 0.437, PNH                                                                     | 01536    | OBD             |
| -12              | 211-0303-00        |                             | 2   |           | SCREW, MACHINE:4-40 X 0.25, FLH 100 DEG<br>- - - * - - - -                                           | 01536    | OBD             |
| -13              | 366-1480-03        |                             | 1   |           | PUSH BUTTON:BLACK, OFF                                                                               | 80009    | 366-1480-03     |
| -14              | 384-1576-00        |                             | 1   |           | EXTENSION SHAFT:12.809 L, PLASTIC                                                                    | 80009    | 384-1576-00     |
| -15              | 337-2915-00        |                             | 1   |           | SHIELD, ELEC:ALTERNATE SWEEP<br>(ATTACHING PARTS)                                                    | 80009    | 337-2915-00     |
| -16              | 211-0304-00        |                             | 2   |           | SCREW, MACHINE:4-40 X 0.312, PNH<br>- - - * - - - -                                                  | 01536    | OBD             |
| -17              | 129-0906-00        |                             | 2   |           | SPACER, POST:0.685 L W/4-40 INT & EXT THD<br>(ATTACHING PARTS)                                       | 80009    | 129-0906-00     |
| -18              | 210-0586-00        |                             | 2   |           | NUT, PL, ASSEM WA:4-40 X 0.25, STL CD PL<br>- - - * - - - -                                          | 83385    | OBD             |
| -19              | -----              |                             | 1   |           | CKT BOARD ASSY:ALTERNATE SWEEP(SEE A13 REPL)                                                         |          |                 |
| -20              | 131-0589-00        |                             | 27  |           | . TERMINAL, PIN:0.46 L X 0.025 SQ                                                                    | 80009    | 131-0589-00     |
| -21              | -----              |                             | 1   |           | CKT BOARD ASSY:MAIN(SEE A10 REPL)<br>(ATTACHING PARTS)                                               |          |                 |
| -22              | 213-0882-00        |                             | 3   |           | SCREW, TAPPING:6-32 X 0.437 TYPE C                                                                   | 01536    | OBD             |
| -23              | 211-0302-00        |                             | 2   |           | SCREW, MACHINE:4-40 X 0.75, PNH<br>- - - * - - - -                                                   | 01536    | OBD             |
| -24              | -----              |                             | -   |           | CKT BOARD ASSY INCLUDES:<br>3 . TERMINAL, PIN:(SEE A10P1011, P2011, P6001,<br>- . P7001, P7055 REPL) |          |                 |
| -25              | -----              |                             | 1   |           | . RES, VAR, NONWIR:(SEE A10R883 REPL)<br>(ATTACHING PARTS)                                           |          |                 |
| -26              | 220-0495-00        |                             | 1   |           | . NUT, PLAIN, HEX. :0.375-32 X 0.438 INCH BRS<br>- - - * - - - -                                     | 73743    | OBD             |
| -27              | 337-2945-00        |                             | 1   |           | . SHIELD, ELEC:POTENTIOMETER                                                                         | 80009    | 337-2945-00     |
| -28              | 361-1047-00        |                             | 1   |           | . SPACER, VAR RES:0.3 X 0.615 X 0.55                                                                 | 80009    | 361-1047-00     |
| -29              | 214-0498-00        |                             | 2   |           | . HEAT SINK, XSTR:TO-18, AL BLACK ANODIZED                                                           | 05820    | 201-AB          |
| -30              | 337-2922-00        |                             | 1   |           | . SHIELD, ELEC:HORIZONTAL AMPLIFIER                                                                  | 80009    | 337-2922-00     |
| -31              | 200-2735-00        |                             | 1   |           | . COVER, POWER SW:                                                                                   | 80009    | 200-2735-00     |
| -32              | -----              |                             | 1   |           | . SWITCH, PUSH:(SEE A10S901 REPL)                                                                    |          |                 |
| -33              | 343-0088-00        |                             | 1   |           | . CLAMP, LOOP:0.062 INCH DIA                                                                         | 80009    | 343-0088-00     |
| -34              | 131-1048-00        |                             | 4   |           | . TERM.QIK DISC:CKT BD MT, 0.11 X 0.02                                                               | 00779    | 61134-1         |
| -35              | -----              |                             | 1   |           | . SEMICOND DEVICE:(SEE A10U990 REPL)                                                                 |          |                 |
| -36              | -----              |                             | 1   |           | . THYRISTOR:(SEE A10Q925 REPL)<br>(ATTACHING PARTS)                                                  |          |                 |
| -37              | 211-0304-00        |                             | 1   |           | . SCREW, MACHINE:4-40 X 0.312, PNH                                                                   | 01536    | OBD             |
| -38              | 210-0406-00        |                             | 1   |           | . NUT, PLAIN, HEX. :4-40 X 0.188 INCH, BRS<br>- - - * - - - -                                        | 73743    | 2X12161-402     |
| -39              | -----              |                             | 9   |           | . TERM, TEST POINT:(SEE A10TP500, TP501, TP915,<br>- . TP920, TP934, TP940, TP951, TP952 REPL)       |          |                 |
| -40              | 343-0969-00        |                             | 1   |           | . RETAINER, XSTR:POLYPHENYLENESULFIDE<br>(ATTACHING PARTS)                                           | 80009    | 343-0969-00     |
| -41              | 211-0691-00        |                             | 1   |           | . SCREW, MACHINE:6-32 X 0.625, PNH                                                                   | 01536    | OBD             |
| -42              | 210-0457-00        |                             | 1   |           | . NUT, PL, ASSEM WA:6-32 X 0.312 INCH, STL<br>- - - * - - - -                                        | 83385    | OBD             |
| -43              | -----              |                             | 2   |           | . TRANSISTOR:(SEE A10Q940, Q942 REPL)<br>(ATTACHING PARTS)                                           |          |                 |
| -44              | 342-0555-00        |                             | 1   |           | . INSULATOR, PLATE:HEAT SINK, AL<br>- - - * - - - -                                                  | 80009    | 342-0555-00     |

**Replaceable Mechanical Parts—2215 Service**

| Fig. & Index No. | Tektronix Part No. | Serial/Model No Eff | Dscont  | Qty | 1 2 3 4 5 | Name & Description                                            | Mfr Code | Mfr Part Number  |
|------------------|--------------------|---------------------|---------|-----|-----------|---------------------------------------------------------------|----------|------------------|
| 2-45             | -----              |                     |         | 1   | .         | MICROCIRCUIT,:(SEE A10U985 REPL)<br>(ATTACHING PARTS)         |          |                  |
| -46              | 211-0304-00        |                     |         | 1   | .         | SCREW,MACHINE:4-40 X 0.312,PNH                                | 01536    | OBD              |
| -47              | 210-0586-00        |                     |         | 1   | .         | NUT,PL,ASSEM WA:4-40 X 0.25,STL CD PL<br>-----*-----          | 83385    | OBD              |
| -48              | 407-2729-00        |                     |         | 1   | .         | BRACKET,HEAT SK:AL<br>(ATTACHING PARTS)                       | 80009    | 407-2729-00      |
| -49              | 211-0303-00        |                     |         | 2   | .         | SCREW,MACHINE:4-40 X 0.25,FLH 100 DEG<br>-----*-----          | 01536    | OBD              |
| -50              | 214-0973-00        |                     |         | 1   | .         | HEAT SINK,ELEC:0.28 X 0.18 OVAL X 0.187"H                     | 80009    | 214-0973-00      |
| -51              | 214-1061-05        |                     |         | 1   |           | SPRING,GROUND:PLATED                                          | 80009    | 214-1061-05      |
| -52              | 200-2519-00        |                     |         | 1   |           | CAP.,CRT SOCKET:NATURAL LEXAN                                 | 80009    | 200-2519-00      |
| -53              | -----              |                     |         | 1   |           | DELAY LINE,ELEC:(SEE DL350 REPL)<br>(ATTACHING PARTS)         |          |                  |
| -54              | 213-0882-00        |                     |         | 2   |           | SCREW,TAPPING:6-32 X 0.437 TYPE C<br>-----*-----              | 01536    | OBD              |
| -55              | 426-1766-00        |                     |         | 1   |           | MOUNT,RESILIENT:CRT,REAR                                      | 80009    | 426-1766-00      |
| -56              | 136-0202-04        |                     |         | 1   |           | SKT,PL-IN ELEK:ELECTRON TUBE,14 CONT                          | 80009    | 136-0202-04      |
| -57              | 334-1379-00        |                     |         | 1   |           | LABEL:CRT,ADHESIVE BACK                                       | 80009    | 334-1379-00      |
| -58              | 334-1951-00        |                     |         | 1   |           | MARKER,IDENT:CRT WARNING                                      | 80009    | 334-1951-00      |
| -59              | 337-2774-00        |                     |         | 1   |           | SHIELD,ELEC:CRT,STEEL                                         | 80009    | 337-2774-00      |
| -60              | 386-4443-00        |                     |         | 1   |           | SUPPORT,SHIELD:CRT,FRONT,PLASTIC                              | 80009    | 386-4443-00      |
| -61              | -----              |                     |         | 1   |           | ELECTRON TUBE:(SEE V870 REPL)                                 |          |                  |
| -62              | 134-0158-00        |                     |         | 2   |           | BUTTON,PLUG:0.187 DIA,NYLON                                   | 02768    | 207-080501-00    |
| -63              | 334-3379-02        |                     |         | 1   |           | MARKER,IDENT:MARKED GROUND SYMBOL                             | 80009    | 334-3379-02      |
| -64              | -----              |                     |         | 1   |           | CONN,RCPT,ELEC:(SEE J8001 REPL)                               |          |                  |
| -65              | 200-2264-00        |                     |         | 1   |           | CAP.,FUSEHOLDER:3AG FUSES                                     | S3629    | FEK 031 1666     |
| -66              | 200-1388-03        |                     |         | 1   |           | COVER,FUSE,LEAD:POLYURETHANE                                  | 80009    | 200-1388-03      |
| -67              | 204-0833-00        |                     |         | 1   |           | BODY,FUSEHOLDER:3AG & 5 X 20MM FUSES                          | S3629    | 031.1653(MDLFEU) |
| -68              | 210-1039-00        |                     |         | 1   |           | WASHER,LOCK:INT,0.521 ID X 0.625 INCH OD                      | 24931    | OBD              |
| -69              | 210-0202-00        |                     |         | 1   |           | TERMINAL,LUG:0.146 ID,LOCKING,BRZ TINNED<br>(ATTACHING PARTS) | 78189    | 2104-06-00-2520N |
| -70              | 210-0457-00        |                     |         | 1   |           | NUT,PL,ASSEM WA:6-32 X 0.312 INCH,STL<br>-----*-----          | 83385    | OBD              |
| -71              | 348-0738-00        |                     |         | 1   |           | GROMMET,PLASTIC:0.312 ID,NYLON,BLACK                          | 28520    | SB-437-5         |
| -72              | 337-2947-00        |                     |         | 1   |           | SHIELD,ELEC:INDUCTOR<br>(ATTACHING PARTS)                     | 80009    | 337-2947-00      |
| -73              | 211-0303-00        |                     |         | 2   |           | SCREW,MACHINE:4-40 X 0.25,FLH 100 DEG<br>-----*-----          | 01536    | OBD              |
| -74              | -----              |                     |         | 1   |           | COIL,RF:(SEE L925 REPL)                                       |          |                  |
| -75              | 161-0033-26        |                     |         | 1   |           | CABLE ASSY,PWR:3,18 AWG,125V,101.3 L                          | 16428    | KH-9230          |
| -76              | 358-0161-00        | B010100             | B011399 | 1   |           | BSHG,STRAIN RLF:FOR 0.50 INCH HOLE,PLASTIC                    | 28520    | 1147 SR-5P-4     |
|                  | 358-0161-01        | B011400             |         | 1   |           | BSHG,STRAIN RLF:FOR 0.29 INCH DIA CABLE                       | 28520    | 1154 SR-5L-1     |
|                  | 348-0746-00        | XB011400            |         | 1   |           | CUSHION,IDCTR:MOLDED POLYURETHANE                             | 80009    | 348-0746-00      |
|                  | 211-0303-00        | XB011400            |         | 1   |           | SCREW,MACHINE:4-40 X 0.25,FLH 100 DEG                         | 01536    | OBD              |
|                  | 210-0586-00        | XB011400            |         | 1   |           | NUT,PL,ASSEM WA:4-40 X 0.25,STL CD PL                         | 83385    | OBD              |
| -77              | 200-2531-00        |                     |         | 1   |           | COVER,POWER:PLASTIC                                           | 80009    | 200-2531-00      |
| -78              | 441-1536-00        |                     |         | 1   |           | CHASSIS,SCOPE:REAR MAIN<br>(ATTACHING PARTS)                  | 80009    | 441-1536-00      |
| -79              | 213-0881-00        |                     |         | 2   |           | SCREW,TAPPING:6-32 X 0.25 TYPE C<br>-----*-----               | 01536    | OBD              |

| Fig. & Index No. | Tektronix Part No. | Serial/Model No. Eff | Dscont | Qty | 1 | 2 | 3 | 4 | 5 | Name & Description                     | Mfr Code | Mfr Part Number |
|------------------|--------------------|----------------------|--------|-----|---|---|---|---|---|----------------------------------------|----------|-----------------|
| WIRE ASSEMBLIES  |                    |                      |        |     |   |   |   |   |   |                                        |          |                 |
| 175-3092-00      | B010100            | B010417              |        | 1   |   |   |   |   |   | CA ASSY,SP,ELEC:4,26 AWG,3.0 L,RIBBON  | 80009    | 175-3092-00     |
| 175-4662-00      | B010418            |                      |        | 1   |   |   |   |   |   | CA ASSY,SP,ELEC:4,22 AWG,3.5 L,RIBBON  | 80009    | 175-4662-00     |
| -----            |                    |                      |        |     |   |   |   |   |   | (FROM A10 TO A12P1100)                 |          |                 |
| 352-0162-02      |                    |                      |        | 2   |   |   |   |   |   | . CONN BODY,PL,EL:4 WIRE RED           | 80009    | 352-0162-02     |
| 175-3616-00      | B010100            | B010417              |        | 1   |   |   |   |   |   | CA ASSY,SP,ELEC:4,26 AWG,5.0 L,RIBBON  | 80009    | 175-3616-00     |
| 175-4663-00      | B010418            |                      |        | 1   |   |   |   |   |   | CA ASSY,SP,ELEC:4,22 AWG,5.5 L,RIBBON  | 80009    | 175-4663-00     |
| -----            |                    |                      |        |     |   |   |   |   |   | (FROM A10 TO A12P2100)                 |          |                 |
| 352-0162-00      |                    |                      |        | 2   |   |   |   |   |   | . HLDR,TERM CONN:4 WIRE BLACK          | 80009    | 352-0162-00     |
| 175-3617-00      | B010100            | B010417              |        | 1   |   |   |   |   |   | CA ASSY,SP,ELEC:7,26 AWG,5.5 L,RIBBON  | 80009    | 175-3617-00     |
| 175-4664-00      | B010418            |                      |        | 1   |   |   |   |   |   | CA ASSY,SP,ELEC:7,22 AWG,4.0 L,RIBBON  | 80009    | 175-4664-00     |
| -----            |                    |                      |        |     |   |   |   |   |   | (FROM A10P7001 TO A12P7000)            |          |                 |
| 352-0165-00      |                    |                      |        | 1   |   |   |   |   |   | . CONN BODY,PL,EL:7 WIRE BLACK         | 80009    | 352-0165-00     |
| 175-3869-00      | B010100            | B010417              |        | 1   |   |   |   |   |   | CA ASSY,SP,ELEC:10,26 AWG,8.0L,RIBBON  | 80009    | 175-3869-00     |
| 175-4665-00      | B010418            |                      |        | 1   |   |   |   |   |   | CA ASSY,SP,ELEC:10,22 AWG,7.0 L,RIBBON | 80009    | 175-4665-00     |
| -----            |                    |                      |        |     |   |   |   |   |   | (FROM A10P6001 TO A12P6000)            |          |                 |
| 352-0168-00      |                    |                      |        | 2   |   |   |   |   |   | . CONN BODY,PL,EL:10 WIRE BLACK        | 80009    | 352-0168-00     |
| 175-4466-00      |                    |                      |        | 1   |   |   |   |   |   | CABLE ASSY,RF:50 OHM COAX,4.0 L,9-1    | 80009    | 175-4466-00     |
| 352-0169-00      |                    |                      |        | 1   |   |   |   |   |   | . HLDR,TERM CONN:2 WIRE BLACK          | 80009    | 352-0169-00     |
| 175-3615-00      |                    |                      |        | 1   |   |   |   |   |   | CA ASSY,SP,ELEC:3,26 AWG,9.0 L,RIBBON  | 80009    | 175-3615-00     |
| -----            |                    |                      |        |     |   |   |   |   |   | (FROM A10P7005 TO DL350)               |          |                 |
| 352-0161-00      |                    |                      |        | 1   |   |   |   |   |   | . HLDR,TERM CONN:3 WIRE BLACK          | 80009    | 352-0161-00     |
| 175-4232-00      |                    |                      |        | 1   |   |   |   |   |   | CA ASSY,SP,ELEC:2,26 AWG,4.0 L,RIBBON  | 80009    | 175-4232-00     |
| -----            |                    |                      |        |     |   |   |   |   |   | (FROM A11 TO R647)                     |          |                 |

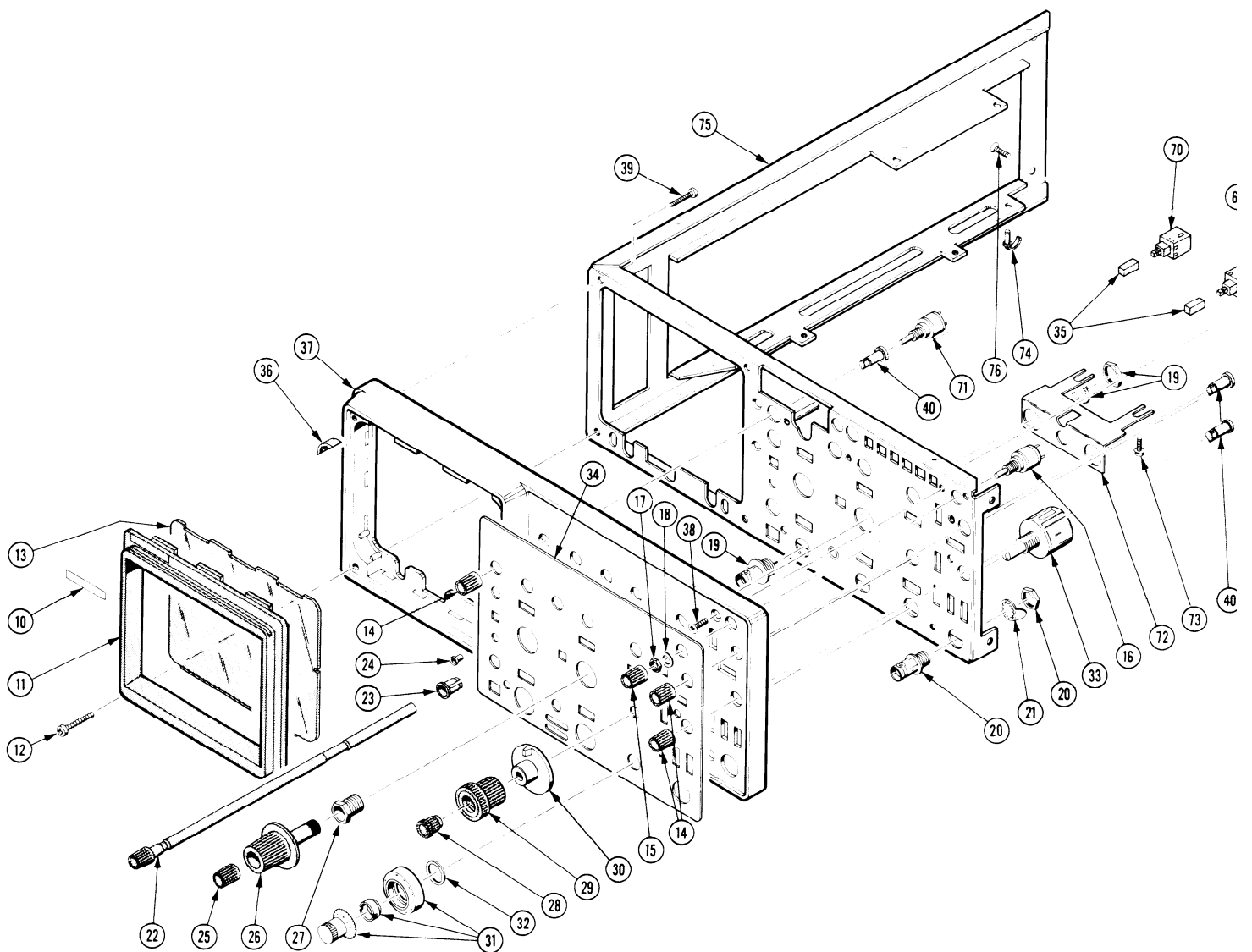

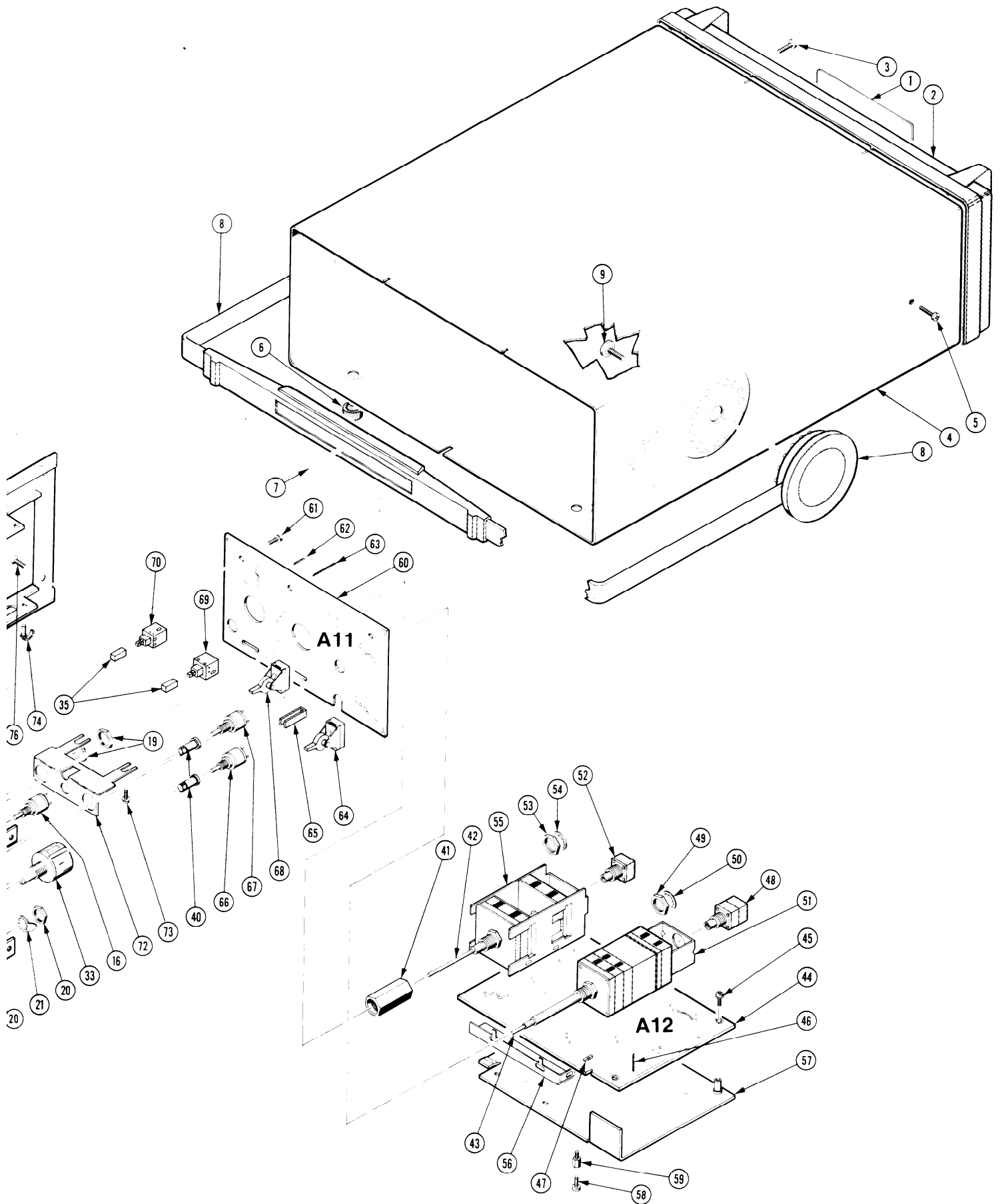

@

2215 OSCILLOSCOPE

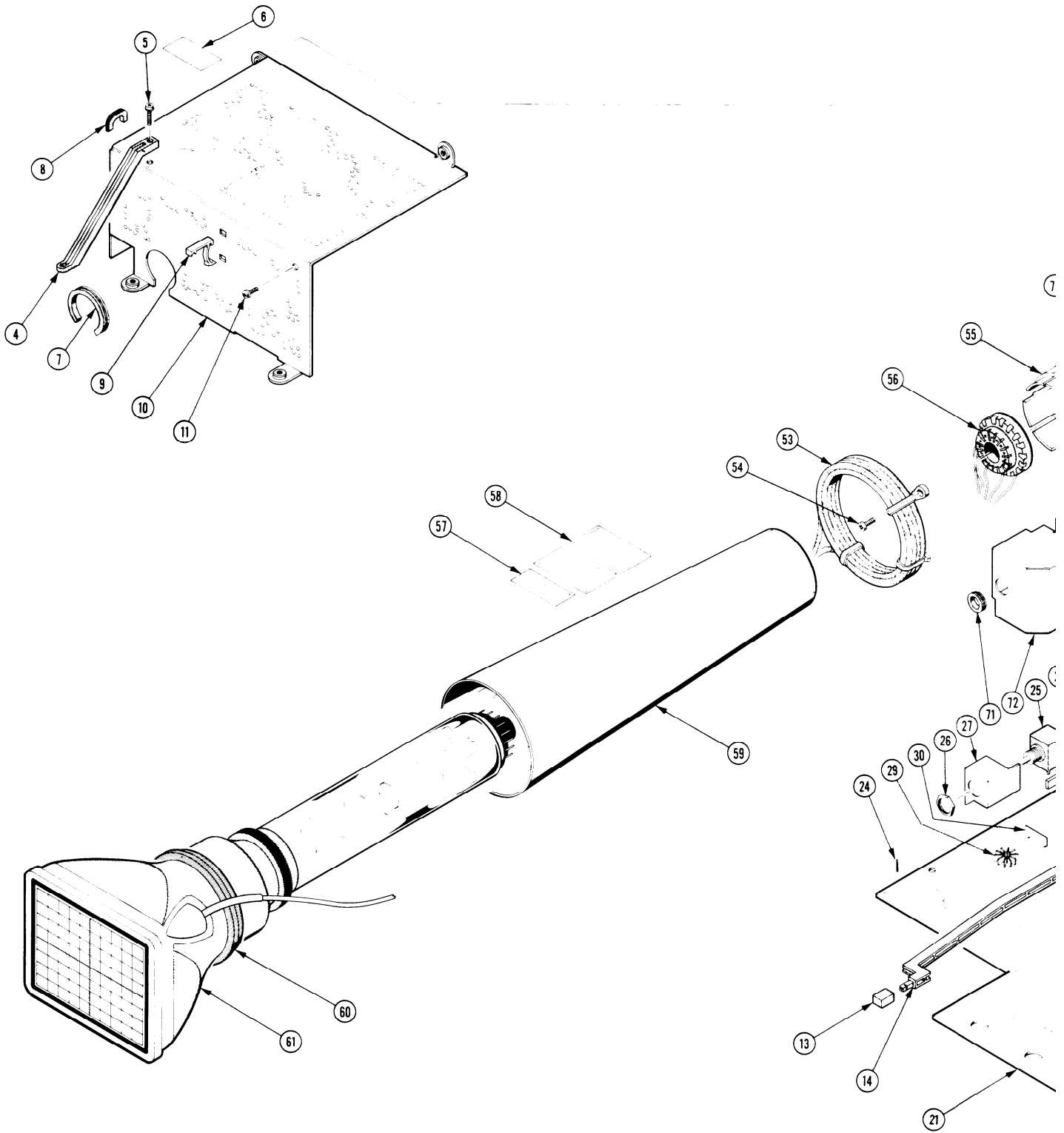

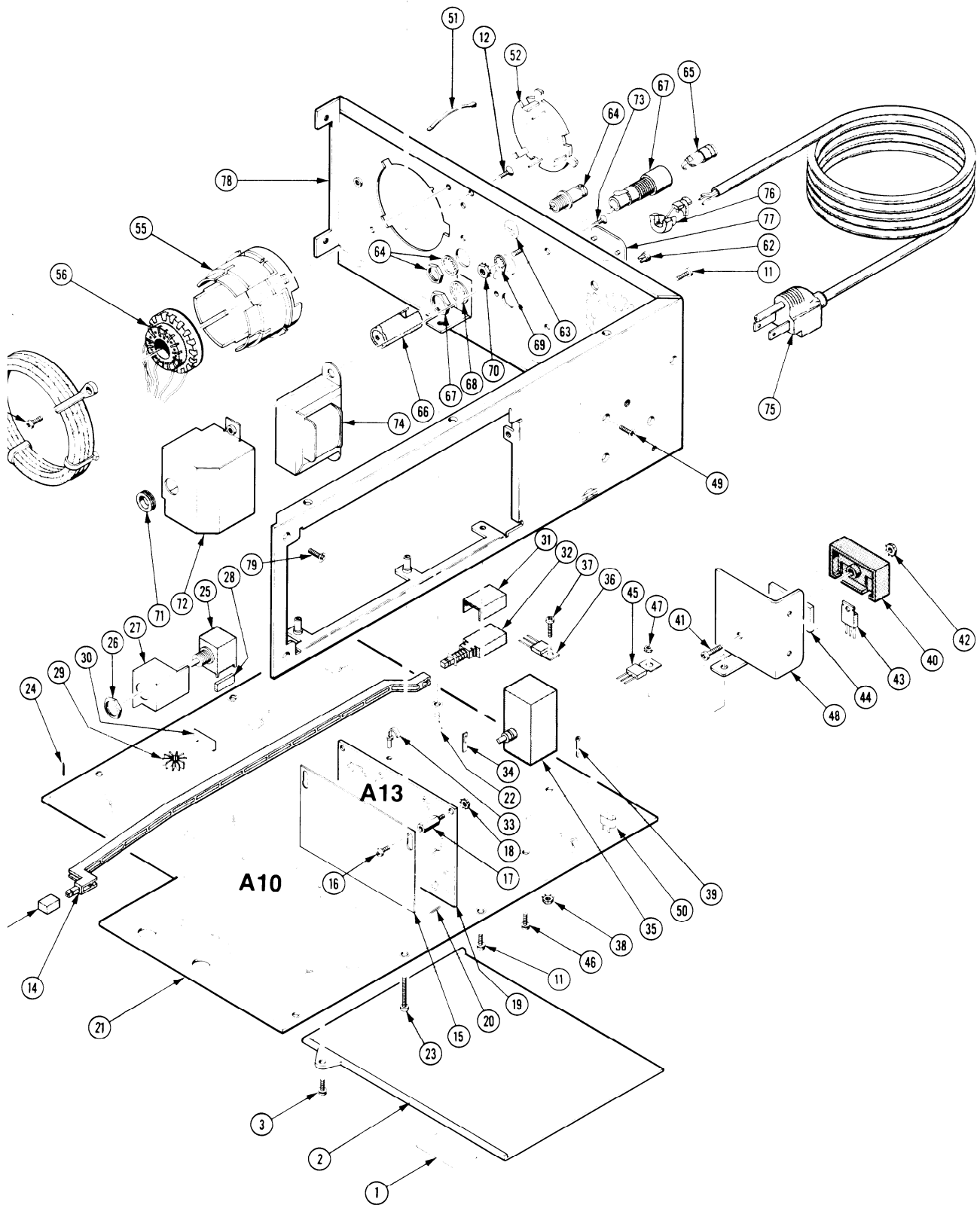

@

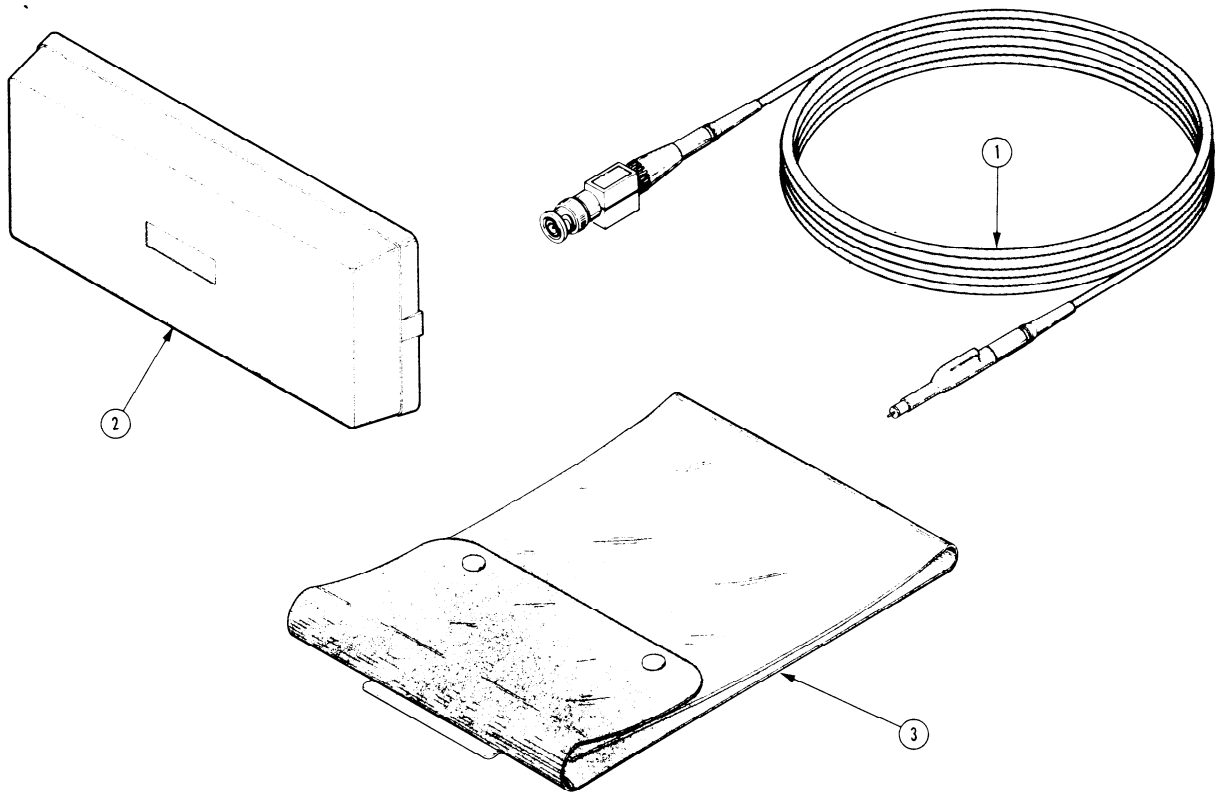

| Fig. & Index No.     | Tektronix Part No. | Serial/Model No. Eff | Dscont | Qty | 1 | 2 | 3 | 4 | 5 | Name & Description                          | Mfr Code | Mfr Part Number |
|----------------------|--------------------|----------------------|--------|-----|---|---|---|---|---|---------------------------------------------|----------|-----------------|
| ACCESSORIES          |                    |                      |        |     |   |   |   |   |   |                                             |          |                 |
| -1                   | 010-6120-01        |                      |        | 2   |   |   |   |   |   | PROBE,VOLTAGE:P6120,1.5M L,10 X W/ACCESS    | 80009    | 010-6120-01     |
|                      | 013-0191-00        |                      |        | 2   |   |   |   |   |   | TIP PROBE:W/ACTUATOR                        | 80009    | 013-0191-00     |
|                      | 070-3398-00        |                      |        | 1   |   |   |   |   |   | MANUAL,TECH:OPERATORS,2215                  | 80009    | 070-3398-00     |
|                      | 070-3826-00        |                      |        | 1   |   |   |   |   |   | MANUAL,TECH:SERVICE,2215                    | 80009    | 070-3826-00     |
|                      | 159-0021-00        |                      |        | 1   |   |   |   |   |   | FUSE,CARTRIDGE:3AG,2A,250V,FAST-BLOW        | 71400    | AGC 2           |
| OPTIONAL ACCESSORIES |                    |                      |        |     |   |   |   |   |   |                                             |          |                 |
|                      | 020-0672-00        |                      |        | 1   |   |   |   |   |   | ACCESSORY KIT:                              | 80009    | 020-0672-00     |
| -2                   | 200-2520-00        |                      |        | 1   |   |   |   |   |   | . COVER,SCOPE:FRONT,ABS                     | 80009    | 200-2520-00     |
| -3                   | 016-0677-00        |                      |        | 1   |   |   |   |   |   | . POUCH,ACCESSORY:                          | 80009    | 016-0677-00     |
|                      | 386-4674-00        |                      |        | 1   |   |   |   |   |   | . . PLATE,MOUNTING:ACCESSORY POUCH          | 80009    | 386-4674-00     |
|                      | 386-2370-00        |                      |        | 2   |   |   |   |   |   | . . PLATE,REINF:ACCESSORY POUCH             | 80009    | 386-2370-00     |
|                      | 212-0068-00        |                      |        | 4   |   |   |   |   |   | . . SCREW,MACHINE:8-32 X 0.312 INCH,TRH STL | 77250    | OBD             |
|                      | 220-0736-00        |                      |        | 4   |   |   |   |   |   | . . NUT,PL,EXT WSHR:8-32 X 0.344 HEX,NYLON  | 23050    | OBD             |



## **MANUAL CHANGE INFORMATION**

At Tektronix, we continually strive to keep up with latest electronic developments by adding circuit and component improvements to our instruments as soon as they are developed and tested.

Sometimes, due to printing and shipping requirements, we can't get these changes immediately into printed manuals. Hence, your manual may contain new change information on following pages.

A single change may affect several sections. Since the change information sheets are carried in the manual until all changes are permanently entered, some duplication may occur. If no such change pages appear following this page, your manual is correct as printed.

Date: 10-1-81 Change Reference: C8/1081

Product: 2215 OSCILLOSCOPE SERVICE Manual Part No.: 070-3826-00

DESCRIPTION

EFF SN B010436-UP

Pilot Change #27

REPLACEABLE ELECTRICAL PARTS AND SCHEMATIC CHANGES

CHANGE TO:

|          |             |                                       |
|----------|-------------|---------------------------------------|
| A19R935  | 321-0140-00 | RES., FXD, FILM: 280 OHM, 1%, 0.125W  |
| A19R936  | 321-0152-00 | RES., FXD, FILM: 374 OHM, 1%, 0.125W  |
| A19R937  | 308-0843-00 | RES., FXD, WW: 0.2 OHM, 5%, 1W        |
| A19VR933 | 152-0286-00 | SEMICOND DEVIZE: ZENER, 0.4W, 75V, 5% |

DIAGRAM 9 A19 CURRENT LIMIT BOARD

CHANGE:

R935 (location 2F) to a 280  $\Omega$  resistor.  
R936 (location 2F) to a 374  $\Omega$  resistor.  
R937 (location 2F) to a 0.2  $\Omega$  resistor.  
VR933 (location 2F) to a 75 V zener.

**DESCRIPTION**

EFF ALL SN UNLESS NOTED OTHERWISE

TEXT CHANGES

Page 2-3 Callout 4 PROBE ADJUST

CHANGE TO READ: ... 0.5 V, negative-going, square-wave voltage ...

REPLACEABLE ELECTRICAL PARTS LIST CHANGES

CHANGE TO:

|                      |             | <u>SN</u> |                                                                                    | <u>REF</u> |
|----------------------|-------------|-----------|------------------------------------------------------------------------------------|------------|
| A10C604              | 281-0775-00 |           | CAP., FXD, CER DI:0.1UF, 20%, 50V                                                  | PC 32      |
| A10VR483             | 152-0662-00 |           | SEMICOND DEVICE:ZENER, 400MW, 5V, 1%                                               | PC 12      |
| A12C628A,<br>B, C, D | 295-0194-00 |           | CAP, SET, MATCHED: 2 EA 1.0UF, 1.5%, 50V<br>2 EA 0.01UF, 1.5%, 100V,<br>MTCH 0.75% |            |
| A13VR584             | 152-0662-00 | B012543   | SEMICOND DEVICE:ZENER, 400MW, 5V, 1%                                               | PC 34      |

ADD:

|          |             |         |                                                     |       |
|----------|-------------|---------|-----------------------------------------------------|-------|
| A10C601  | 281-0774-00 |         | CAP., FXD, CER DI:0.022UF, 20%, 100V                | PC 32 |
| A10R854  | 315-0180-00 | B012543 | RES., FXD, CMPSN:18 OHM, 5%, 0.25W                  | PC 33 |
| A11C265  | 281-0773-00 |         | CAP., FXD, CER DI:0.01UF, 10%, 100V                 | PC 13 |
| A12C140  | 281-0775-00 |         | CAP., FXD, CER DI:0.1UF, 20%, 50V                   |       |
| A12P2000 | 136-0328-02 |         | SOCKET, PIN TERM:U/W 0.025 SQ PINS<br>(QUANTITY 10) |       |
| A19Q938  | 151-1141-00 |         | TRANSISTOR:FE, N-CHANNEL, SI, IRF 730<br>TO-220     | PC 9  |

REMOVE:

|         |                         |         |                                        |  |
|---------|-------------------------|---------|----------------------------------------|--|
| A10C140 | 281-0775-00             |         | CAP., FXD, CER DI:0.1UF, 20%, 50V      |  |
| A10C314 | 281-0773-00             |         | CAP., FXD, CER DI:0.01UF, 10%, 100V    |  |
| A10R614 | 315-0512-00 (2nd entry) |         | RES., FXD, CMPSN:5.1K OHM, 5%, 0.25W   |  |
| A10W854 | 131-0566-00 (1st entry) |         | BUS, CONDUCTOR:DUMMY RES, 2.375, 22AWG |  |
| A10W854 | 131-0566-00 (2nd entry) | B012543 | BUS, CONDUCTOR:DUMMY RES, 2.375, 22AWG |  |
| A12C377 | 283-0181-00             |         | CAP., FXD, CER DI:1.8PF, 10%, 100V     |  |
| A12C387 | 283-0181-00             |         | CAP., FXD, CER DI:1.8PF, 10%, 100V     |  |

DESCRIPTION

Below are circuit number changes but do not affect the Part Numbers or Descriptions.

|                |          |    |          |             |       |
|----------------|----------|----|----------|-------------|-------|
| CHANGE:        | A10MV901 | TO | A10VR901 | 307-0456-00 |       |
| (1st entry)    | A11C101  | TO | A11C102  | 285-0515-00 |       |
|                | A11J2001 | TO | A11J2000 | 131-0787-00 |       |
|                | A12C641  | TO | A12C632  | 283-0158-00 | PC 41 |
|                | A12P6001 | TO | A12P6000 | 131-0608-00 |       |
|                | A12R694  | TO | A12R632  | 315-0114-00 | PC 41 |
|                | A13R642  | TO | A13R641  | 315-0102-00 | PC 41 |
|                | A13R646  | TO | A13R652  | 315-0162-00 | PC 41 |
|                | A13R658  | TO | A13R657  | 315-0473-00 | PC 41 |
| (chassis part) | F9001    | TO | F901     | 159-0021-00 |       |

DIAGRAM CHANGES

DIAGRAM 5 SWEEP GENERATOR & LOGIC

|         |                    |    |      |  |       |
|---------|--------------------|----|------|--|-------|
| CHANGE: | C641 (location 3K) | TO | C632 |  | PC 41 |
|         | R694 (location 3K) | TO | R632 |  | PC 41 |

DIAGRAM 10 ALTERNATE B SWEEP

|         |                    |    |      |  |       |
|---------|--------------------|----|------|--|-------|
| CHANGE: | R642 (location 4E) | TO | R641 |  | PC 41 |
|         | R646 (location 4F) | TO | R652 |  | PC 41 |
|         | R658 (location 4G) | TO | R657 |  | PC 41 |